



Service Bulletin



SPECIAL COVERAGE

SUBJECT: Special Coverage Adjustment – Driver Door Switch Short Circuit

**MODELS: 2006-2007 Buick Rainier
2006 Chevrolet TrailBlazer EXT
2006-2007 Chevrolet TrailBlazer
2006 GMC Envoy XL
2006-2007 GMC Envoy**

CONDITION

On some 2006 model year Chevrolet TrailBlazer EXT and GMC Envoy XL; and 2006-2007 model year Buick Rainier, Chevrolet TrailBlazer, and GMC Envoy vehicles, if fluid enters the driver's door module, it may cause a short in the circuit board. A short may cause the power door lock and power window switches to function intermittently or become inoperative. In extremely rare cases, a short may cause overheating, which could melt components of the door module, producing odor, smoke, or flame.

SPECIAL COVERAGE ADJUSTMENT

If a vehicle involved in this Special Coverage demonstrates the condition or symptoms described above, dealers are to replace the driver door module, regardless of the vehicle's age or mileage.

For vehicles covered by Vehicle Service Contracts, all eligible claims with repair orders on or after January 16, 2013, are covered by this special coverage and must be submitted using the labor operation codes provided with this bulletin. Claims with repair orders prior to January 16, 2013 must be submitted to the Service Contract provider.

VEHICLES INVOLVED

All involved vehicles are identified by Vehicle Identification Number on the Applicable Warranties section in GM Global Warranty Management system. Dealership service personnel should always check this site to confirm vehicle involvement prior to beginning any required inspections and/or repairs. It is important to routinely use this tool to verify eligibility because not all similar vehicles may be involved regardless of description or option content.

PART INFORMATION

Parts required to complete this special coverage are to be obtained from General Motors Customer Care and Aftersales (GMCC&A).

Part Number	Description	Quantity/ Vehicle
Export - Chevrolet		
25861573	SWITCH, DR LK & SI WDO (CASHMERE) (Heated Seats)	1
25861577	SWITCH, DR LK & SI WDO (CASHMERE)	1
25867006	SWITCH, DR LK & SI WDO (EBONY) (Heated Seats)	1
25867002	SWITCH, DR LK & SI WDO (EBONY)	1
25866999	SWITCH, DR LK & SI WDO (GRAY) (Heated Seats)	1
25867003	SWITCH, DR LK & SI WDO (GRAY)	1

Chevrolet		
25861584	SWITCH, DR LK & SI WDO (CASHMERE) (Heated Seats)	1
25861580	SWITCH, DR LK & SI WDO (CASHMERE)	1
25867000	SWITCH, DR LK & SI WDO (EBONY) (Heated Seats)	1
25867004	SWITCH, DR LK & SI WDO (EBONY)	1
25867001	SWITCH, DR LK & SI WDO (GRAY) (Heated Seats)	1
25867005	SWITCH, DR LK & SI WDO (GRAY)	1

GMC		
25866992	SWITCH, DR LK & SI WDO (EBONY) (heated seat & driver memory pkg)	1
25866997	SWITCH, DR LK & SI WDO (EBONY) (driver memory pkg – no heated seats)	1
25866993	SWITCH, DR LK & SI WDO (EBONY) (no heated seats or driver memory pkg)	1
25866996	SWITCH, DR LK & SI WDO (GRAY) (heated seats & driver memory pkg)	1
25866998	SWITCH, DR LK & SI WDO (GRAY) (driver memory pkg – no heated seats)	1
25866994	SWITCH, DR LK & SI WDO (GRAY) (no heated seats or driver memory pkg)	1

Buick		
25861557	SWITCH, DR LK & SI WDO (CASHMERE) (heated seats)	1
25861561	SWITCH, DR LK & SI WDO (DK CASHMERE) (no heated seats)	1
25861556	SWITCH, DR LK & SI WDO (GRAY) (heated seats)	1
25861560	SWITCH, DR LK & SI WDO (GRAY) (no heated seats)	1

SERVICE PROCEDURE

1. Determine if the driver side door lock and side window switch requires replacement using diagnostic information in SI.
 - If the driver side door lock and side window switch requires replacement, proceed to Step 2.
 - If the driver side door lock and side window switch does NOT need to be replaced, determine cause of vehicle condition. Additional diagnostic time and repairs are NOT covered under this field action bulletin. Assign payment through warranty, goodwill or customer pay.

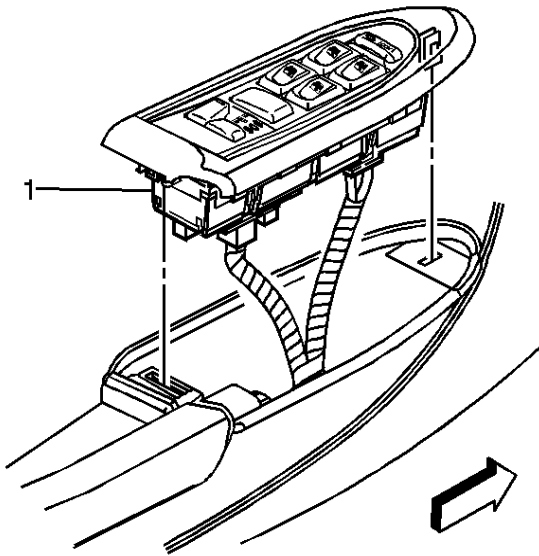

690976

2. Remove the driver side door lock and side window switch. Refer to *Door Lock and Side Window Switch Replacement - Driver Side* in SI.
3. Install a new driver side door lock and side window switch. Refer to *Door Lock and Side Window Switch Replacement - Driver Side* in SI.

CUSTOMER REIMBURSEMENT - For US

Customer requests for reimbursement of previously paid repairs to correct the condition described in this bulletin are to be submitted to the dealer by January 31, 2014, unless otherwise specified by state law. If this is not convenient for the customer, they may mail the completed Customer Reimbursement Request Form and all required documents to the GM Customer Assistance Center. Repairs must have occurred prior to February 8, 2013.

All reasonable and customary costs to correct the condition described in this bulletin should be considered for reimbursement. Any questions or concerns should be reviewed with your District Service Manager – Aftersales prior to processing the request.

When a customer requests reimbursement, they must provide the following:

- A completed Customer Reimbursement Request Form. This form is mailed to the customer or can be obtained through GM GlobalConnect.
- The name and address of the person who paid for the repair.
- Paid receipt confirming the amount of the repair expense, a description of the repair, and the person or entity performing the repair.

IMPORTANT: GM requires dealers to approve or deny a reimbursement request within 30 days of receipt. If a reimbursement request is approved, the dealer should immediately issue a check to the customer and submit an appropriate warranty transaction for the incurred expense. If a reimbursement request is denied, the dealer MUST provide the customer with a clear and concise explanation, in writing, as to why the request was denied. The bottom portion of the Customer Reimbursement Request Form may be used for this purpose. If the denial was due to missing documents, the customer can resubmit the request when the missing documents are obtained, as long as it is still within the allowed reimbursement period.

Warranty transactions for customer reimbursement of previously paid repairs are to be submitted as required by GM Global Warranty Management. Additional information can also be found in Warranty Administration Bulletin 11-00-89-004.

CUSTOMER REIMBURSEMENT - For Canada and Export

Customer requests for reimbursement of previously paid repairs to correct the condition described in this bulletin are to be submitted to the dealer prior to or by January 31, 2014. Repairs must have occurred prior to February 8, 2013.

When a customer requests reimbursement, they must provide the following:

- Proof of ownership at time of repair.
- Original paid receipt confirming the amount of unreimbursed repair expense(s) (including Service Contract deductibles), a description of the repair, and the person or entity performing the repair.

All reasonable and customary costs to correct the condition described in this bulletin should be considered for reimbursement. Any questions or concerns should be reviewed with your GM representative prior to processing the request.

WARRANTY TRANSACTION INFORMATION

Submit a transaction using the table below.

Labor Code	Description	Labor Time
T5879	Diagnostic Time Only – No Repair Required	0.1-0.3
T5880	Door Lock & Side Window Switch Replacement (inc. programming)	0.5
	Add: Diagnostic Time	0.1-0.3
T5881	Customer Reimbursement Approved	0.2
T5882	Customer Reimbursement Denied - For US dealers only	0.1

CUSTOMER NOTIFICATION

General Motors will notify customers of this special coverage on their vehicles (see copy of typical customer letter included with this bulletin - actual divisional letter may vary slightly).



January 2013

Dear General Motors Customer:

As the owner of a General Motors vehicle, your satisfaction with our product is very important to us.

This letter is intended to make you aware that if fluid enters the driver's door module on your 2006 model year Chevrolet TrailBlazer EXT or GMC Envoy XL; or 2006-2007 model year Buick Rainier, Chevrolet TrailBlazer, or GMC Envoy vehicle, it may cause a short in the circuit board. A short may cause the power door lock and power window switches to function intermittently or become inoperative. In extremely rare cases, a short may cause overheating, which could melt components of the door module, producing odor, smoke, or flame.

The symptoms of this condition are:

- Switches may function uncommanded, intermittently or become inoperative.
- You may notice an odor or overheated/hot switches.

What We Are Doing: We are conducting two programs to address this issue. The first program is a safety recall of these vehicles in certain states. A safety recall is being conducted in these areas because we have determined that states using road salt and other chemicals for ice/snow control are much more likely to experience a short circuit in the switch.

The second program is a special coverage in the remaining states. Under our special coverage, should a vehicle ever experience this condition, the owner must take that vehicle to their GM dealer and have that dealer inspect the vehicle, confirm the condition, and then repair that vehicle for free.

Your vehicle is covered by this special coverage.

Do not take your vehicle to your GM dealer as a result of this letter unless you believe that your vehicle has the condition as described above.

What You Should Do: If your vehicle demonstrates the condition or symptoms described above, contact your GM dealer to schedule an inspection. Please note that repairs and adjustments qualifying under this special coverage **must** be performed by a GM dealer. Your dealer can tell you how long they will need your vehicle.

If your vehicle does not currently demonstrate this condition, you should keep this document in a safe place for future reference. You should not take your vehicle to your GM dealer unless these symptoms have been observed. **Diagnosis or repair for conditions other than that described above is not covered under this special coverage program (and will be your responsibility).**

Reimbursement: If you have paid for repairs for the condition described in this letter, please complete the enclosed form and present it to your dealer with all required documents. Working with your dealer will expedite your request, however, if this is not convenient, you may mail the completed form and all required documents to Reimbursement Department, PO Box 33170, Detroit, MI 48232-5170. The completed form and required documents must be presented to your dealer or received by the Reimbursement Department by January 31, 2014, unless state law specifies a longer reimbursement period.

If you have any questions or need any assistance, just contact your dealer or the appropriate Customer Assistance Center at the number listed below.

Division	Number	Text Telephones (TTY)
Buick	1-800-521-7300	1-800-832-8425
Chevrolet	1-800-222-1020	1-800-833-2438
GMC	1-800-462-8782	1-888-889-2438
Guam	65-6267-1752	
Puerto Rico – English	1-800-496-9992	
Puerto Rico – Español	1-800-496-9993	
Virgin Islands	1-800-496-9994	

We are sorry for any inconvenience you may experience; however we have taken this action in the interest of your continued satisfaction with our products.

Jim Moloney
General Director,
Customer and Relationship Services

Enclosure
11323