



# Service Bulletin

File in Section: 07 - Transmission/Transaxle

Bulletin No.: 09-07-30-001F

Date: June, 2013

## TECHNICAL

**Subject:** Transmission Shudder or Bucking Feel (Follow Procedure Outlined Below)

**Models:** 2009 Cadillac Escalade  
2008-2009 Chevrolet Tahoe  
2008-2009 GMC Yukon  
Equipped with 2 Mode Hybrid Automatic Transmission (RPO M99)  
Built Prior to Serial Date 8010017028

This bulletin is being revised to update the Correction and Warranty Information. Please discard Corporate Bulletin Number 09-07-30-001E.

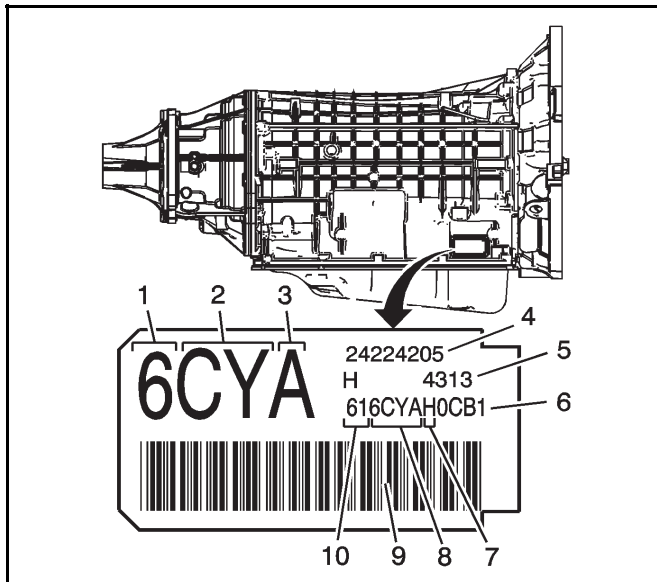

1963763

Refer to the illustration above to locate the sequential serial number (6).

### Condition

Some customers may comment that the vehicle has a shudder, bucking or surge feel (similar to a severe engine misfire) when driving with the internal combustion engine running. The concern may be more noticeable in cold ambient temperatures and with transmission cold, but may also be present after the vehicle and transmission are up to operating temperature. The concern can also be noticeable at highway speeds.

### Cause

This condition may be caused by a restricted line pressure decrease orifice.

### Correction

To verify the concern is caused by the orifice, monitor the Hybrid Low 1-2 clutch slip speed (clutch 1 on the scan tool). Normal clutch slip speed should be 0 rpm. If the slip speed varies either positive or negative slip rpm, or causes other clutch slip speeds to read erratic, the orifice is most likely restricted (see scan tool screen shot below showing variation of the clutch 1 slip speed (circled area). Normal reading would have a flat line (0 rpm).

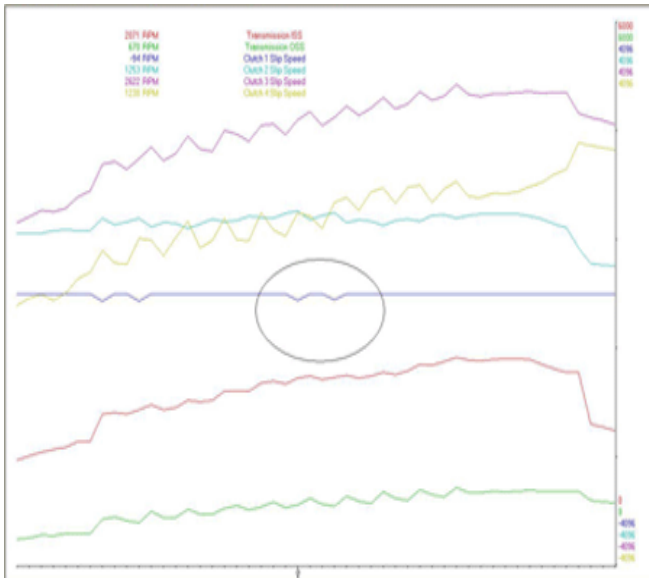

2535182

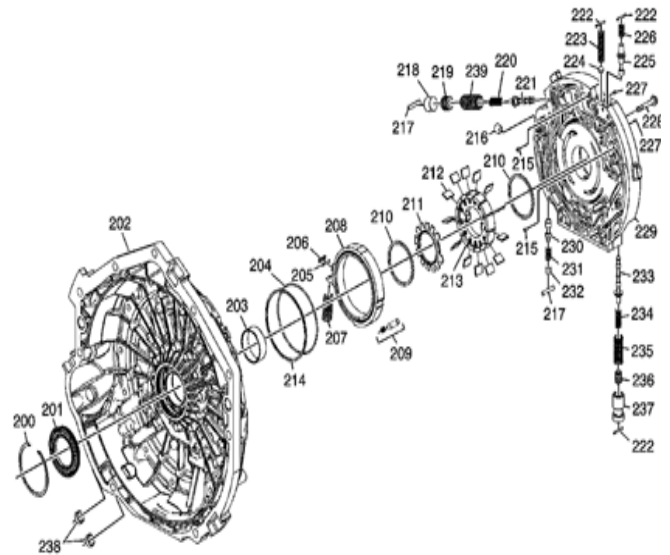

2534709

1. Remove the transmission.
2. Separate the torque dampener housing from the transmission.

4. Replace the fluid pump cover kit. The cover kit is shown as part number 229 in the picture above.
5. Install the torque dampener housing to the transmission.
6. Install the transmission.

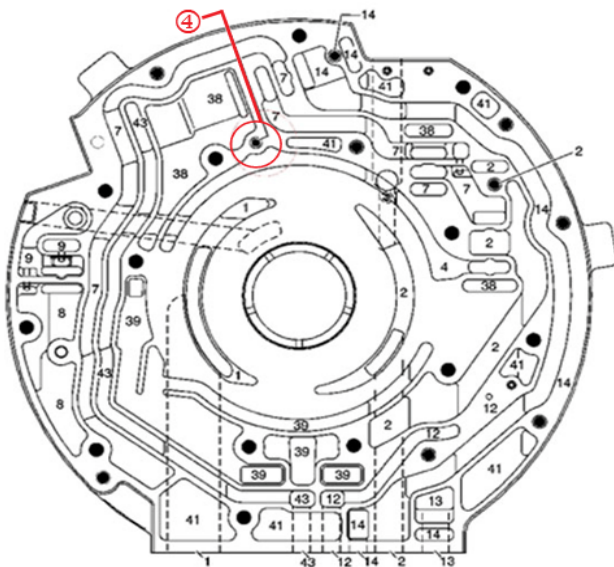

2707874

3. Remove and discard the orifice cup plug in the pump cover. The location is shown above (callout #4).

### Warranty Information

For vehicles repaired under warranty, use:

Labor Operation	Description	Labor Time
8464730	Torque Dampener Replacement	Use Published Labor Operation Time

