

NUMBER: 25-004-13

GROUP: Emissions Control

DATE: September 12, 2013

This bulletin is supplied as technical information only and is not an authorization for repair. No part of this publication may be reproduced, stored in a retrieval system, or transmitted, in any form or by any means, electronic, mechanical, photocopying, or otherwise, without written permission of DaimlerChrysler Corporation.

THIS BULLETIN SUPERSEDES SERVICE BULLETIN 25-001-07, DATED FEBRUARY 9, 2007, WHICH SHOULD BE REMOVED FROM YOUR FILES. ALL REVISIONS ARE HIGHLIGHTED WITH **ASTERISKS****. THIS BULLETIN ALSO INCLUDES THE ADDITION OF LIFETIME WARRANTY EXTENSION X51.**

SUBJECT:

I/M Readiness Check Continues To Indicate OBD System Is Not Ready For I/M Testing (X51 Lifetime Warranty Extension)

OVERVIEW:

This bulletin involves modifying wiring in the Power Distribution Center (PDC).

MODELS:

2005 - 2006 (TJ) Wrangler

NOTE: This Extended Warranty Bulletin applies to vehicles equipped with a 2.4L or 4.0L engine (sales code ED1 or ERH respectively).

SYMPTOM/CONDITION:

****The Catalyst Monitor, Oxygen Sensor Monitor, and Oxygen Sensor Heater Monitors may indicate "Not Ready" even if the monitor is operating correctly and determining pass/fail results. Two or more monitors indicating "Not Ready" will result in vehicle rejection during an I/M test. In addition, the vehicle On Board Diagnostics (OBD) system may not indicate readiness for I/M emissions testing during the key-on test. (See 'Emissions Inspection and Maintenance Programs' in section 7 of the Wrangler owner's manual to determine if vehicle is ready for I/M testing).****

DIAGNOSIS:

After turning ignition key to the ON position **without** cranking the engine, the Malfunction Indicator Lamp (MIL) should remain illuminated solid. If the MIL flashes for 10 seconds approximately 15 seconds **after** turning the key to the ON position (without cranking the engine) and then returns to solid illumination, the vehicle is not ready for I/M testing. Perform the Repair Procedure.

PARTS REQUIRED:

Qty.	Part No.	Description
AR	NPN	Solder, Rosin Core
2	05018395AA	Kit, Splice

SPECIAL TOOLS/EQUIPMENT REQUIRED:

05019912AA	MOPAR Crimping Tool
NPN	Soldering Iron
NPN	Heat Gun

REPAIR PROCEDURE:

1. Remove and isolate the positive and negative battery cables from the battery.
2. Remove the Power Distribution Center (PDC) cover from the PDC.
3. Locate the ASD (Auto Shut Down) and the Fuel Pump relays in the PDC.
4. Remove the two nuts used to secure the positive battery cable to the PDC. Remove the positive battery cable from the PDC.
5. Remove the PDC from its bracket and remove the cover from the bottom of the PDC to expose the underside wiring.
6. Locate the terminal end in PDC cavity A13 that connects to the ASD relay pin 85. Two 20 gauge wires, each of PK/WT color, are crimped to this terminal end (Fig. 1).

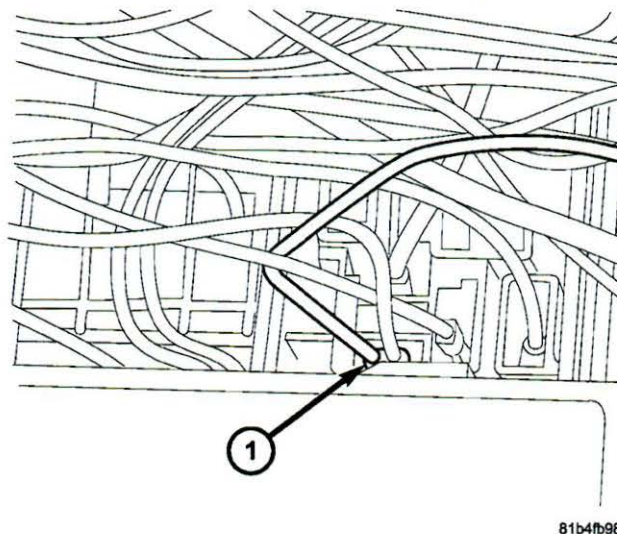

Fig. 1 TWO 20 GA. PK WT WIRES IN CAVITY A13

1 - TWO 20 GA. PK/WT WIRES - AT PDC CAVITY A13 (FOR ASD RELAY PIN 85)

7. At PDC cavity A13 (ASD), locate the one PK/WT wire that connects to the fuel pump relay terminal.
8. Cut the PK/WT wire, that connects to the fuel pump relay, as close to the PDC cavity A13 terminal as possible (Fig. 2).

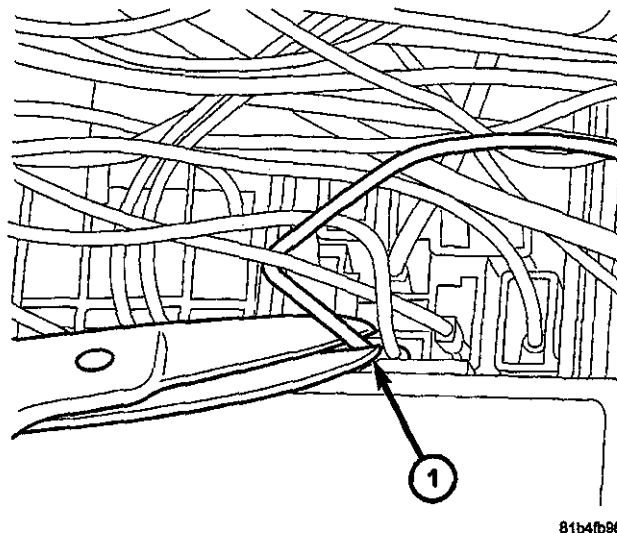

Fig. 2 CUT ASD 20 GA. PK WT TO FUEL PUMP

1 - CUT PDC CAVITY A13 PKWT WIRE THAT GOES TO THE FUEL PUMP RELAY CLOSE TO TERMINAL

-
9. At the same PDC cavity A13, cut the other PK/WT wire approximately 2 inches from the terminal.
 10. There are now three (3) PK/WT wires. Strip approximately 0.25 inches of the insulation from the ends of all three PK/WT wires.
 11. Splice the one PK/WT wire leading from fuel pump relay to the one PK/WT wire leading from wire harness bundle with convolute (Fig. 4). **Be sure to slide shrink tube over wire before crimping.** Splice the wires with kit p/n 05018395AA.

NOTE: The remaining ASD relay wire in PDC cavity A13 (2 inch lead) should not be connected to anything at this point.

12. Locate the RD/YL 18 gauge wire connected to the terminal end in PDC cavity A15. This wire connects the ASD relay pin 30 to fuse #9 (ASD power) in the PDC.
13. Cut this wire approximately 2 inches from the PDC cavity A15 terminal (ASD relay pin 30) (Fig. 3).

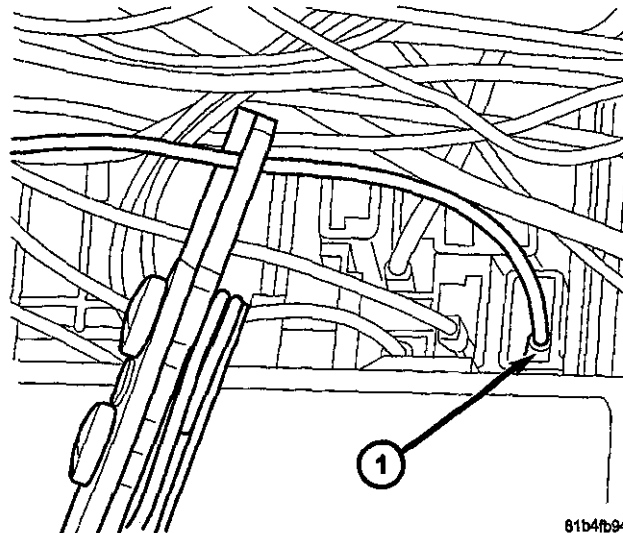
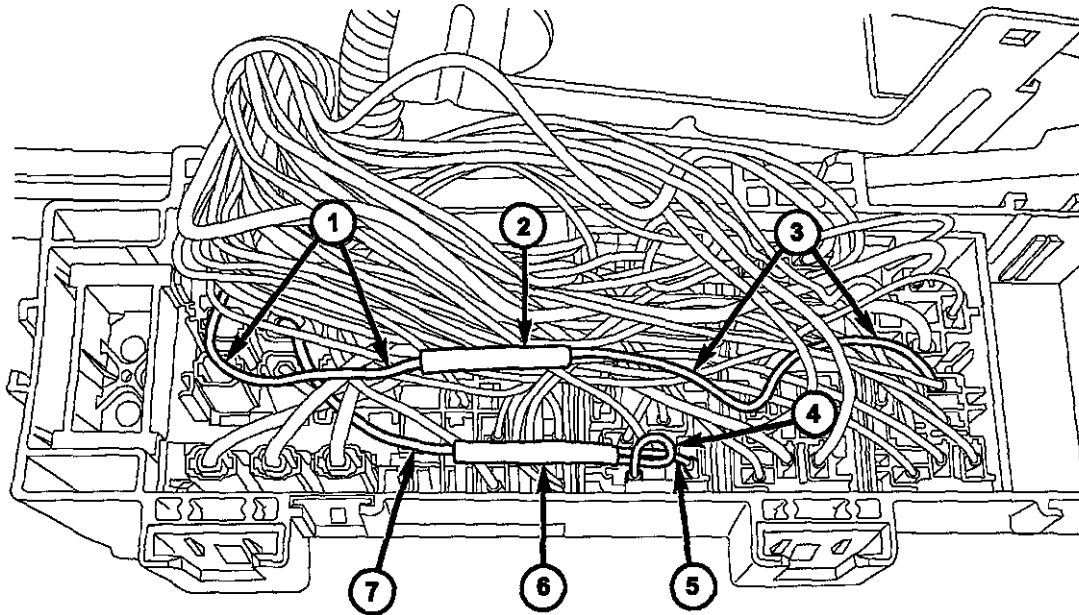

Fig. 3 CUT ASD 18 GA. RD YL WIRE IN CAVITY A15

1 - CUT PDC CAVITY A15 18 GA. RD/YL WIRE THAT GOES TO ASD RELAY PIN 30 TWO INCHES FROM TERMINAL

-
14. Strip approximately 0.25 inches of insulation from both ends of the RD/YL wire cut in Step #13.
 15. Splice the two RD/YL wires to the one remaining PK/WT wire (2 inch lead at A13) together (Fig. 4). **Be sure to slide shrink tube over wire before crimping.** Splice the wires with kit p/n 05018395AA.
 16. After both splices are complete, solder crimp splices with non-acid core solder.
 17. Slide shrink tube over soldered splices and shrink with a heat gun until sealant is visible on both ends of the splice (Fig. 4).



81c35903

Fig. 4 COMPLETED WIRE SPLICES

- 1 - 20 gauge PK/WT wire from wire harness bundle with convolute
- 2 - Splice repair (2 wires)
- 3 - 20 gauge PK/WT wire from fuel pump relay
- 4 - 20 gauge PK/WT wire from PDC cavity A13 for ASD relay pin 85
- 5 - 18 gauge RD/YL wire from PDC cavity A15 for ASD relay pin 30
- 6 - Splice Repair (3 wires)
- 7 - 18 gauge RD/YL wire from PDC fuse #9 for ASD power

-
- 18. Install the cover on the bottom of the PDC.
 - 19. Install the PDC to its bracket.
 - 20. Install the positive battery cable to the PDC. Tighten both attaching nuts to 11.3 Nm (100 in. lbs.).
 - 21. Install the positive and negative battery cables from the battery.
 - 22. Set the clock to the correct time.
 - 23. After the Repair Procedure is completed, the vehicle will need to be driven to update the OBD system. It may require several days of normal drive cycles to update all of the required OBD monitors.
 - a. The vehicle is ready for I/M emissions testing when the Malfunction Indicator Lamp (MIL) remains illuminated continuously after turning the ignition key to the ON position **without** cranking the engine.
 - b. The vehicle is NOT ready for I/M emissions testing, when the MIL flashes for 10 seconds approximately 15 seconds **after** turning the key to the ON position (without cranking the engine) and then returns to continuous illumination. The vehicle will require further drive cycles. If this condition persists after several days of further drive cycles, then additional diagnosis may be required.

POLICY:

Reimbursable within the provisions of the warranty.

NOTE: Vehicles included in this Service Bulletin have a lifetime coverage warranty for this repair. See Warranty Bulletins; U.S. D-13-38, Canada SAB-2013-29 or International ID-13-12 for details associated with the extended warranty.

TIME ALLOWANCE:

Labor Operation No:	Description	Amount
08-90-65-90	MIL continues to indicate OBD system is not ready for testing - Repair (B)	0.8 Hrs.

FAILURE CODE:

ZZ	Service Action
----	----------------