



Service Bulletin

File in Section: -

Bulletin No.: PIP4988A

Date: February, 2013

PRELIMINARY INFORMATION

Subject: Objectionable Underhood Odor From The Coolant - Flush Cooling System And Replace Rubber Hoses

Models: 2012-2013 Chevrolet Camaro
Built Prior to June 15, 2012

This PI was superseded to update parts information. Please discard PIP4988.

The following diagnosis might be helpful if the vehicle exhibits the symptom(s) described in this PI.

Condition/Concern

Some customers may comment on an objectionable underhood odor that is coming from the engine coolant.

The odor is a by-product in the rubber curing process that continues after the vehicle is produced.

The odor is temporary; noticed early in the life of the vehicle; often in warmer climates and is usually gone completely in the first couple of months after production.

Recommendation/Instructions

If the condition persists, the system should be flushed and the coolant hoses replaced with the updated part numbers listed below.

If this concern is encountered, follow the procedure below to clean the cooling system:

1. Completely drain the cooling system by following the SI Cooling System Draining and Filling procedure. If equipped with a block heater, remove it as well. If equipped, also remove the engine block plug shown below.

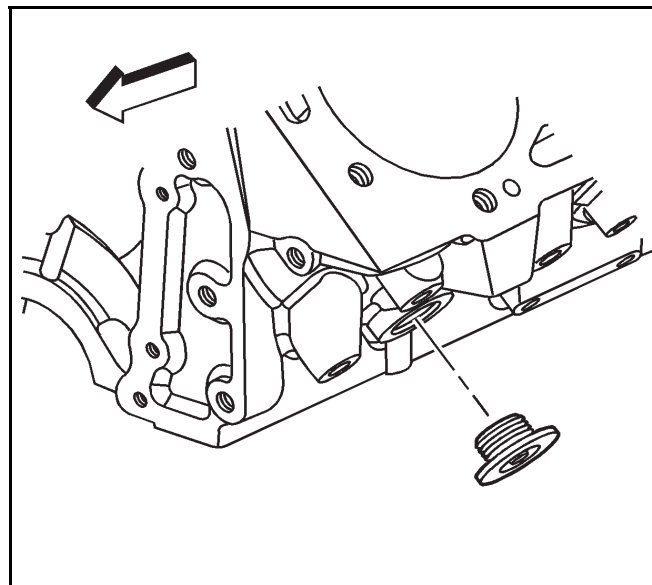

635657

2. Remove the thermostat and reassemble without the thermostat in place. Refer to SI procedures for the removal procedure.

3. Fill the cooling system by following the SI Cooling System Draining and Filling procedure but instead of filling with a 50/50 mix of coolant and water, fill the cooling system with drinkable water and one bottle of GM Heavy Duty Cooling System Cleaner. Avoid spilling the solution on the vehicle's finish. This cleaner is in liquid form and contains a neutralizer. Do not substitute other cleaners.
4. Drive the vehicle for 40-60 minutes with the heat on high.
5. Stop the engine and allow it to cool.
6. Drain the cooling system by following the SI Cooling System Draining and Filling procedure. Also, drain the engine block by removing the engine block plug. If equipped with a block heater, remove it as well.
7. Fill the cooling system by following the SI Cooling System Draining and Filling procedure but instead of filling with a 50/50 mix of coolant and water, fill the cooling system with clean, drinkable water.
8. Run the engine for 10 minutes to circulate the water.
9. Stop the engine and allow it to cool.
10. Repeat steps 6 through 9.
11. Drain the cooling system by following the SI Cooling System Draining and Filling procedure. Also, drain the engine block by removing the engine block plug. If equipped with a block heater, remove it as well.
12. Remove the surge tank. Thoroughly clean it with hot water and install it again.
13. Fill the cooling system by following the SI Cooling System Draining and Filling procedure but instead of filling with a 50/50 mix of coolant and water, fill the cooling system with plain drinkable water.
14. Run the engine for 10 minutes to circulate the water.
15. Stop the engine and allow it to cool.
16. Drain the cooling system by following the SI Cooling System Draining and Filling procedure. Also, drain the engine block by removing the engine block plug. If equipped with a block heater, remove it as well.
17. Replace all rubber cooling system hoses following SI procedures.
18. Install the thermostat using a new water pump inlet seal. Refer to SI procedures for the installation procedure.

Important: Only use Premixed DEX-COOL® or a 50/50 mix of DEX-COOL and clean, drinkable water when refilling the cooling system.

19. Fill the cooling system by following the SI Cooling System Draining and Filling procedure.
20. Test drive the vehicle, allow to cool and double check the coolant level to complete the repair.

Parts Information

Part Number	Description
22962575	All V-6 - HOSE-ENG COOL AIR BL
22962574	All V-6 - HOSE-HTR INL
22962565	All V-6 - HOSE-RAD INL
22962573	All V-6 - HOSE-HTR OTLT
22962568	All V-6 - HOSE-RAD OTLT
22962572	All V-8 - HOSE-ENG COOL AIR BL
22962569	All V-8 - HOSE-RAD OTLT
22962570	All V-8 - HOSE ASM-HTR INL & OTLT
22962571	All V-8 - HOSE-RAD INL
22962567	V8 Engine RPO LSA - HOSE-ENG COOL AIR BL
22962566	V8 Engine RPO LSA -HOSE-CHRG AIR CLR COOL
88861344	GM Heavy Duty Cooling System Cleaner
88861345	GM Heavy Duty Cooling System Cleaner (Canada Only)

Warranty Information

For vehicles repaired under warranty use:

Labor Operation	Description	Labor Time
J3540	Flush Cooling System	Use Published Labor Time in Combination with Necessary Straight Time

Please follow this diagnostic or repair process thoroughly and complete each step. If the condition exhibited is resolved without completing every step, the remaining steps do not need to be performed.