



**NUMBER:** 08-085-13

**GROUP:** Electrical

**DATE:** October 26, 2013

*This bulletin is supplied as technical information only and is not an authorization for repair. No part of this publication may be reproduced, stored in a retrieval system, or transmitted, in any form or by any means, electronic, mechanical, photocopying, or otherwise, without written permission of Chrysler Group LLC.*

**SUBJECT:**

NHJ Heated Mirror Inoperative

**OVERVIEW:**

This bulletin involves installing a wire harness service kit.

**MODELS:**

2013 (FF) 500/500e (Mexico only)

**NOTE:** This bulletin applies to vehicles built on or after August 15, 2013 (MDH 0815XX) and on or before August 29, 2013 (MDH 0829XX) equipped with Heated Exterior Mirrors (sales code NHJ).

**SYMPTOM/CONDITION:**

A customer may experience exterior mirrors heating feature is inoperative. On further inspection no DTC's will be found.

**DIAGNOSIS:**

If the customer describes the symptom, perform the Repair Procedure.

**SPECIAL TOOLS/EQUIPMENT REQUIRED:**

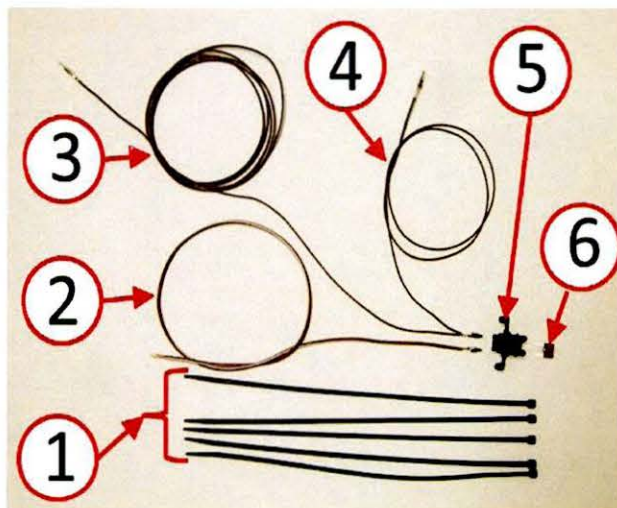
NPN	Soldering Iron
1	0105019912AA Mopar (Miller Tool # 10042)

**PARTS REQUIRED:**

Qty.	Part No.	Description
1	68209660AA	Wiring Kit - Heated Mirror
1	05018528AA	1 XLg Splice Band and Heat Shrink Tubing

**REPAIR PROCEDURE:**

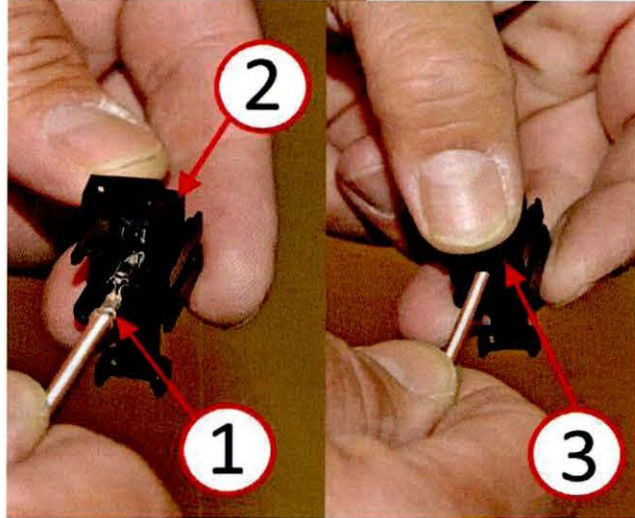
1. Open the wire harness service kit package (Fig. 1) and assemble the heated mirror wire harness per the following steps.



**Fig. 1 Heated Mirror Wire Harness Kit**

- 1 - Cable Ties.
- 2 - Wire C15 BR-WT
- 3 - Long Wire F814 BR-BK
- 4 - Short Wire F814 BR-BK
- 5 - Fuse Holder
- 6 - Fuse

- 
2. Insert terminal of wire C15 BR-WT (1) into fuse holder (2) then close terminal lock (3) (Fig. 2).

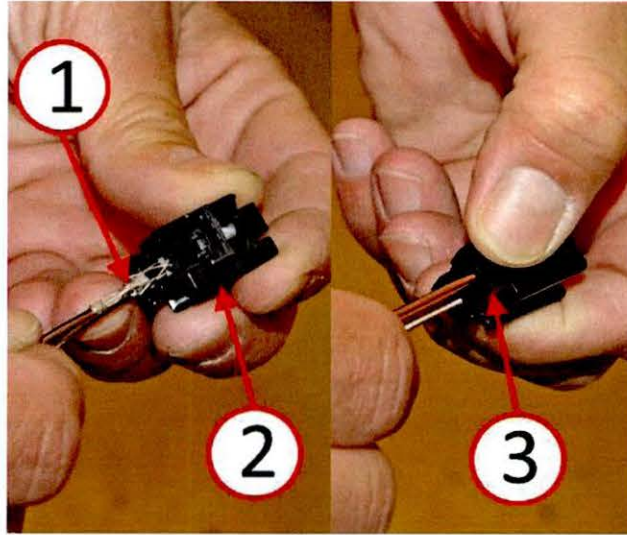


**Fig. 2 Insert Wire C15 Into Fuse Holder**

- 1 - Wire C15 BR-WT
- 2 - Fuse Holder
- 3 - Terminal Lock

---

3. Insert shared terminal of wires F814 BR-BK (1) into fuse holder (2) then close terminal lock (3) (Fig. 3).

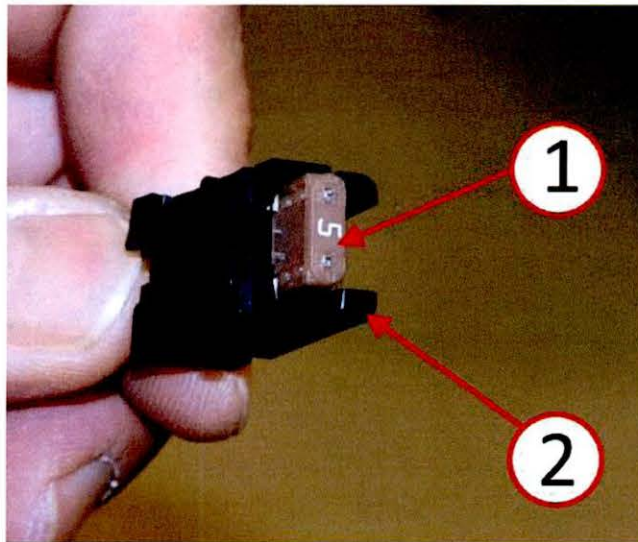


**Fig. 3 Insert Wire Pair F814 Into Fuse Holder**

- 1 - Wires F814 BR-BK Shared Terminal
- 2 - Fuse Holder
- 3 - Terminal Lock

---

4. Insert 5 amp fuse (1) into fuse holder (2) (Fig. 4).

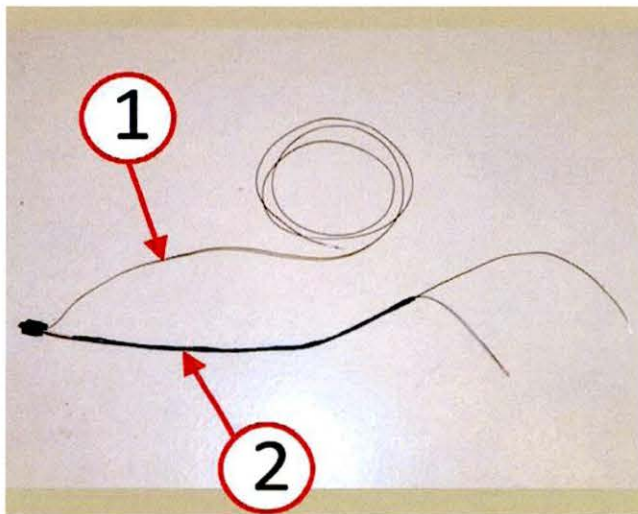


**Fig. 4 Insert Fuse Into Fuse Holder**

- 1 - Fuse
  - 2 - Fuse Holder
-



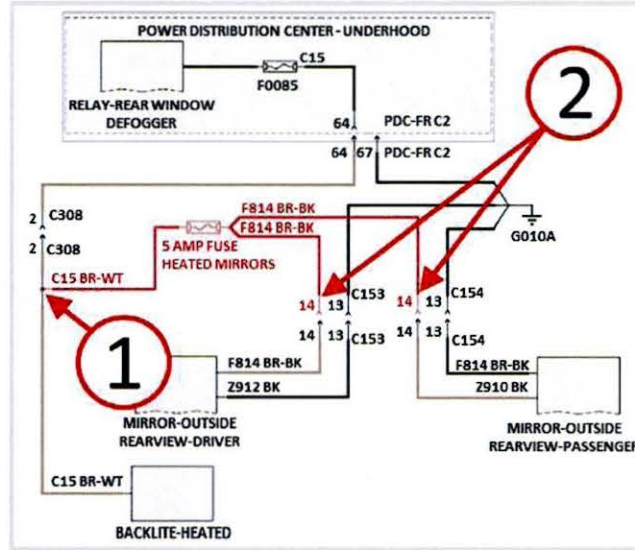
5. Tape together the two shorter wires F814 BR-BK and C15 BR-WT (2) with electrical tape, leaving at least 100mm (4.0 in.) exposed at the end for making electrical connections (Fig. 5).



**Fig. 5 Assembled Heated Mirror Wire Harness**

- 1 - Wire F814 BR-BK Long
- 2 - Wires F814 BR-BK Short and C15 BR-WT

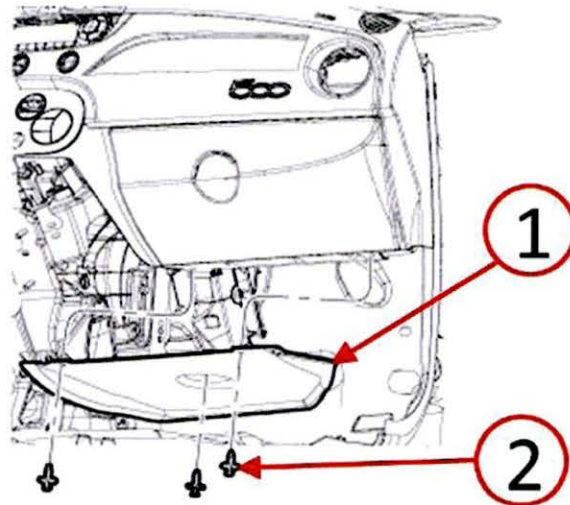
- 
6. The assembled heated mirror wire harness will be connected to the backlite power supply (1) and rearview mirrors (2) per the following steps (Fig. 6).



**Fig. 6 Wire Diagram**

- 1 - Heated Backlite Power Supply Splice
- 2 - Door Inline Electrical Connections

7. Disconnect the vehicle battery negative cable. Refer to the detailed repair procedures available in: DealerCONNECT> TechCONNECT under: Service Info> 08 - Electrical> 8F - Engine Systems> Battery System> BATTERY> Removal.
8. Remove the left and right cowl/scuff panel trim. Refer to the detailed repair procedures available in: DealerCONNECT> TechCONNECT under: Service Info> 23 - Body> Interior> PANEL, Cowl Trim, Side> Removal.
9. Remove the instrument panel trim. Refer to the detailed repair procedures available in: DealerCONNECT> TechCONNECT under: Service Info> 23 - Body> Instrument Panel> PANEL, Instrument Panel Trim> Removal.
10. Remove the instrument panel closeout fasteners (2) (Fig. 7).
11. Remove the instrument panel closeout panel (1) (Fig. 7).

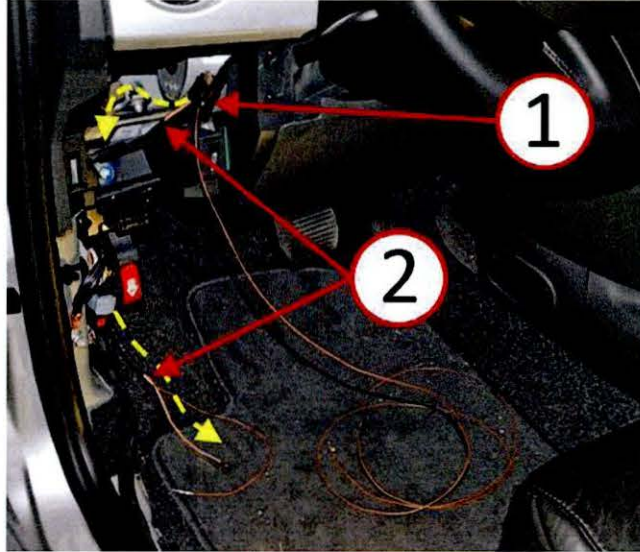


**Fig. 7 Closeout Panel**

- 1 - Closeout Panel.
- 2 - Push Pin Fasteners

- 
12. Using a cable tie, attach the heated mirror wire harness fuse holder to the front body wire harness at the location shown (1) and cut off the excess cable tie (Fig. 8).
  13. Guide the taped wire pair (2) through the instrument panel structure, following the route of the rear body wire harness to the left front door inline electrical connector C153 (Fig. 8).

**CAUTION: Make sure that the wire will not interfere with any pedals (clutch, brake and accelerator).**



***Fig. 8 Fuse Holder Mounting And Harness Routing***

1 - Fuse Holder

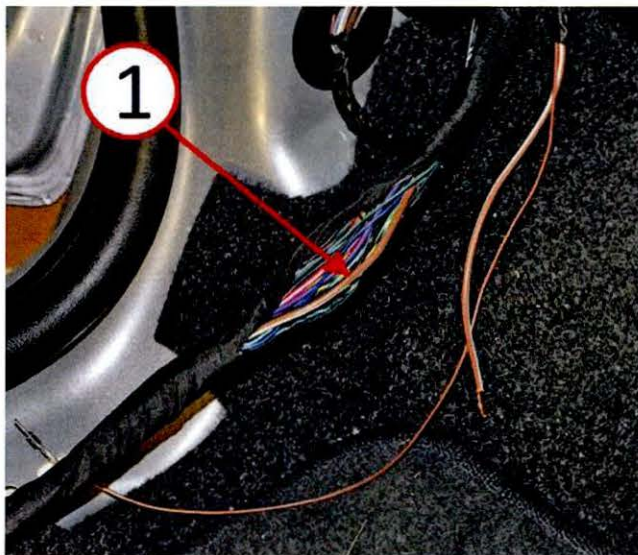
2 - Wires F814 BR-BK Short and C15 BR-WT

---

**CAUTION: Take care not to cut or damage wire harness while removing the abrasion tape.**

14. Remove the abrasion tape from at least 150mm (6.0 in.) of the rear body wire harness (driver side) and locate the heated backlite wire (Brown/White) (Fig. 9).

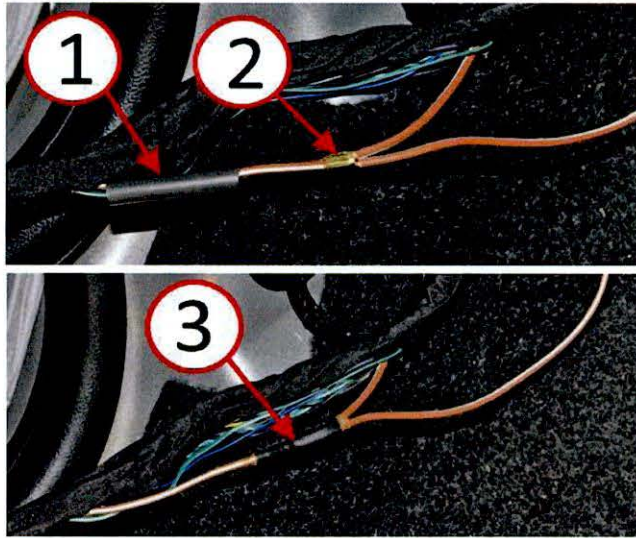




**Fig. 9 Locate Circuit Wire C15 In Rear Body Harness**

1 - Heated Backlamp Wire.

- 
15. Using splice band (2) and heat shrink tubing (1), splice heated mirror circuit wire C15 BR-WT with heated backlite circuit wire C15 BR-WT (3) (Fig. 10). Refer to the detailed repair procedures available in: DealerCONNECT> TechCONNECT under: Service Info> 29 - Non-DTC Diagnostics> Circuit Testing Procedures> Standard Procedure> WIRE SPLICING.

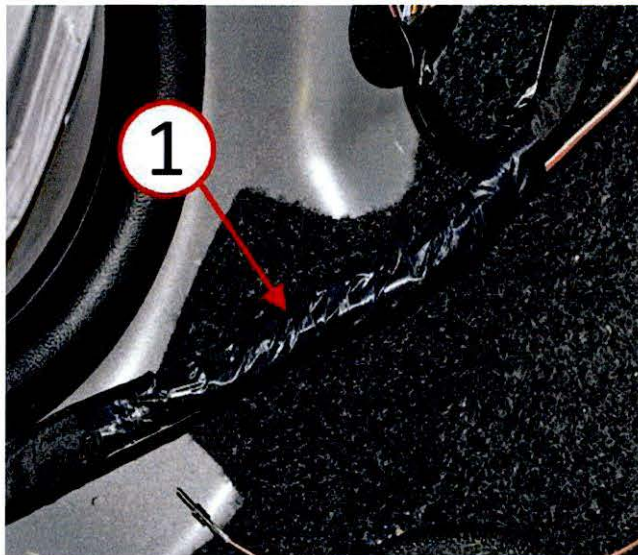


**Fig. 10 Splice Wires**

- 1 - Heat Shrink Tubing
- 2 - Band Clamp
- 3 - Completed Splice

---

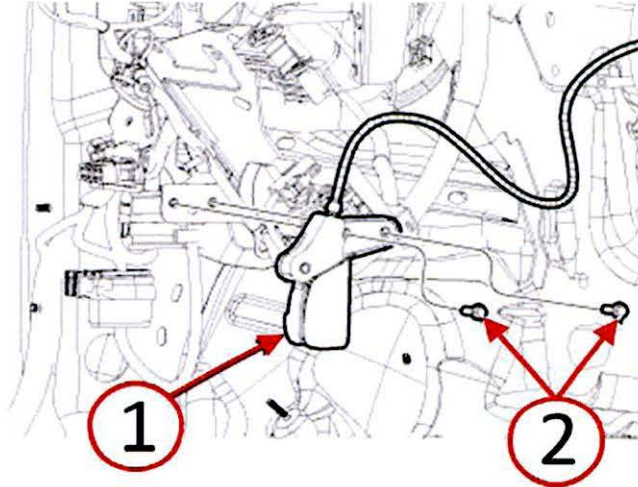
16. Apply electrical tape to cover the splice in the rear main wire harness (Fig. 11).



**Fig. 11 Wrap Rear Body Harness**

- 1 - Electrical Tape.
-

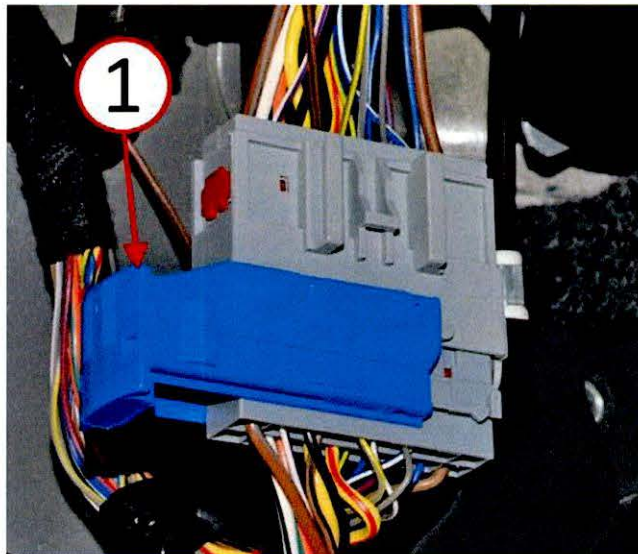
17. Remove the hood release lever fasteners (2) and position aside the lever (1) for access to the left door inline electrical connector (Fig. 12).



**Fig. 12 Hood Release Lever**

- 1 - Hood Release Lever
- 2 - Fasteners

18. Disconnect the left front door inline electrical connector C153 by sliding the blue electrical connector lock (Fig. 13).

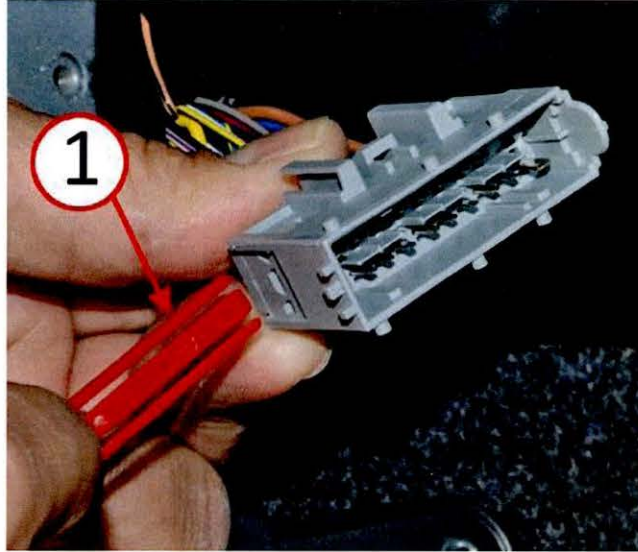


**Fig. 13 Left Door Inline Electrical Connector Unlock**

- 1 - Electrical Connector Lock



19. Remove the red electrical terminal lock wedge from the body side electrical connector C153 (Fig. 14).

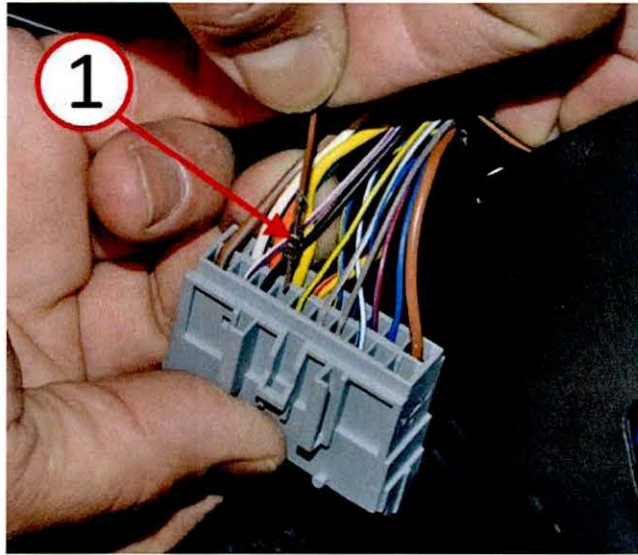


**Fig. 14 Electrical Connector Terminal Retainer**

1 - Terminal Lock Wedge

- 
20. Insert the terminal of the shorter F1814 BR-BK heated mirror wire into the body side electrical connector C153 cavity 14. Push in until the terminal clicks into the connector. Gently pull back on the terminal to ensure it is securely locked in the connector (Fig. 15).

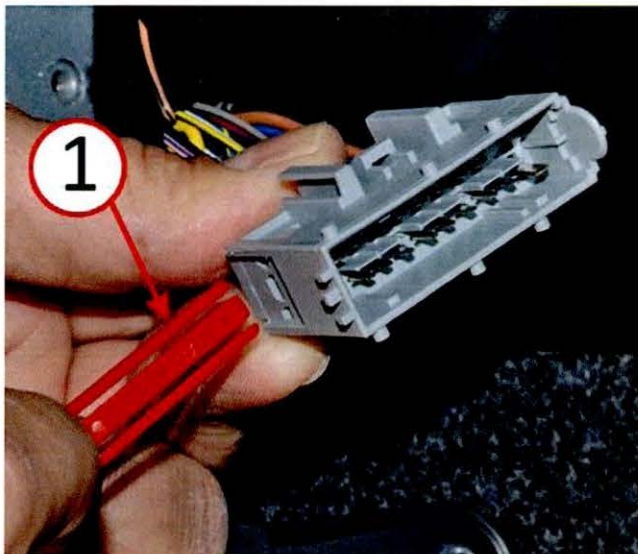




**Fig. 15 Left Heated Mirror Wire Terminal**

1 - Heated Mirror Wire Terminal

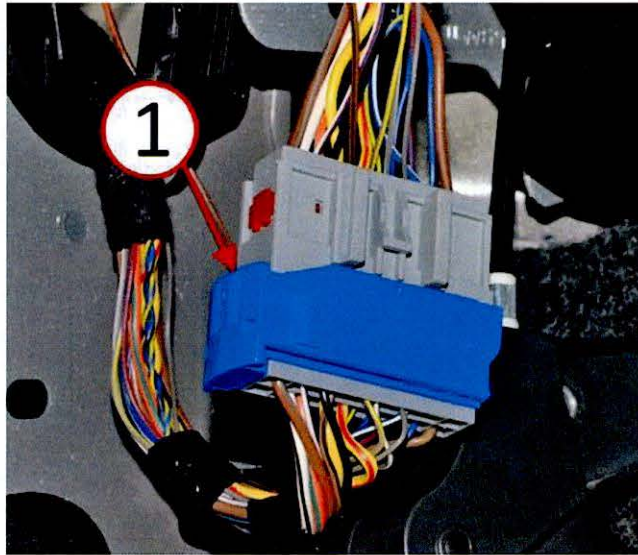
- 
21. Install the red electrical terminal lock wedge to the body side electrical connector C153 (Fig. 16)



**Fig. 16 Electrical Connector Terminal Retainer**

1 - Terminal Lock Wedge

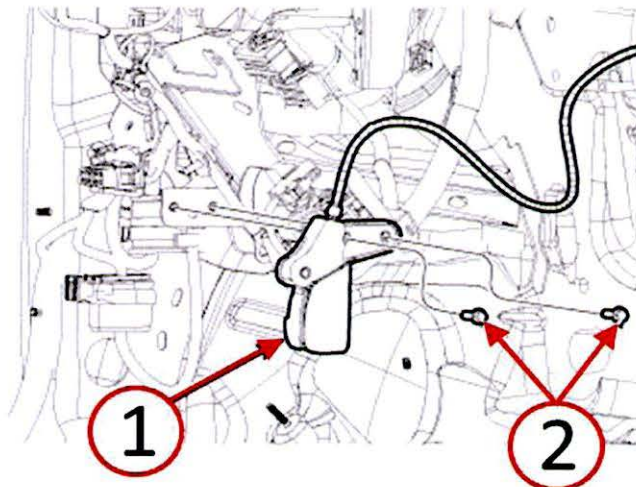
- 
22. Connect the left front door inline electrical connector C153 by sliding the blue electrical connector lock (Fig. 17).



**Fig. 17 Left Door Inline Electrical Connector Lock**

1 - Electrical Connector Lock

- 
23. Install the hood release lever (1) and fasteners (2) (Fig. 18). Refer to the detailed repair procedures available in: DealerCONNECT> TechCONNECT under: Service Info> 23 - Body> Hood> CABLE, Hood Release> Installation.



**Fig. 18 Hood Release Lever**

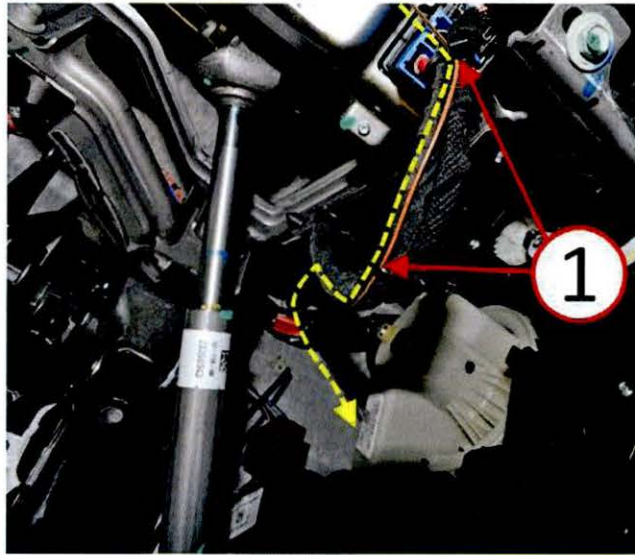
1 - Hood Release Lever

2 - Fasteners

---

**CAUTION: Make sure that the wire will not interfere with any pedals (clutch, brake and accelerator).**

24. Guide the longer F814 BR-BK heated mirror wire through the instrument panel structure following the route of the front body wire harness to the passenger door inline electrical connector C154. Use cable ties to secure the longer F1814 BR-BK wire to the front body main wire harness bundle (Fig. 19) and (Fig. 20).

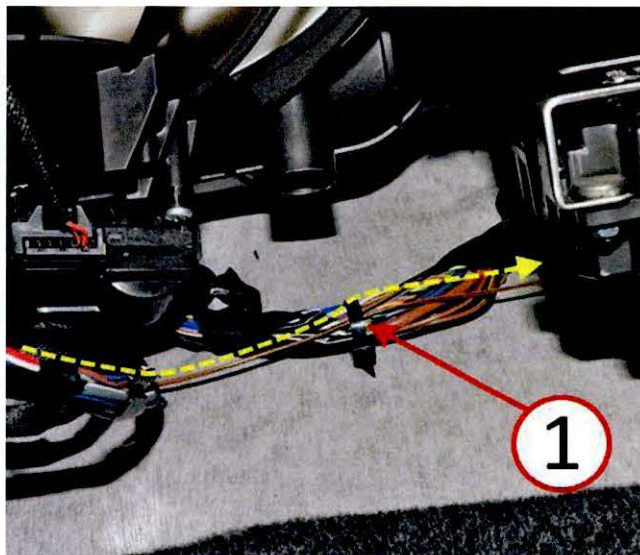


***Fig. 19 Right Hand Heated Mirror Wire Routing Driver Side***

1 - Heated Mirror Wire F1814 BR-BK Long

---

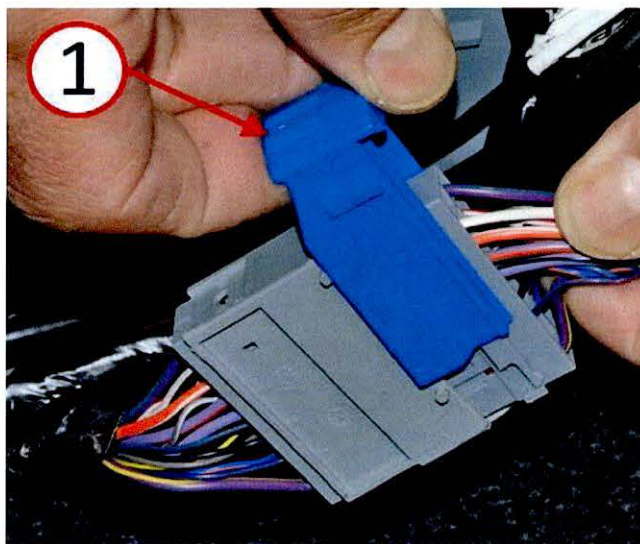




**Fig. 20 Right Heated Mirror Wire Routing Passenger Side**

1 - Heated Mirror Wire F1814 BR-BK Long

- 
25. Disconnect the right front door inline electrical connector C154 by sliding the blue electrical connector lock (Fig. 21).

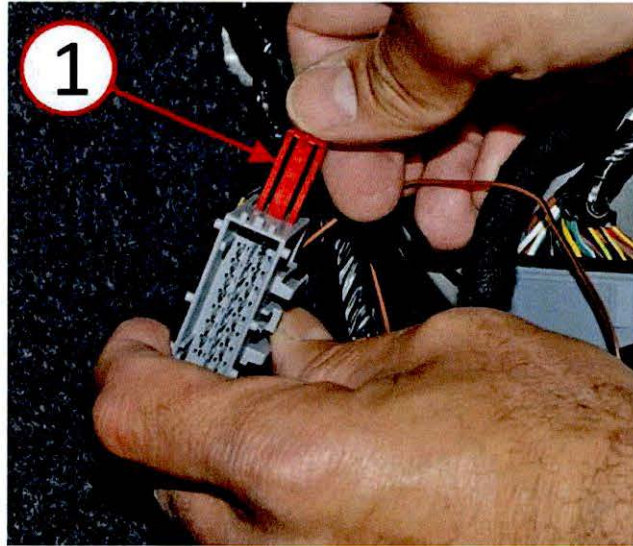


**Fig. 21 Right Door Inline Electrical Connector Unlock**

1 - Electrical Connector Lock

- 
26. Remove the red electrical terminal lock wedge from the body side electrical connector C154 (Fig. 22).



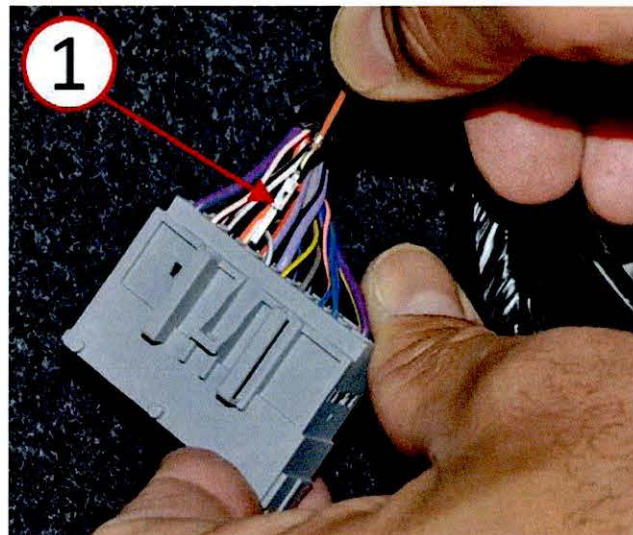


**Fig. 22 Electrical Connector Terminal Retainer**

1 - Terminal Lock Wedge

---

27. Insert the terminal of the longer F1814 BR-BK heated mirror wire into the body side electrical connector C154 cavity 14. Push in until the terminal clicks into the connector. Gently pull back on the terminal to ensure it is securely locked in the connector (Fig. 23).

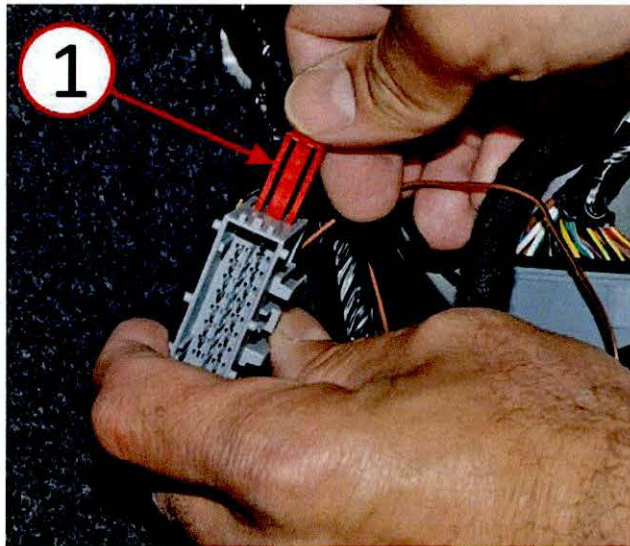


**Fig. 23 Right Heated Mirror Wire Terminal**

1 - Heated Mirror Wire Terminal

---

28. Install the red electrical terminal lock wedge to the body side electrical connector C154 (Fig. 24).

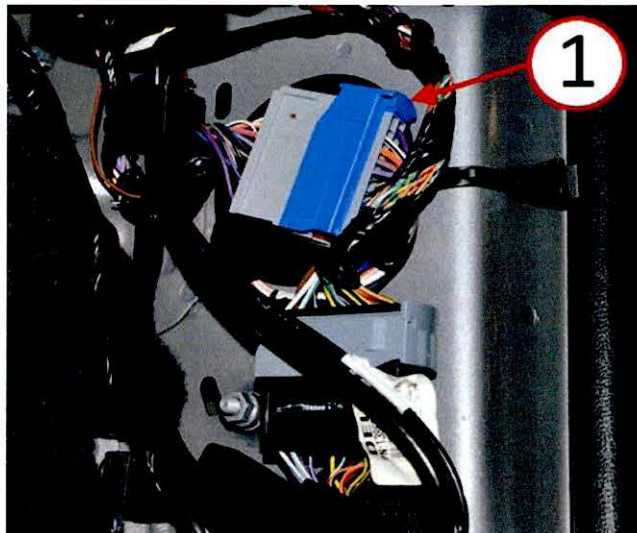


**Fig. 24 Electrical Connector Terminal Retainer**

1 - Terminal Lock Wedge

---

29. Connect the right front door inline electrical connector C154 by sliding the blue electrical connector lock (Fig. 25).



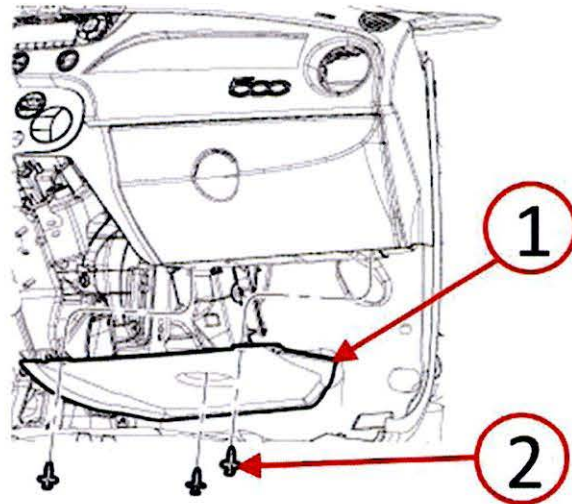
**Fig. 25 Right Door Inline Electrical Connector Lock**

1 - Electrical Connector Lock

---



- 30. Install the instrument panel closeout panel (1) (Fig. 26).
- 31. Install the instrument panel closeout fasteners (2) (Fig. 26).



**Fig. 26 Closeout Panel**

- 1 - Closeout Panel.
- 2 - Push Pin Fasteners

- 32. Install the instrument panel trim. Refer to the detailed repair procedures available in: DealerCONNECT> TechCONNECT under: Service Info> 23 - Body> Instrument Panel> PANEL, Instrument Panel Trim> Installation.
- 33. Install the left and right cowl/scuff panel trim. Refer to the detailed repair procedures available in: DealerCONNECT> TechCONNECT under: Service Info> 23 - Body> Interior> PANEL, Cowl Trim, Side> Installation.
- 34. Connect the vehicle battery negative cable. Refer to the detailed repair procedures available in: DealerCONNECT> TechCONNECT under: Service Info> 08 - Electrical> 8F - Engine Systems> Battery System> BATTERY> Installation.
- 35. To validate the heated mirror electrical harness installation, start the vehicle and turn on the heated glass button, wait a few minutes then touch the mirrors to detect if they are warm.

**POLICY:**

Reimbursable within the provisions of the warranty.

**TIME ALLOWANCE:**

Labor Operation No:	Description	Skill Category	Amount
08-92-PE-90	Install Wire Harness Service Kit (2 - Skilled)	6 - Electrical and Body Systems	1.0 Hrs.

**FAILURE CODE:**

ZZ	Service Action
----	----------------