

VANTRAAX[®]

**HKANL 23K/HKANT 23K/40K/
46K/69K23/HKAT 50K/69K25
and HKARL Specifications**

LIT NO: L629

DATE: February 2013

REVISION: H

HKANL 23K

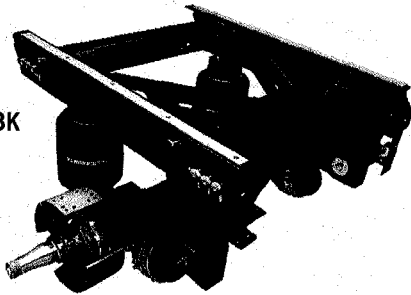

HKANT 23K

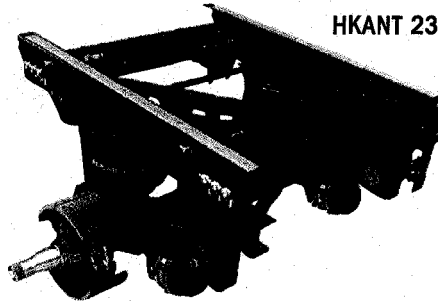

HKAT 50K

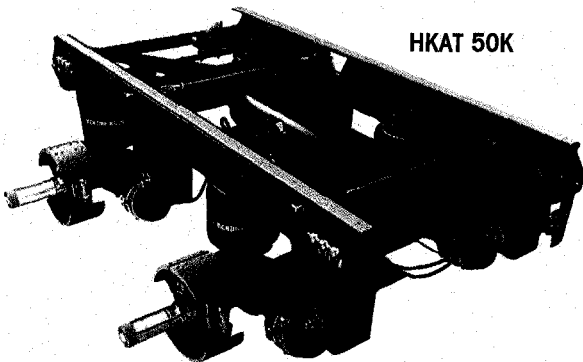

HKARL 46K

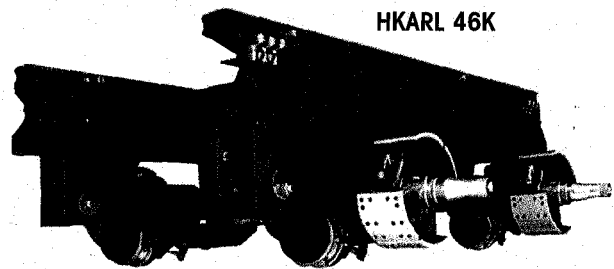

HKANT 40K and 46K

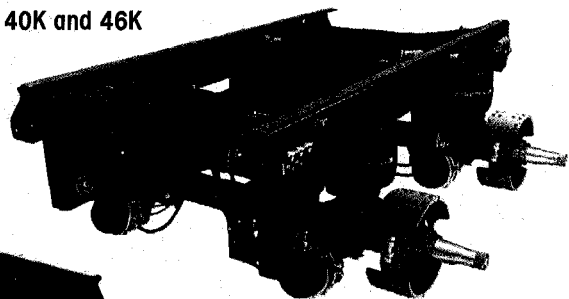

HKAT 69K25

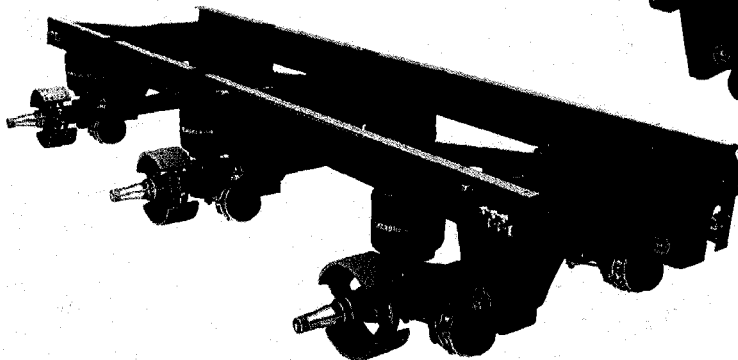



TABLE OF CONTENTS

SPECIFICATIONS

HKANL 23K3
HKANT 23K4
HKANT 40K5
HKANT 46K6
HKANT 46K - 121 Spread7
HKAT 50K8
HKANT 69K239
HKAT 69K2510
HKARL 46K11

Brake Options12

Brake Chambers12

Brake Adjusters12

READY-TO-ROLL® (RTR®)12

Height Control Valves12

OPTIONS12



HKANL 23K

SYSTEM CAPACITY*	23,000 lbs. (10 400 kg)
APPLICATION	On-highway or maintained roads; not available in "high-control" for single-axle, multi-trailer applications
TRAILER TYPES^{1,2}	U.S.A. and Canada: Dry, refrigerated and specialty van Mexico, Central and South America: None
AXLE DATA	Diameter: 5.75-inch Large-Diameter Axle (LDA™) Arrangement: Single Track: 71.5-, 77.5- and 83.5-inch Spread: N/A
FRAME TYPES	Steel only; 96- and 102-inch wide trailers (42-, 48- and 54-inch wide slider boxes)
BASE MODEL DESCRIPTION	HKANL 23K VANTRAAX® slider suspension system consisting of 48-inch wide slider box with 16- or 17-inch ride height suspension, 77.5-inch axle track, HN spindles, 16.5- x 7-inch brakes with Abex 3030-197 brake lining, ABS brackets, QUIK-ALIGN® pivot connection, QUIK-DRAW® pin-pull mechanism and standard Cam Tube System™.

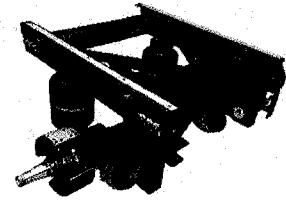

*System capacity refers to the suspension, axle and slider. Ratings for brakes and wheel-end components differ depending upon options chosen.
 1. Review tire clearance. Wheel cut outs may be necessary.
 2. Your trailer body rails must be able to support the lifted VANTRAAX System.

AXLE SPREAD (inches)	RISE HEIGHT (inches)	SYSTEM HEIGHT (inches)	FRONT AXLE LOCATION (inches)	JOUNCE (inches)	REBOUND (inches)	WEIGHT (pounds)
N/A	16	24.25	28.1	5.5	4.3	857
	17	25.25	27.9	6.5	3.3	857

Note: Weight includes 48-inch wide slider, suspension, HN Large-Diameter Axle (LDA™) (5.75-inch) and foundation brake components (body rail weights not included). For a 42-inch wide slider system, deduct 21 pounds. For a 54-inch wide slider system, add 23 pounds. For fixed-pin option, deduct 8 pounds. Does not include box shims.

SPECIFICATIONS

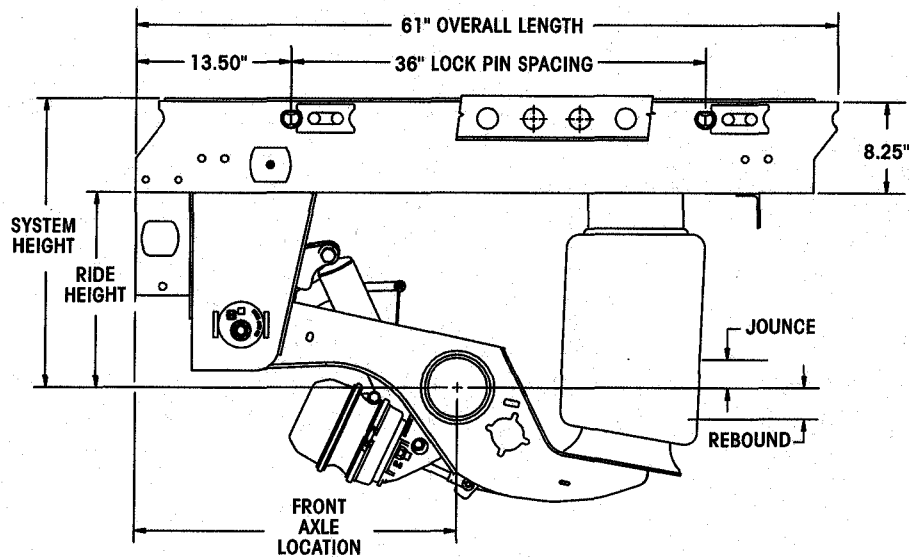

VANTRAAX® SPECIFICATIONS



HKANT 23K

SYSTEM CAPACITY*	23,000 lbs. (10 400 kg)	
APPLICATION	On-highway or maintained roads; not available in "high-control" for single-axle, multi-trailer applications	
TRAILER TYPES	U.S.A. and Canada: Dry, refrigerated and specialty van Mexico, Central and South America: None	
AXLE DATA	Diameter: 5.75-inch Large-Diameter Axle (LDA™) Arrangement: Single Track: 71.5-, 77.5- and 83.5-inch Spread: N/A	
FRAME TYPES	Steel only; 96- and 102-inch wide trailers (42-, 48- and 54-inch wide slider boxes)	
BASE MODEL DESCRIPTION	HKANT 23K VANTRAAX® slider suspension system consisting of 48-inch wide slider box with 16-inch ride height suspension, 77.5-inch axle track, HN spindles, 16.5- x 7-inch brakes with Abex 3030-197 brake lining, ABS brackets, QUIK-ALIGN® pivot connection, QUIK-DRAW® pin-pull mechanism and standard Cam Tube System™.	

*System capacity refers to the suspension, axle and slider. Ratings for brakes and wheel-end components differ depending upon options chosen.

AXLE SPREAD (inches)	RIDE HEIGHT (inches)	SYSTEM HEIGHT (inches)	FRONT AXLE LOCATION (inches)	JOUNCE (inches)	REBOUND (inches)	WEIGHT (pounds)
N/A	16	24.25	28.4	2.8	4.5	785
	17	25.25	28.0	2.8	3.5	787

Note: Weight includes 48-inch wide slider, suspension, HN Large-Diameter Axle (LDA™) (5.75-inch) and foundation brake components (body rail weights not included). For a 42-inch wide slider system, deduct 19 pounds. For a 54-inch wide slider system, add 24 pounds. For fixed-pin option, deduct 8 pounds. Does not include box shims.

SPECIFICATIONS

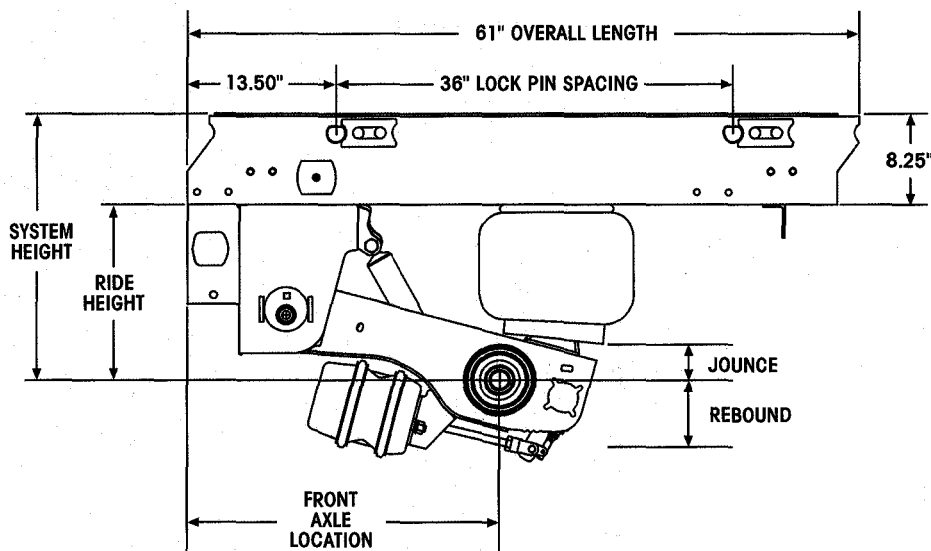



HKANT 40K

SYSTEM CAPACITY*	40,000 lbs. (18 000 kg)
APPLICATION	On-highway
TRAILER TYPES	U.S.A. and Canada: Dry and refrigerated van Mexico, Central and South America: None
AXLE DATA	Diameter: 5.75-inch Large-Diameter Axle (LDA™) Arrangement: Tandem Track: 71.5-, 77.5- and 83.5-inch Spread: 49-inch
FRAME TYPES	Steel only; 96- and 102-inch wide trailers (42-, 48- and 54-inch wide slider boxes)
BASE MODEL DESCRIPTION	HKANT 40K VANTRAAX® slider suspension system consisting of 49-inch spread, 48-inch wide slider box with two 16-inch ride height suspensions, 77.5-inch axle track, HN spindles, 16.5- × 7-inch brakes with Abex 3030-197 brake lining, ABS brackets, QUIK-ALIGN® pivot connection, QUIK-DRAW® pin-pull mechanism and standard Cam Tube System™.

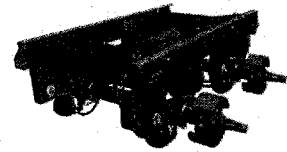

*System capacity refers to the suspensions, axles and slider. Ratings for brakes and wheel-end components differ depending upon options chosen.

AXLE SPREAD (inches)	RISE HEIGHT (inches)	SYSTEM HEIGHT (inches)	FRONT AXLE LOCATION (inches)	JOUNCE (inches)	REBOUND (inches)	WEIGHT (pounds)
49	16	24.25	28.4	2.8	4.5	1,394
	17	25.25	28.0	2.8	3.5	1,398

Note: Weight includes 48-inch wide slider, suspensions, HN Large-Diameter Axles (LDA™) (5.75-inch) and foundation brake components (body rail weights not included). For a 42-inch wide slider system, deduct 33 pounds. For a 54-inch wide slider system, add 33 pounds. For manual pin-pull mechanism, add 13 pounds. Does not include SURELOK® or box shims.

SPECIFICATIONS

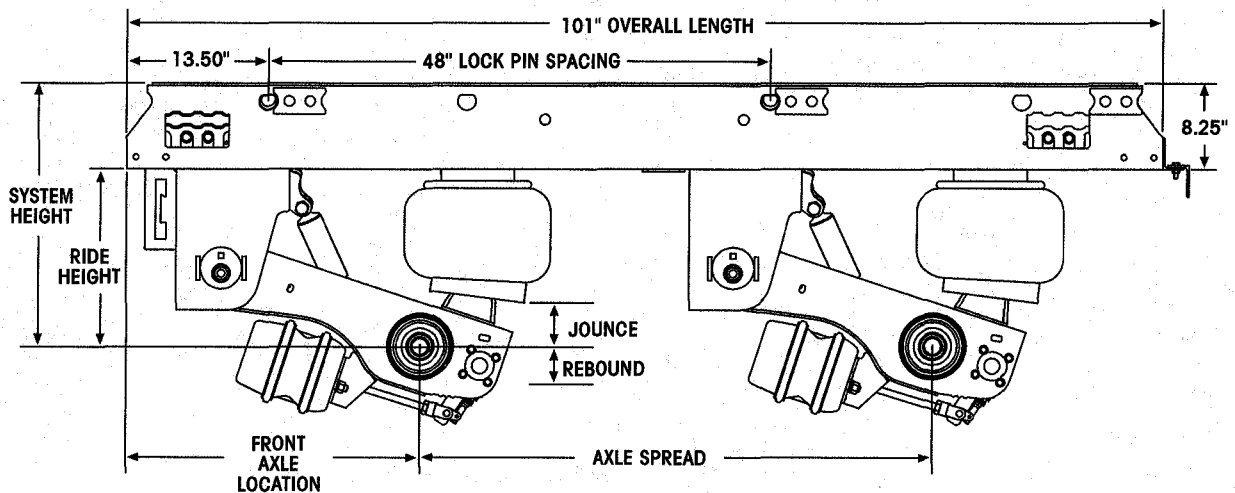

VANTRAA[®] SPECIFICATIONS



HKANT 46K

SYSTEM CAPACITY*	46,000 lbs. (20 700 kg)
APPLICATION	On-highway or maintained roads
TRAILER TYPES	U.S.A. and Canada: Dry, refrigerated and specialty van Mexico, Central and South America: None
AXLE DATA	Diameter: 5.75-inch Large-Diameter Axle (LDA™) Arrangement: Tandem Track: 71.5-, 77.5- and 83.5-inch Spread: 49-inch
FRAME TYPES	Steel only; 96- and 102-inch wide trailers (42-, 48- and 54-inch wide slider boxes)
BASE MODEL DESCRIPTION	HKANT 46K VANTRAA [®] slider suspension system consisting of 49-inch spread, 48-inch wide slider box with two 16-inch ride height suspensions, 77.5-inch axle track, HN spindles, 16.5- x 7-inch brakes with Abex 3030-197 brake lining, ABS brackets, QUIK-ALIGN [®] pivot connection, QUIK-DRAW [®] pin-pull mechanism and standard Cam Tube System™.

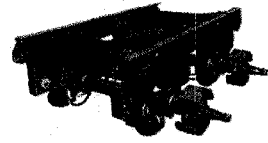

*System capacity refers to the suspensions, axles and slider. Ratings for brakes and wheel-end components differ depending upon options chosen.

AXLE SPREAD (inches)	RISE HEIGHT (Inches)	SYSTEM HEIGHT (inches)	FRONT AXLE LOCATION (inches)	JOUNCE (inches)	REBOUND (inches)	WEIGHT (pounds)
49	16	24.25	28.4	2.8	5.5	1,405
	17	25.25	28.0	2.8	4.5	1,409

Note: Weight includes 48-inch wide slider, suspensions, HN Large-Diameter Axles (LDA™) (5.75-inch) and foundation brake components (body rail weights not included). For a 42-inch wide slider system, deduct 33 pounds. For a 54-inch wide slider system, add 33 pounds. For manual pin-pull mechanism, add 13 pounds. Does not include SURELOK[®] or box shims.

SPECIFICATIONS

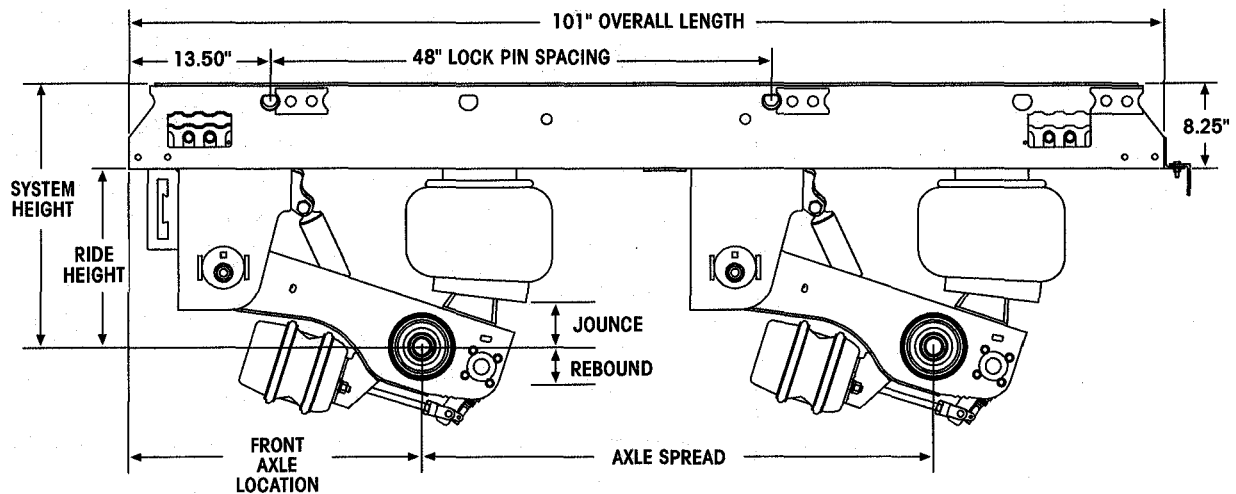



HKANT 46K — 121-inch Spread

SYSTEM CAPACITY*	46,000 lbs. (20 700 kg)
APPLICATION	On-highway or maintained roads
TRAILER TYPES	U.S.A. and Canada: Dry, refrigerated and specialty van Mexico, Central and South America: None
AXLE DATA	Diameter: 5.75-inch Large-Diameter Axle (LDA™) Arrangement: Tandem Track: 77.5- and 83.5-inch Spread: 121-inch
FRAME TYPES	Steel only; 102-inch wide trailers (48- and 54-inch wide slider boxes)
BASE MODEL DESCRIPTION	HKANT 46K widespread VANTRAAX® slider suspension system consisting of 121-inch spread, 48-inch wide slider box with two 16-inch ride height suspensions, 77.5-inch axle track, HN spindles, 16.5- x 7-inch brakes with Abex 3030-197 brake lining, ABS brackets, QUIK-ALIGN® pivot connection, QUIK-DRAW® pin-pull mechanism and standard Cam Tube System™.

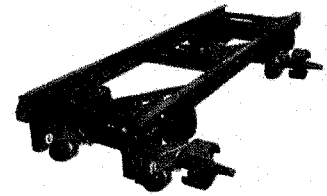

*System capacity refers to the suspensions, axles and slider. Ratings for brakes and wheel-end components differ depending upon options chosen.

AXLE SPREAD (inches)	RISE HEIGHT (inches)	SYSTEM HEIGHT (inches)	FRONT AXLE LOCATION (inches)	JOUNCE (inches)	REBOUND (inches)	WEIGHT (pounds)
121	16	24.25	28.4	2.8	4.5	1,652
	17	25.25	28.0	2.8	3.5	1,656

Note: Weight includes 48-inch wide slider, suspensions, HN Large-Diameter Axles (LDA™) (5.75-inch) and foundation brake components (body rail weights not included). For a 54-inch wide slider system, add 45 pounds. For fixed-pin option, deduct 9 pounds. Does not include SURELOK® or box shims.

SPECIFICATIONS

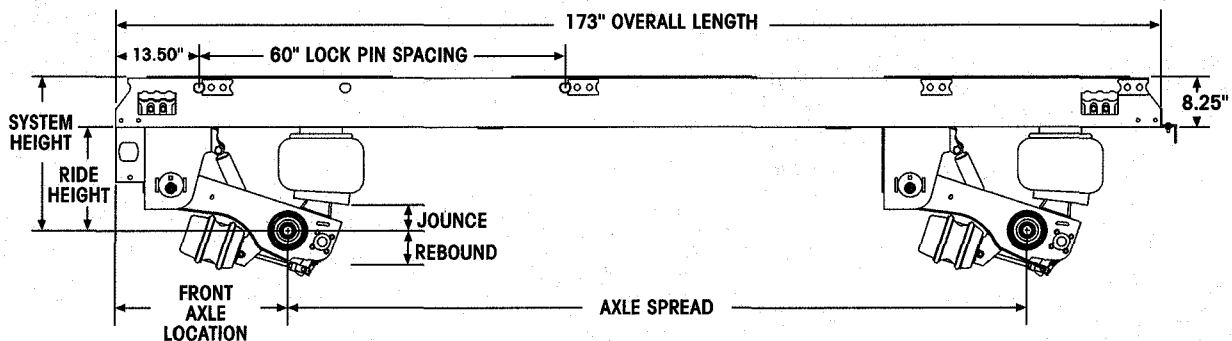

VANTRAAX® SPECIFICATIONS



HKAT 50K

SYSTEM CAPACITY*	50,000 lbs. (22 500 kg)	
APPLICATION	On-highway or maintained roads "domiciled in Mexico"	
TRAILER TYPES	U.S.A. and Canada: Dry, refrigerated and specialty van Mexico, Central and South America: Dry, refrigerated and specialty van	
AXLE DATA	Diameter: 5.75-inch Large-Diameter Axle (LDA™) Arrangement: Tandem Track: 71.5- and 77.5-inch Spread: 49-inch	
FRAME TYPES	Steel only; 96- and 102-inch wide trailers (42- and 48-inch wide slider boxes)	
BASE MODEL DESCRIPTION	HKAT 50K VANTRAAX® slider suspension system consisting of 49-inch spread, 48-inch wide slider box with two 16-inch ride height suspensions, 77.5-inch axle track, HN spindles, 16.5- x 7-inch brakes with Abex 3030-197 brake lining, ABS brackets, QUIK-ALIGN® pivot connection, QUIK-DRAW® pin-pull mechanism and standard Cam Tube System™.	

*System capacity refers to the suspensions, axles and slider. Ratings for brakes and wheel-end components differ depending upon options chosen.

AXLE SPREAD (inches)	RISE HEIGHT (inches)	SYSTEM HEIGHT (inches)	FRONT AXLE LOCATION (inches)	JOUNCE (inches)	REBOUND (inches)	WEIGHT (pounds)
49	16	24.25	28.4	3.1	4.6	1,579
	17	25.25	28.0	3.3	3.6	1,584

Note: Weight includes 48-inch wide slider, suspensions, HN Large-Diameter Axles (LDA™) (5.75-inch) and foundation brake components (body rail weights not included). For a 42-inch wide slider system, deduct 41 pounds. For manual pin-pull mechanism, add 15 pounds. For fixed-pin option, deduct 21 pounds. Does not include SURELOK® or box shims.

SPECIFICATIONS

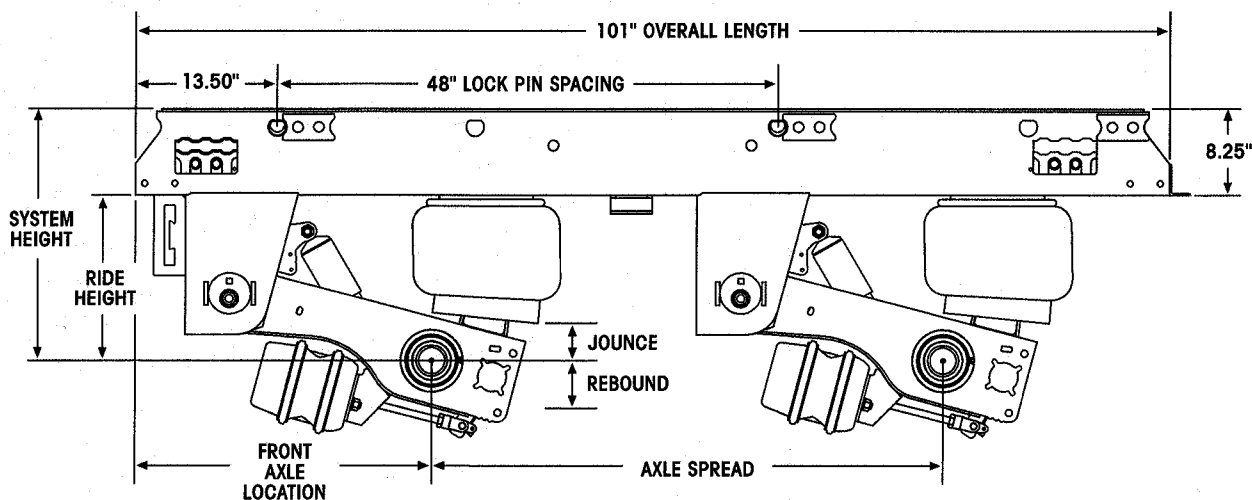



HKANT 69K23

SYSTEM CAPACITY*	69,000 lbs. (31 200 kg)
APPLICATION	On-highway or maintained roads
TRAILER TYPES	U.S.A. and Canada: Dry, refrigerated and specialty van Mexico, Central and South America: None
AXLE DATA	Diameter: 5.75-inch Large-Diameter Axle (LDA™) Capacity: 23,000 lbs. (10 400 kg) Arrangement: Tridem Track: 77.5- and 83.5-inch Spread: 49-, 60- and 72-inch
FRAME TYPES	Steel only; 96- and 102-inch wide trailers (48- and 54-inch wide slider boxes)
BASE MODEL DESCRIPTION	HKANT 69K23 VANTRAAX® slider suspension system consisting of 72-inch spread, 48-inch wide slider box with three 16-inch ride height suspensions, 77.5-inch axle track, HP spindles, 16.5- x 7-inch brakes with Abex 3030-197 brake lining, ABS brackets, QUIK-ALIGN® pivot connection, QUIK-DRAW® pin-pull mechanism and standard Cam Tube System™.

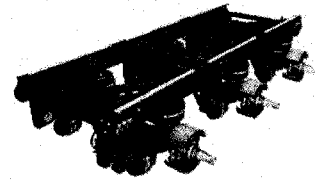

*System capacity refers to the suspensions, axles and slider. Ratings for brakes and wheel-end components differ depending upon options chosen.

AXLE SPREAD (inches)	RISE HEIGHT (inches)	SYSTEM HEIGHT (inches)	FRONT AXLE LOCATION (inches)	JOUNCE (inches)	REBOUND (inches)	WEIGHT (pounds)
60	16	24.25	28.4	2.8	4.7	2,188
	17	25.25	28.0	3.0	3.7	2,195
72	16	24.25	28.4	2.8	4.7	2,236
	17	25.25	28.0	3.0	3.7	2,242
49	16	24.25	28.4	2.8	4.7	2,143
	17	25.25	28.0	3.0	3.7	2,149

Note: Weight includes 48-inch wide slider, suspensions, HN Large-Diameter Axles (LDA™) (5.75-inch) and foundation brake components (body rail weights not included). For a 42-inch wide slider system, deduct 59 pounds. For a 54-inch wide slider system, add 61 pounds. For manual pin-pull mechanism, add 18 pounds for the 72-inch spread model and 14 pounds for the 60-inch spread model. For fixed-pin option, deduct 24 pounds for the 72-inch spread model and 26 pounds for the 60-inch spread model. Does not include SURELOK® or box shims.

SPECIFICATIONS

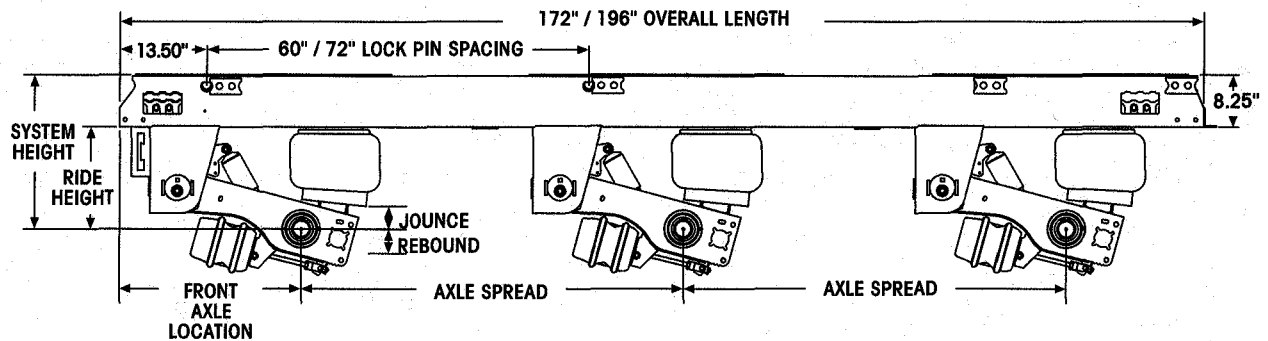

VANTRAAX® SPECIFICATIONS



HKAT 69K25

SYSTEM CAPACITY*	69,000 lbs. (31 200 kg)
APPLICATION	On-highway or maintained roads
TRAILER TYPES	U.S.A. and Canada: Dry, refrigerated and specialty van Mexico, Central and South America: None
AXLE DATA	Diameter: 5.75-inch Large-Diameter Axle (LDA™) Capacity: 25,000 lbs. (11 300 kg) Arrangement: Tridem Track: 71.5-, 77.5- and 83.5-inch Spread: 60- and 72-inch
FRAME TYPES	Steel only; 96- and 102-inch wide trailers (42-, 48- and 54-inch wide slider boxes)
BASE MODEL DESCRIPTION	HKAT 69K25 VANTRAAX® slider suspension system consisting of 72-inch spread, 48-inch wide slider box with three 16-inch ride height suspensions, 77.5-inch axle track, HN spindles, 16.5- x 7-inch brakes with Abex 3030-197 brake lining, ABS brackets, QUIK-ALIGN® pivot connection, QUIK-DRAW® pin-pull mechanism and standard Cam Tube System™.

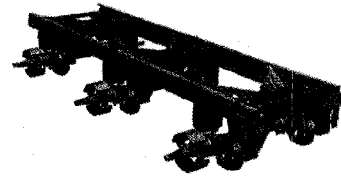

*System capacity refers to the suspensions, axles and slider. Ratings for brakes and wheel-end components differ depending upon options chosen.

AXLE SPREAD (inches)	RIDE HEIGHT (inches)	SYSTEM HEIGHT (inches)	FRONT AXLE LOCATION (inches)	JOUNCE (inches)	REBOUND (inches)	WEIGHT (pounds)
60	16	24.25	28.4	3.1	4.6	2,420
	17	25.25	28.0	3.0	3.6	2,427
72	16	24.25	28.4	3.1	4.6	2,479
	17	25.25	28.0	3.0	3.6	2,486

Note: Weight includes 48-inch wide slider, suspensions, HN Large-Diameter Axles (LDA™) (5.75-inch) and foundation brake components (body rail weights not included). For a 42-inch wide slider system, deduct 66 pounds. For a 54-inch wide slider system, add 68 pounds. For manual pin-pull mechanism, add 18 pounds for the 72-inch spread model and 14 pounds for the 60-inch model. For fixed-pin option, deduct 24 pounds for the 72-inch spread model and 26 pounds for the 60-inch spread model. Does not include SURELOK® or box shims.

SPECIFICATIONS

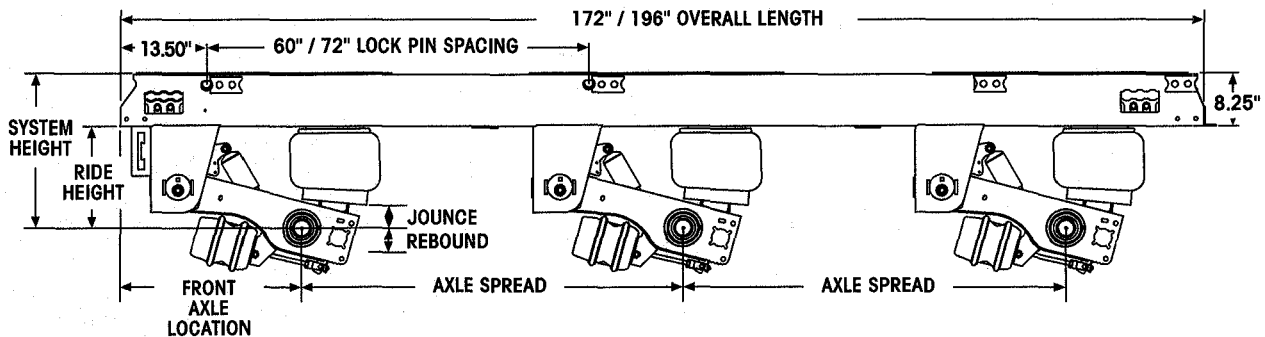



HKARL 46K

SYSTEM CAPACITY*	46,000 lbs. (20 700 kg)
APPLICATION	On-highway or maintained roads
TRAILER TYPES	U.S.A. and Canada: Dry, refrigerated and specialty van Mexico, Central and South America: None
AXLE DATA	Diameter: 5.75-inch Large-Diameter Axle (LDA™) Arrangement: Tandem Track: 77.5-inch Spread: 49-inch
FRAME TYPES	Steel only; 102-inch wide trailers (48-inch wide slider box)
BASE MODEL DESCRIPTION	HKARL 46K VANTRAAX® slider suspension system consisting of 48-inch wide slider box with 10- or 11-inch ride height suspension, 77.5-inch axle track, HN spindles, 16.5- x 7-inch brakes with Abex 3030-197 brake lining, ABS brackets, QUIK-ALIGN® pivot connection, QUIK-DRAW® pin-pull mechanism and standard Cam Tube System™.

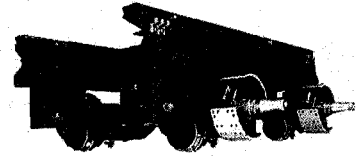

*System capacity refers to the suspension, axle and slider. Ratings for brakes and wheel-end components differ depending upon options chosen.

AXLE SPREAD (inches)	RIDE HEIGHT (inches)	SYSTEM HEIGHT (inches)	FRONT AXLE LOCATION (inches)	JOUNCE (inches)	REBOUND (inches)	WEIGHT (pounds)
49	10	24.25	28.5	3.3	4.8	1,840
	11	25.25	28.5	3.4	4.2	1,856

Note: Weight includes 48-inch wide slider, suspensions, HN 5-inch axles and foundation brake components (body rail weights not included). 42-inch wide slider system not available. For manual pin-pull mechanism, add 14 pounds. For fixed-pin option, deduct 8 pounds. Does not include box shims.

SPECIFICATIONS

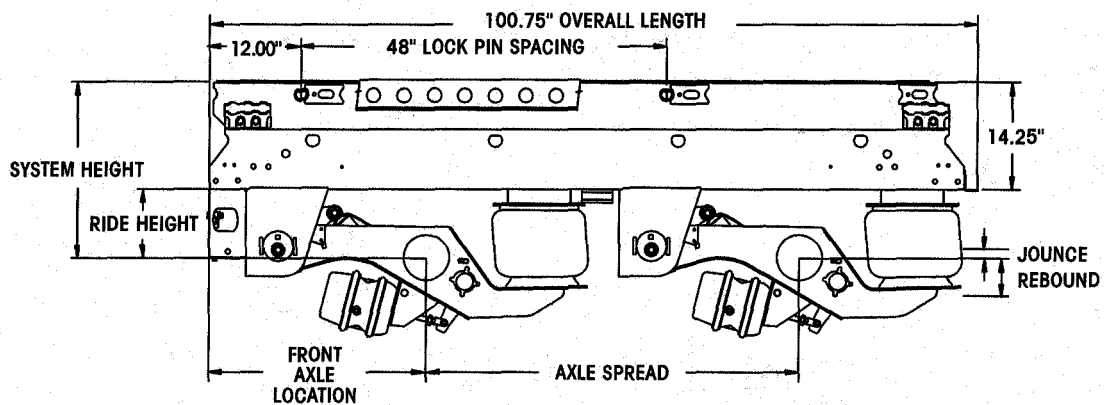



BRAKE OPTIONS

For complete details on the wide range of brake options available including lining choices, brake ratings and FMVSS/CMVSS 121 brake certifications, refer to publication *L809, Brake Specifications*. Air disc brake packages available on VANTRAAX HKANT models. Please contact Hendrickson for assistance.

BRAKE CHAMBERS

Industry standard brake chambers with pushrod length of 9.75-inches and clamping / port orientation of zero degrees are compatible.

BRAKE ADJUSTERS

Industry standard 5.5- and 6-inch brake adjusters are compatible.

READY-TO-ROLL® (RTR®)

Choose from a broad mix of offerings to customize running gear for your specific application. Wheel-end options consist of aluminum, ductile iron or ADI in a variety of standard and extended service packages.

HEIGHT CONTROL VALVES

For complete details on available height control valve kits, refer to publication *L575, Height Control Valve Application Table*.

OPTIONS

SLIDER PIN EXTRACTOR

QUIK-DRAW® — fully pneumatic, pin-pull mechanism

Fixed-pin option — slider pins only for fixed van applications

SURELOK®

Dock height lock that maintains trailer at deck height while minimizing trailer walk during loading and unloading

DUST SHIELD

Clamp-on dust shield provides protection for both drum and air disc brakes — factory or OEM installed

WELD-ON AIR TANK BRACKETS

Bracket kits available for customer installation; use with industry standard jumbo or small tanks

Factory installed brackets available from Hendrickson; use with industry standard jumbo tanks

MANUAL STOP BAR

Efficiently assists the driver in slider box repositioning

STINGER

Bolt-on bracket available in 32- or 36-inch lengths — road and curbside mounting ready

MUD FLAP MOUNTING ANGLE

Bolt-on bracket, attaches to rear cross member

FACTORY PRE-ALIGNED SLIDERS

Ensures accurate parallelism between two neutral-toe axles

SOFT COAT FINISH

Provides superior protection against rust and corrosion

RAMP-READY (HKARL 46K)

Eliminates need for heavy, expensive spacer tubes with built-in 30-inch by 6.5-inch ramp bay — 10- and 11-inch ride heights

LOW-RIDE (HKAL 46K)*

Ideal for low-ride height applications — 10- and 11-inch ride heights

** Please contact your Hendrickson customer service representative for component information.*

www.hendrickson-intl.com



Hendrickson Canada
250 Chrysler Drive, Unit #3
Brampton, ON Canada L6S 6B6
905.789.1030
Fax 905.789.1033

Trailer Commercial Vehicle Systems
2070 Industrial Place SE
Canton, OH 44707-2641 USA

866.RIDEAIR (743.3247)
330.489.0045
Fax 800.696.4416

Hendrickson Mexicana
Circuito El Marqués Sur #29
Parque Industrial El Marqués
Pob. El Colorado, Municipio El Marqués,
Querétaro, México C.P. 76246
+52 (442) 296.3600
Fax: +52 (442) 296.3601