

Interior A-Pillar Trim Deformation

Service Category Vehicle Interior

Section Interior Panels/Trim

Market USA

Toyota Supports
ASE Certification 

Applicability

YEAR(S)	MODEL(S)	ADDITIONAL INFORMATION
2012 – 2013	Camry, Camry HV	

Introduction

Some 2012 – 2013 model year Camry and Camry HV vehicles may exhibit a bowing or deformation of the interior A-Pillar trim along the windshield. Use the following procedure to replace the interior A-Pillar trim garnish and address this condition.

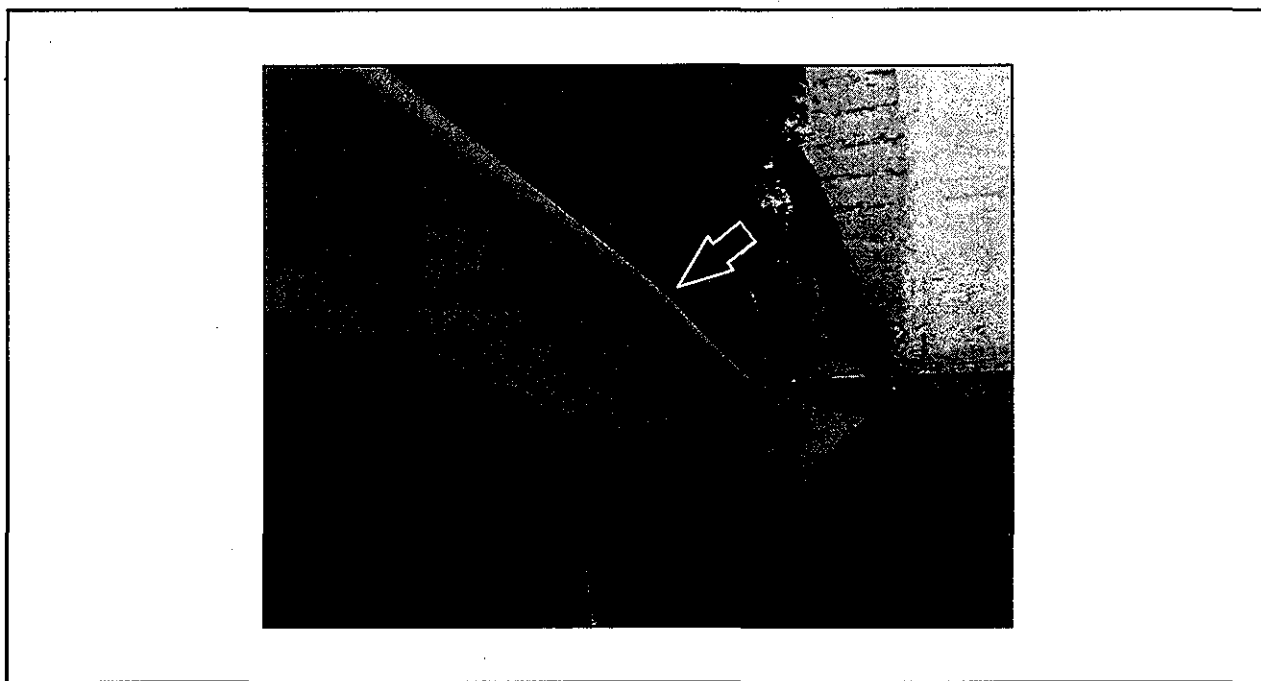

Interior A-Pillar Trim Deformation

Production Change Information

This bulletin applies to vehicles produced **BEFORE** the Production Change Effective VINs shown below.

MODEL	DRIVETRAIN	PLANT	PRODUCTION CHANGE EFFECTIVE VIN
Camry	4 Cylinder	TMMK Line 1	4T1BF1FK#DU212235
		TMMK Line 2	4T1BF1FK#DU643066
		SIA	4T4BF1FK#DR280061
	V6	TMMK Line 1	4T1BK1FK#DU020454
		TMMK Line 2	4T1BK1FK#DU525611
Camry HV	HV	TMMK Line 2	4T1BD1FK#DU066529

Parts Information

PART NUMBER		PART NAME	QTY
PREVIOUS	NEW		
62220-06190-A0	62220-06191-A0	Garnish Assy, Fr Pillar, LH	1
62220-06190-B0	62220-06191-B0		
62210-06190-A0	62210-06191-A0	Garnish Assy, Fr Pillar, RH	1
62210-06190-B0	62210-06191-B0		

Warranty Information

OP CODE	DESCRIPTION	TIME	OFF	T1	T2
BD1216	R & R Body Pillar or Roof Side Pillar Garnish Assembly	0.2	62220-06190-A0 62220-06190-B0	67	13
Combo A	Other Side	0.2	62210-06190-A0 62210-06190-B0		

APPLICABLE WARRANTY

- This repair is covered under the Toyota Comprehensive Warranty. This warranty is in effect for 36 months or 36,000 miles, whichever occurs first, from the vehicle's in-service date.
- Warranty application is limited to occurrence of the specified condition described in this bulletin.

4 of 7

n Deformation

Procedure

1. Remove the front pillar garnish.
 - A. Pull the upper part of the garnish toward the inside of the cabin and disengage the garnish from the base of the 2 clips.

HINT

Make the front pillar garnish hang down from the front pillar garnish clip.

Figure 1.

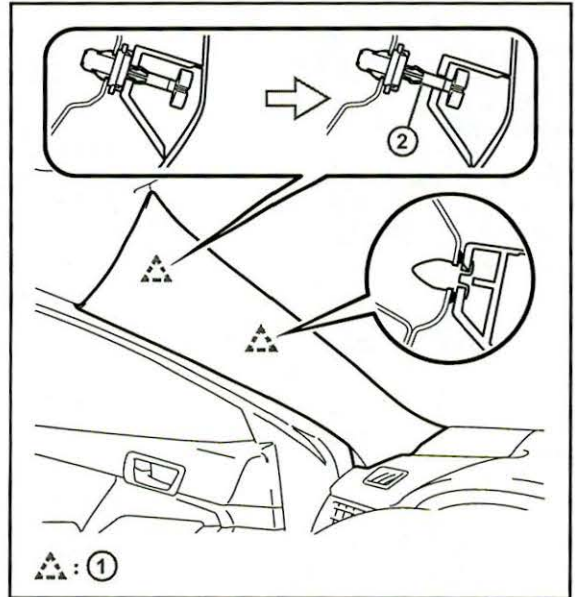

1	Clip
2	Front Pillar Garnish Clip

Interior A-Pillar Trim Deformation

Repair Procedure (Continued)

- B. While pushing the tabs on the front pillar garnish clip in the direction indicated by the arrow (A) shown in Figure 2, disengage the front pillar garnish clip.

Figure 2.

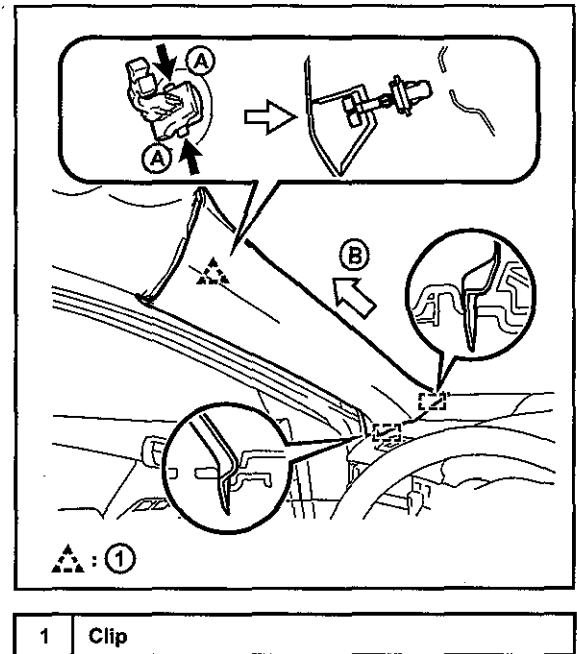

- C. Pull the garnish in the direction indicated by the arrow (B) shown in Figure 2 to disengage the 2 guides and remove the front pillar garnish.

Interior A-Pillar Trim Deformation

Repair Procedure (Continued)

D. Protect the curtain shield airbag assembly.

Cover the airbag with a piece of cloth or nylon and secure the edges of the cover with tape.

CAUTION

Cover the curtain shield airbag with a protective cover as soon as the front pillar garnish is removed.

Figure 3.

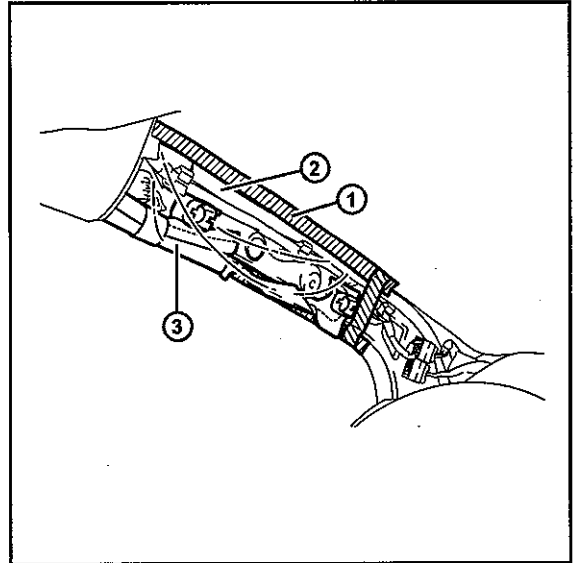

1	Adhesive Tape
2	Protective Cover
3	Curtain Shield Airbag Assembly

Interior A-Pillar Trim Deformation

Repair Procedure (Continued)

2. Install the NEW front pillar garnish.
 - A. Remove the protective cover.
 - B. Install the NEW front pillar garnish clip to front pillar garnish.

HINT
Install the front pillar garnish clip so that it faces as shown in Figure 4.

NOTE
Do NOT use an old pillar garnish clip.

Figure 4.

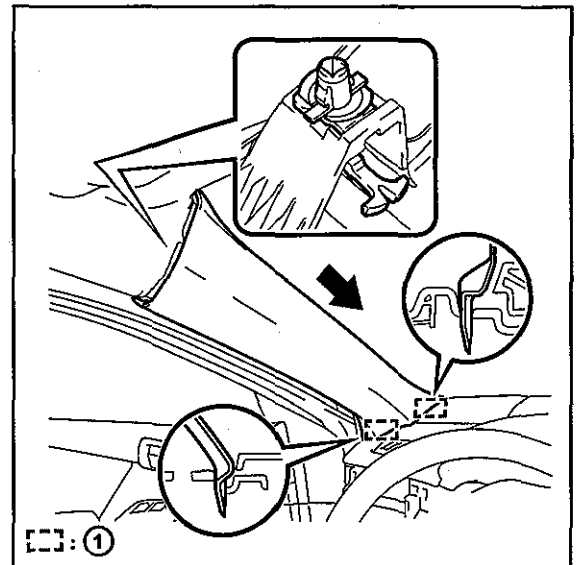

1 Guide

- C. Engage the 2 guides as shown in Figure 4.

Interior A-Pillar Trim Deformation

Repair Procedure (Continued)

- D. Engage the 2 clips to install the front pillar garnish.

Figure 5.

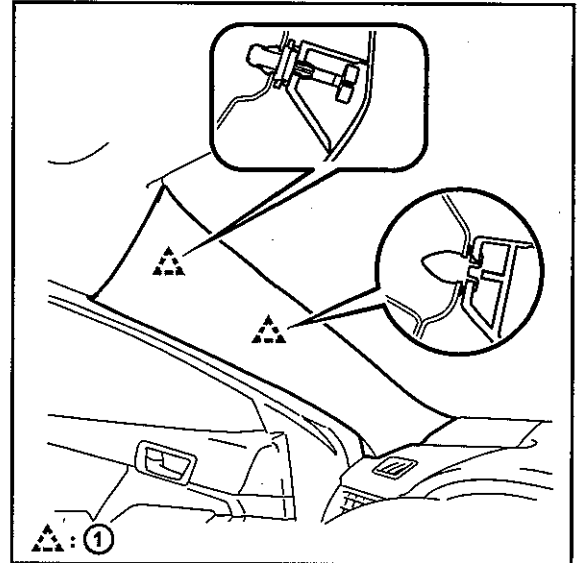

1	Clip
---	------