

Sunvisor Mount Reinforcement Bracket Kit Installation

Service Category Vehicle Interior

Section Interior Panels/Trim

Market USA

Toyota Supports
 ASE Certification 

Applicability

YEAR(S)	MODEL(S)	ADDITIONAL INFORMATION
2007 – 2011	Camry, Camry HV	

SUPERSESION NOTICE

The information contained in this bulletin supersedes SB No. T-SB-0284-09.

- The Title, Introduction, Warranty Information, Parts Information, and Figure 19 in the Repair Procedure have been updated.

Service Bulletin No. T-SB-0284-09 is Obsolete and any printed versions should be discarded. Be sure to review the entire content of this bulletin before proceeding.

Introduction

The purpose of this bulletin is to provide a procedure to repair the sunvisor mount after improper installation/removal or if the sunvisors are operated forcefully resulting in the sheet metal at the mounting area being damaged. If this has occurred, the sunvisor base located on the headliner may become loose. To address this, a newly designed mounting bracket has been developed to address this condition. Use the following repair procedures to install the new mounting brackets.

NOTE

- This bulletin does NOT provide sunvisor removal and installation procedures. Please refer to T-SB-0093-09 "*Sunvisor - Removal & Installation Procedures*" for proper removal and installation procedures.
- If the sunvisor slowly rotates downward and/or doesn't hold position, this bulletin does NOT apply.

Sunvisor Mount Reinforcement Bracket Kit Installation

Introduction (Continued)

Figure 1.

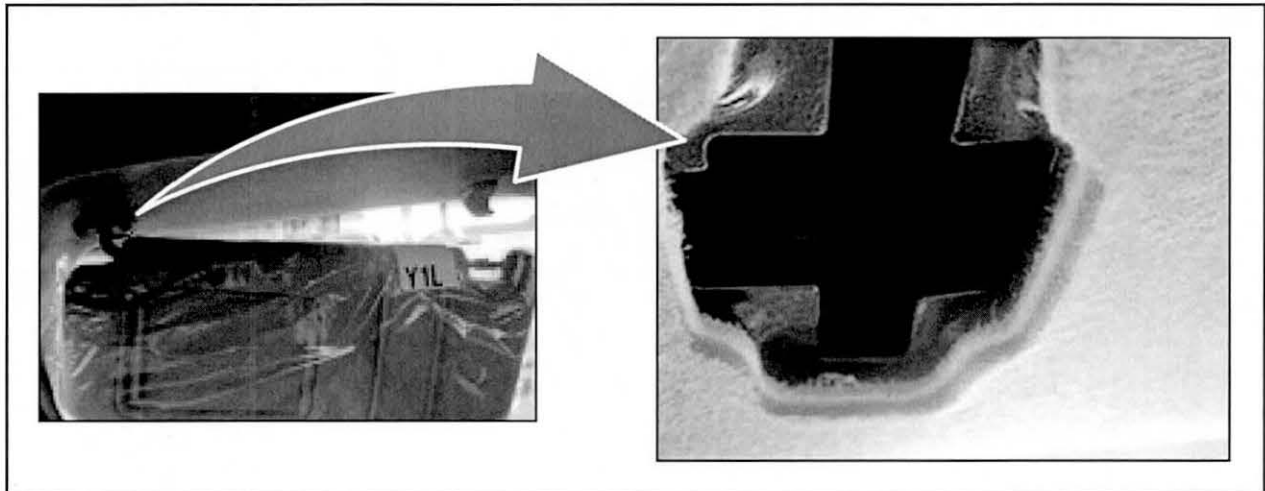

Warranty Information

OP CODE	DESCRIPTION	TIME	OFP	T1	T2
BD9048	Visor Bracket Kit Installation	0.4	743#0-#####	62	13

NOTE

Confirm the OFP matches the vehicle's VIN in the EPC before filing the warranty claim.

APPLICABLE WARRANTY

- This repair is covered under the Toyota Basic Warranty. This warranty is in effect for 36 months or 36,000 miles, whichever occurs first, from the vehicle's in-service date.
- Warranty application is limited to occurrence of the specified condition described in this bulletin.

Parts Information

PREVIOUS PART NUMBER	CURRENT PART NUMBER	PART NAME	COLOR	QTY
N/A	04009-04133	Bracket Kit, Visor Repair, RH	Gray	1
N/A	04009-04233		Tan	
N/A	04009-04333	Bracket Kit, Visor Repair, LH	Gray	
N/A	04009-04433		Tan	
N/A	08231-00801	Noise Kit	N/A	

Sunvisor Mount Reinforcement Bracket Kit Installation

Required Tools & Equipment

TOOLS AND MATERIAL	QTY
String or Wire (approximately 12 in. or 30 cm)	1

Inspection Procedure

1. Rotate the sunvisor assembly to the vertical position.
2. Remove the sunvisor from the retention clip.
3. Measure the distance between the bottom of the retention clip to the top of the sunvisor retention bar.

Figure 2.



4. If the distance is greater than 13 mm (0.5 in.) proceed with the repair procedure in this bulletin.

Repair Procedure

With Sunvisor Vanity Light

1. Remove the affected sunvisor assembly per instructions in [T-SB-0093-09](#).
2. Inspect the sunvisor base for any damage.

NOTE
 If the sunvisor base is damaged, replace the sunvisor and then proceed with the repair procedure.

Figure 3.

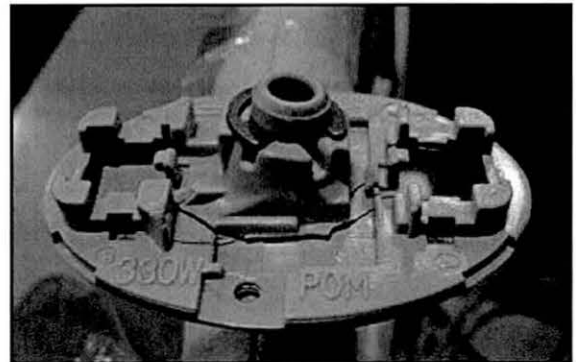

Sunvisor Mount Reinforcement Bracket Kit Installation

Repair Procedure

With Sunvisor Vanity Light (Continued)

3. Straighten the roof sheet metal where the visor clips contact the roof.

Figure 4.

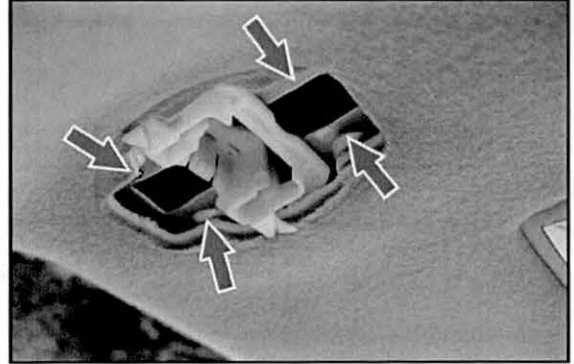

4. Remove the 2 plastic reinforcements from the top surface of the headliner.

Figure 5.

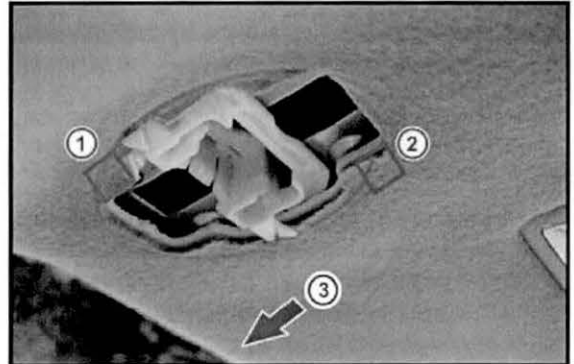

NOTE

Plastic reinforcements are located on the RH rear and LH front corners of headliner opening for both the LH and RH visor assembly.

1	LH – Front Corner
2	RH – Rear Corner
3	Front

Sunvisor Mount Reinforcement Bracket Kit Installation

Repair Procedure

With Sunvisor Vanity Light (Continued)

5. Apply felt to the roof panel opening for visor as shown.

From the Noise Kit, cut 2 felt strips of the following dimensions:

Length: 25 mm (1 in.)

Width: 9 mm (3/8 in.)

Thickness: 0.5 mm (0.02 in.) thinnest felt sheet material in the kit

Figure 6.

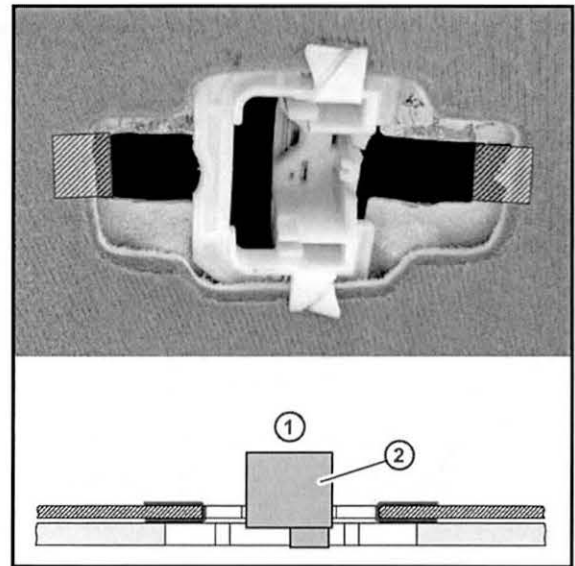

1	Cross Section
2	Connector

6. Install the front visor support.

NOTE

Front and rear supports are identical.

- A. Thread string or thin wire through the opening of the support.

Figure 7.

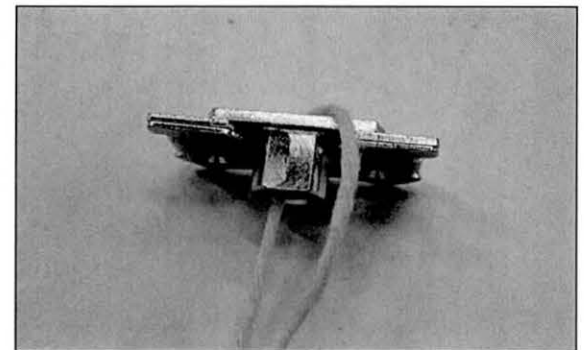

Sunvisor Mount Reinforcement Bracket Kit Installation

Repair Procedure

With Sunvisor Vanity Light (Continued)

- B. Insert the support into the roof panel opening and attach the support hook to the front edge of the roof panel opening.

NOTE

- Hold the string or wire ends when installing to prevent the support from falling into the body.
- Move the connector toward the rear of the vehicle to widen the opening.

Figure 8.

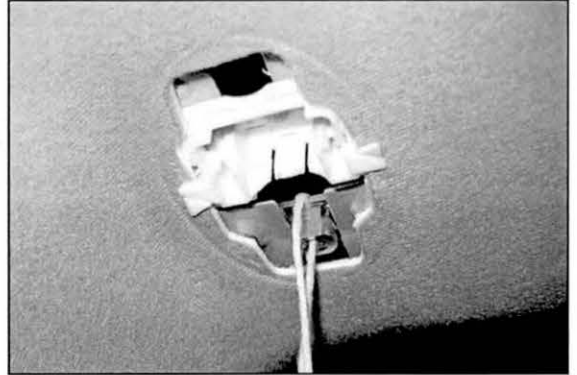

- C. Attach felt between the support and the roof panel to hold the support in place.

From the Noise Kit, cut 2 felt strips of the following dimensions:

Length: 25 mm (1 in.)

Width: 5 mm (3/16 in.)

Thickness: 0.5 mm (0.02 in.)

Figure 9.

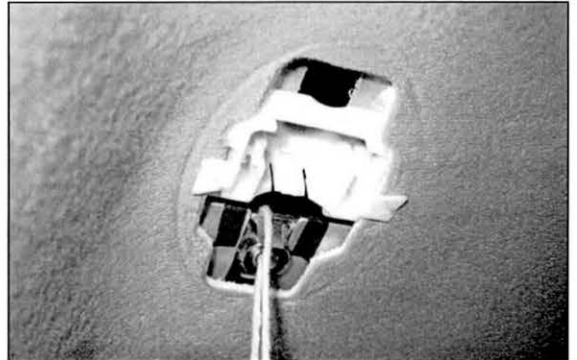

- D. Remove the string or wire from the support.

Sunvisor Mount Reinforcement Bracket Kit Installation

Repair Procedure

With Sunvisor Vanity Light (Continued)

7. Install the rear visor support.

A. Thread string or thin wire through the opening of the support.

Figure 10.

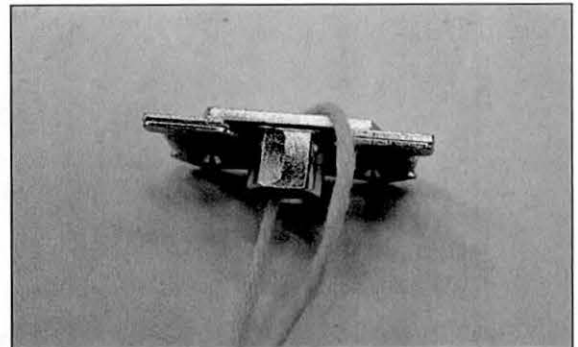

B. Insert the support through the connector opening and attach the support hook to the edge of the roof panel opening.

Figure 11.

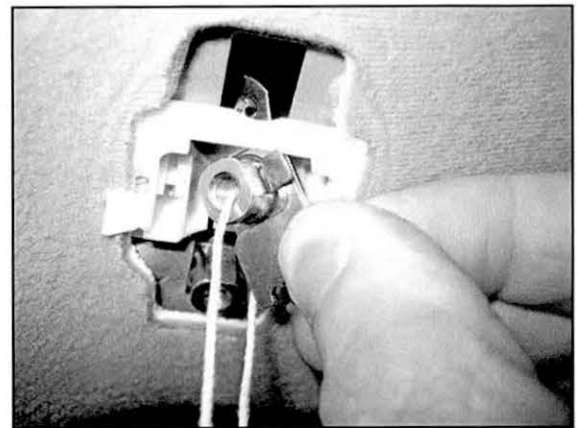

Sunvisor Mount Reinforcement Bracket Kit Installation

Repair Procedure

With Sunvisor Vanity Light (Continued)

- C. Reposition the string or wire as indicated in Figure 12.

Figure 12.

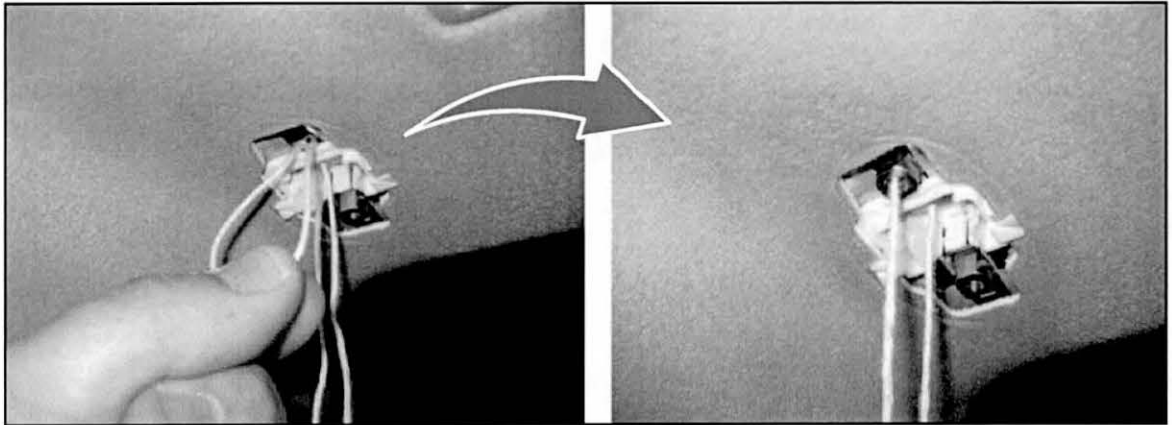

- D. Attach felt between the support and the roof panel to hold the support in place.

From the Noise Kit, cut 2 felt strips of the following dimensions:

Length: 25 mm (1 in.)

Width: 5 mm (3/16 in.)

Thickness: 0.5 mm (0.02 in.)

Figure 13.

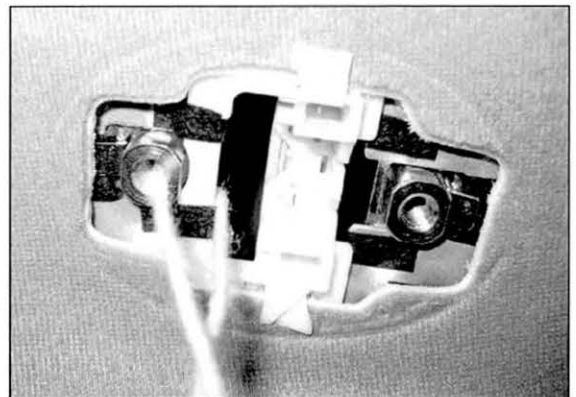

- E. Remove the string or wire from the support.

Sunvisor Mount Reinforcement Bracket Kit Installation

Repair Procedure

With Sunvisor Vanity Light (Continued)

8. Install the brackets into the sunvisor base.
 - A. Remove the clips remaining in the visor.
 - B. Insert 2 brackets into the visor base.

NOTE

- If brackets are loose and fall out easily, install tape to temporarily hold the brackets in position.
- If the brackets are tight, use a clamp or other device to secure the brackets flush to visor base.

Figure 14.

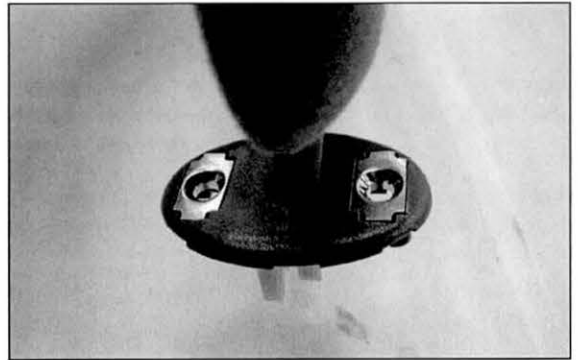

9. Install the sunvisor assembly.
 - A. Insert the visor base partially into the roof opening.
 - B. Install 2 screws into the visor support.
Torque: 3.0 N*m (30 kgf*cm, 2.21 ft*lbf)

NOTE

- Do NOT push the screw into the support. This could cause the support to come loose.
- Remove the tape from the brackets if used in step 8B.

Figure 15.

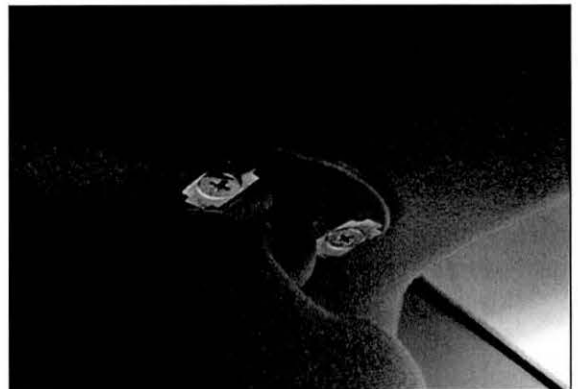

Sunvisor Mount Reinforcement Bracket Kit Installation

Repair Procedure

With Sunvisor Vanity Light (Continued)

10. Install the cover from the Visor Repair Bracket Kit. Figure 16.

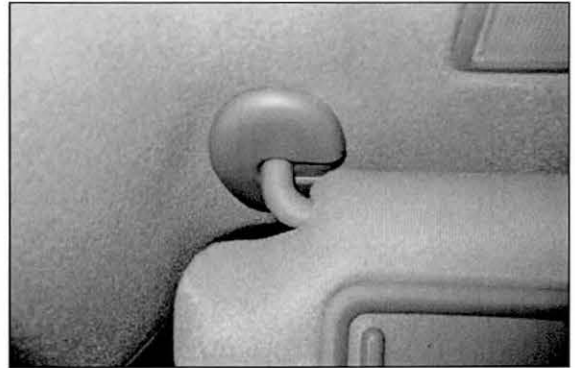

Without Sunvisor Vanity Light

1. Remove the affected sunvisor assembly per instructions in [T-SB-0093-09](#).
2. Inspect the sunvisor base for any damage.

NOTE

If the sunvisor base is damaged, replace the sunvisor and then proceed with the repair procedure.

Figure 17.

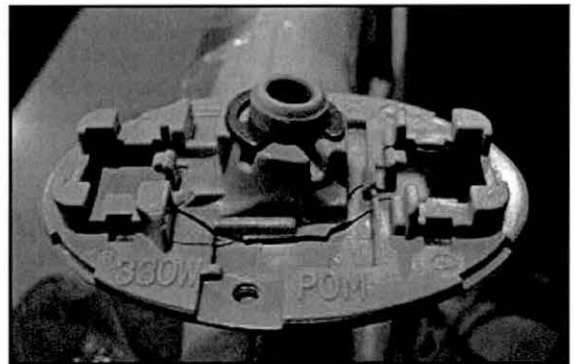

Sunvisor Mount Reinforcement Bracket Kit Installation

Repair Procedure

Without Sunvisor Vanity Light (Continued)

3. Straighten the roof sheet metal where the visor clips contact the roof.

Figure 18.

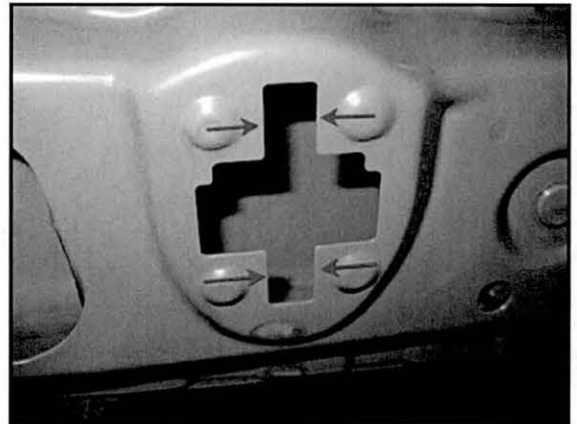

4. Remove the 2 plastic reinforcements from the top surface of the headliner.

Figure 19.

NOTE

Plastic reinforcements are located on the RH rear and LH front corners of headliner opening for both the LH and RH visor assembly.

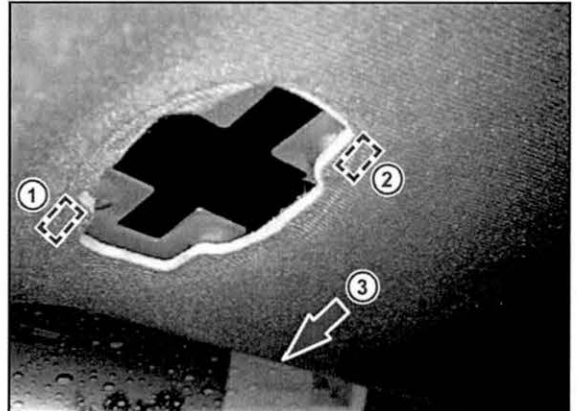

1	LH – Front Corner
2	RH – Rear Corner
3	Front

Sunvisor Mount Reinforcement Bracket Kit Installation

Repair Procedure

Without Sunvisor Vanity Light (Continued)

5. Apply felt to the roof panel opening for visor as shown.

From the Noise Kit, cut 2 felt strips of the following dimensions:

Length: 25 mm (1 in.)

Width: 9 mm (3/8 in.)

Thickness: 0.5 mm (0.02 in.) thinnest felt sheet material in the kit

Figure 20.

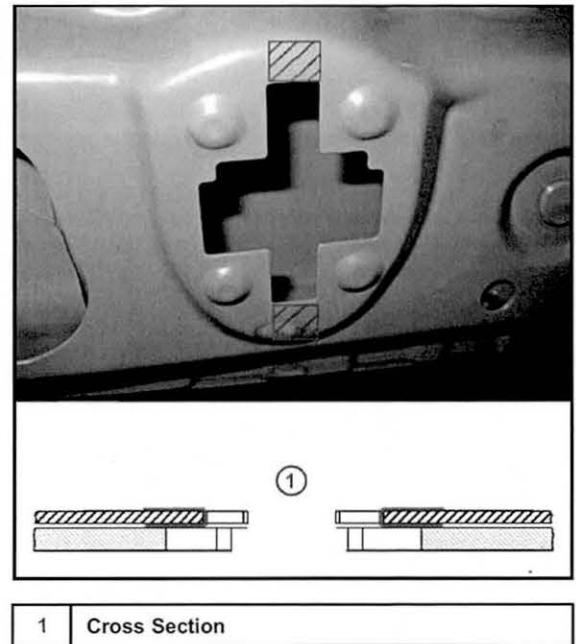

6. Install the front visor support.

NOTE

Front and rear supports are identical.

- A. Thread string or thin wire through the opening of the support.

Figure 21.

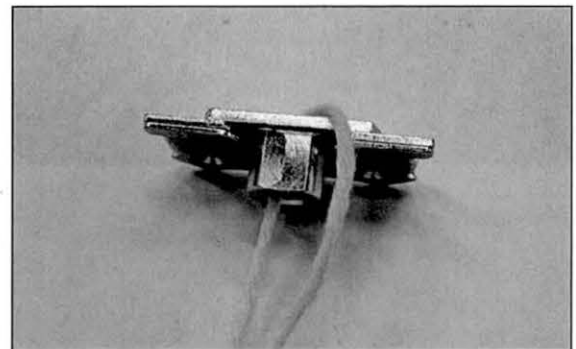

Sunvisor Mount Reinforcement Bracket Kit Installation

Repair Procedure

Without Sunvisor Vanity Light (Continued)

- B. Insert the support into the roof panel opening and attach the support hook to the front edge of the roof panel opening.

NOTE

Hold string or wire ends when installing to prevent support from falling into the body.

Figure 22.

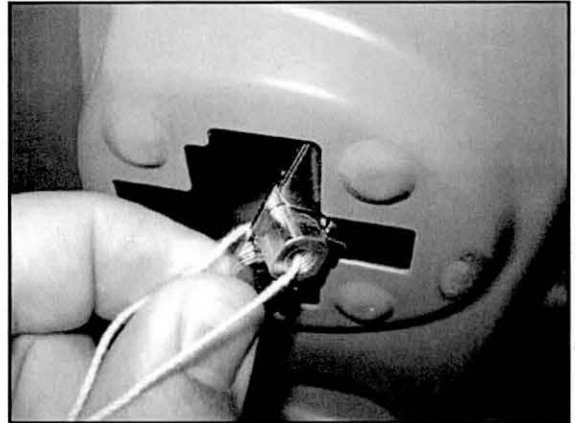

- C. Attach felt between the support and the roof panel to hold the support in place.

From the Noise Kit, cut 2 felt strips of the following dimensions:

Length: 25 mm (1 in.)

Width: 5 mm (3/16 in.)

Thickness: 0.5 mm (0.02 in.)

Figure 23.

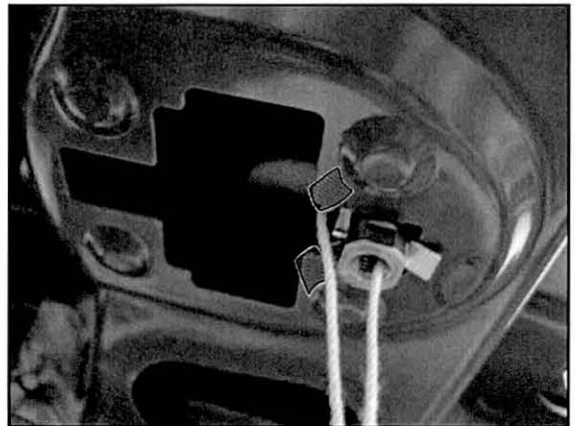

- D. Remove the string or wire from the support.

Sunvisor Mount Reinforcement Bracket Kit Installation

Repair Procedure

Without Sunvisor Vanity Light (Continued)

7. Install the rear visor support.
 - A. Thread string or thin wire through the opening of the support.

Figure 24.

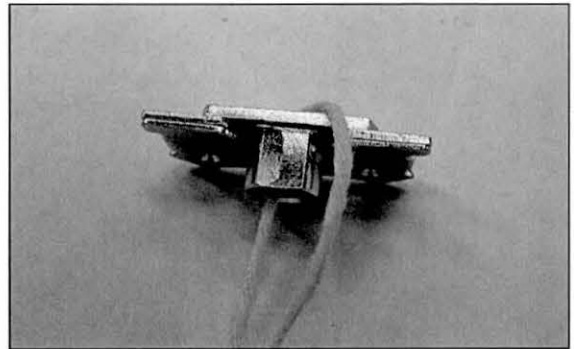

- B. Insert the support into the roof panel opening and attach the support hook to the rear edge of the roof panel opening.

Figure 25.

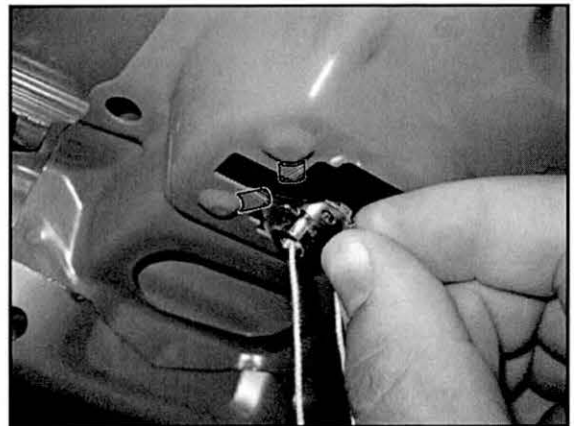

- C. Attach felt between the support and the roof panel to hold the support in place.

From the Noise Kit, cut 2 felt strips of the following dimensions:

Length: 25 mm (1 in.)

Width: 5 mm (3/16 in.)

Thickness: 0.5 mm (0.02 in.)

- D. Remove the string or wire from the support.

Sunvisor Mount Reinforcement Bracket Kit Installation

Repair Procedure

Without Sunvisor Vanity Light (Continued)

8. Install the brackets into the sunvisor base.
 - A. Remove the clips remaining in visor.
 - B. Insert 2 brackets into the visor base.

NOTE

- If the brackets are loose and fall out easily, install tape to temporarily hold the brackets in position.
- If the brackets are tight, use a clamp or other device to secure the brackets flush to the visor base.

Figure 26.

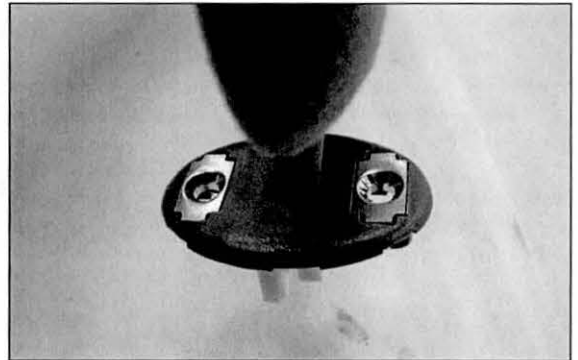

9. Install the visor assembly.
 - A. Insert the visor base partially into roof opening.
 - B. Install 2 screws into visor support.
Torque: 3.0 N*m (30 kgf*cm, 2.21 ft*lbf)

NOTE

- Do NOT push the screw into the support. This could cause the support to come loose.
- Remove the tape from the brackets if used in step 8B.

Figure 27.

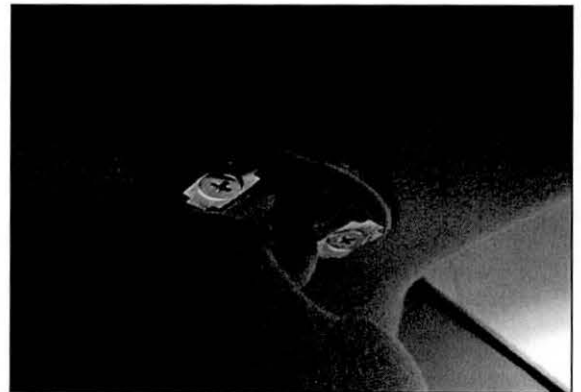

Sunvisor Mount Reinforcement Bracket Kit Installation

Repair Procedure

Without Sunvisor Vanity Light (Continued)

10. Install the cover from the Visor Repair Bracket Kit. Figure 28.

