

Blind Spot Monitor DTC C1AB4/C1AB5

Service Category Audio/Visual/Telematics

Section Park Assist/Monitoring

Market USA

Toyota Supports
 ASE Certification 

Applicability

YEAR(S)	MODEL(S)	ADDITIONAL INFORMATION
2013	Avalon HV	
2013	Avalon	

REVISION NOTICE

April 19, 2013 Rev1:

- The Production Change Information section has been updated.

Any previous printed versions of this bulletin should be discarded.

Introduction

Some 2013 model year Avalon and Avalon HV vehicles may display a "Check Blind Spot Monitor System" message on the multi-information display with Diagnostic Trouble Code (DTC) C1AB4 and/or C1AB5 stored. The procedure in this bulletin has been developed to address this condition.

Production Change Information

This bulletin applies to vehicles produced **BEFORE** the Production Change Effective VINs shown below.

MODEL	GRADE	PLANT	PRODUCTION CHANGE EFFECTIVE VIN
Avalon	Limited	TMMK	4T1BK1EB#DU007805
	Touring		4T1BK1EB#DU007797
Avalon HV			Limited

Blind Spot Monitor DTC C1AB4/C1AB5

Warranty Information

OP CODE	DESCRIPTION	TIME	OFF	T1	T2
EL1302	Repair Wire Harness (Both Sides)	1.0	87901-07020 87901-07030 87906-07060 87906-07050	72	71

APPLICABLE WARRANTY

- This repair is covered under the Toyota Basic Warranty. This warranty is in effect for 36 months or 36,000 miles, whichever occurs first, from the vehicle's in-service date.
- Warranty application is limited to occurrence of the specified condition described in this bulletin.

Parts Information

PREVIOUS PART NUMBER	CURRENT PART NUMBER	PART NAME	QTY
–	82999-52010	Sleeve	2
–	82999-30010	Thermo Contact Tube	3

Required Tools & Equipment

SPECIAL SERVICE TOOLS (SST)	PART NUMBER	QTY
Wire Crimper (Non Insulated)*	<u>09042-2C100</u>	1

NOTE

Additional SSTs may be ordered by calling 1-800-933-8335.

REQUIRED EQUIPMENT	SUPPLIER	PART NUMBER	QTY
Techstream 2.0*	ADE	TS2UNIT	1
TIS Techstream		TSPKG1	
Techstream Lite		TSLITEDLR01	

NOTE

- Only ONE of the Techstream units listed above is required.
- Software version 8.10.021 or later is required.
- Additional Techstream units may be ordered by calling Approved Dealer Equipment (ADE) at 1-800-368-6787.

* Essential SST.

Blind Spot Monitor DTC C1AB4/C1AB5

Inspection Procedure

Using Techstream, check for stored DTCs. Confirm one of the following DTCs is present:

- C1AB4 – Open in Outer Mirror Indicator (Master)
- C1AB5 – Open in Outer Mirror Indicator (Slave)

If DTC C1AB4 or C1AB5 is stored as a current or history DTC, complete the Repair Procedure to BOTH outer side rear view mirror assemblies.

If DTC C1AB4 or C1AB5 is NOT stored as current or history, STOP! This bulletin does NOT apply.

Refer to the Technical Information System (TIS), applicable model and model year Repair Manual:

- 2013 Avalon:
Audio/Visual/Telematics – Park Assist / Monitoring – “Park Assist / Monitoring: Blind Spot Monitor System: Problem Symptoms Table”
- 2013 Avalon HV:
Audio/Visual/Telematics – Park Assist / Monitoring – “Park Assist / Monitoring: Blind Spot Monitor System: Problem Symptoms Table”

Blind Spot Monitor DTC C1AB4/C1AB5

Repair Procedure

The following repair procedure will instruct how to remove the Blind Spot Monitor (BSM) indicator ground circuit from the harness and splice it into the Mirror Heater ground circuit.

NOTE

- Use the same procedure for both the RH and LH sides.
- The procedure described below is for the LH side.

1. Remove outer rear view mirror cover.

Refer to TIS, applicable model and model year Repair Manual:

- 2013 Avalon:
Vehicle Exterior – Mirror (Ext) – “Mirror (Ext): Outer Rear View Mirror Cover: Removal”
- 2013 Avalon HV:
Vehicle Exterior – Mirror (Ext) – “Mirror (Ext): Outer Rear View Mirror Cover: Removal”

2. Remove the tape from the two wire BSM indicator wire harness. Figure 1.

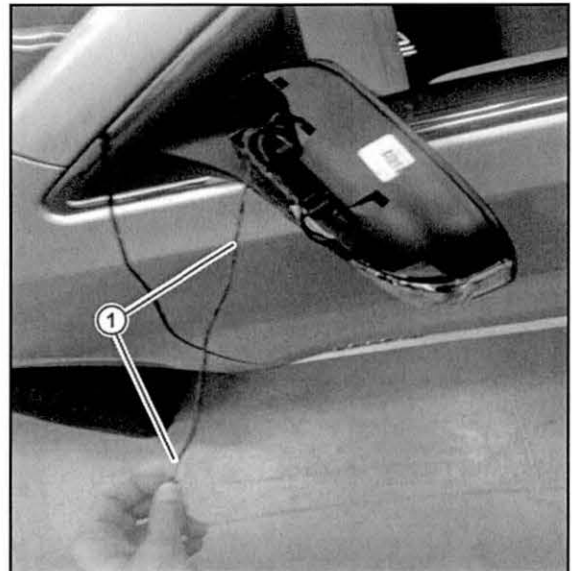

1	Tape Location
---	---------------

Blind Spot Monitor DTC C1AB4/C1AB5

Repair Procedure (Continued)

3. Measure 20 mm (0.79 in.) from the junction of the mirror harness and cut the YELLOW wire.

Figure 2.

NOTE

Mirror removed for illustration purposes only. Mirror does NOT need to be removed from vehicle.



1	Cut Location
---	--------------

4. Remove 8 mm (0.32 in.) of insulation from the end of the YELLOW BSM indicator ground wire leading to the connector.

Figure 3.

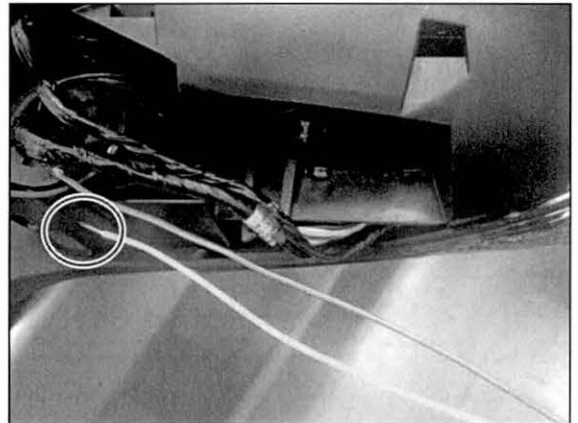

Blind Spot Monitor DTC C1AB4/C1AB5

Repair Procedure (Continued)

5. Install a barrel sleeve on to the end of the indicator ground wire.

NOTE
 Ensure wire is fully inserted into the sleeve.

Figure 4.

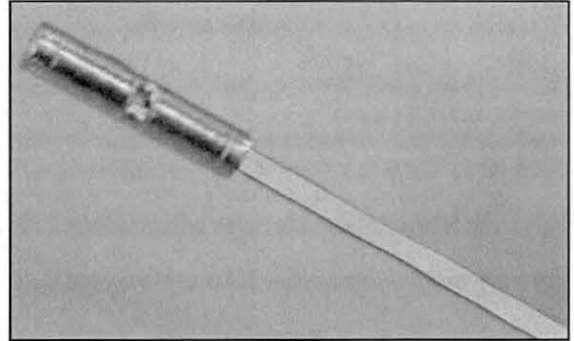
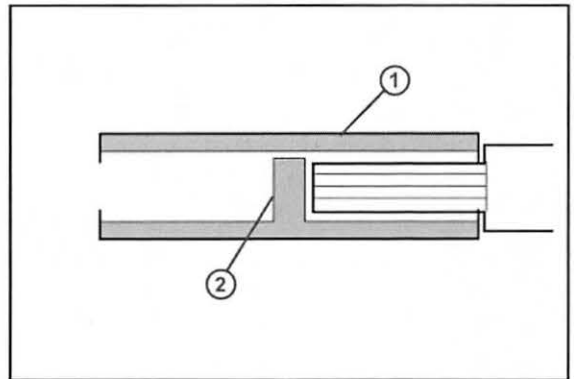

Figure 5.



1	Sleeve
2	Wire Stop

6. Place the sleeve into the 1.25 mm (0.05 in.) crimp die of the SST.

NOTE

- Place the sleeve into the SST so that the split in the sleeve is in the half circle of the SST.
- SST 09042-2C100 is the only tool approved to perform this repair. Do NOT use any other tool to crimp the sleeve.

Figure 6.

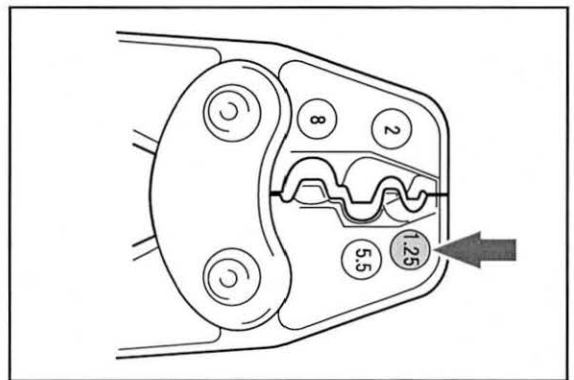

Blind Spot Monitor DTC C1AB4/C1AB5

Repair Procedure (Continued)

- With the sleeve correctly placed in the SST and wire fully inserted into the sleeve, crimp one side of the sleeve in the area shown by closing the handles fully until they release. Crimp the sleeve onto the BSM indicator ground wire.

NOTE

SST 09042-2C100 is the only tool approved to perform this repair. Do NOT use any other tool to crimp the sleeve.

- Install thermo tubing onto the BSM indicator ground wire.

- Locate the Mirror Heater ground wire (Brown w/Yellow). Measure 30 mm (1.18 in.) from the wire harness junction and cut the wire.

Figure 7.

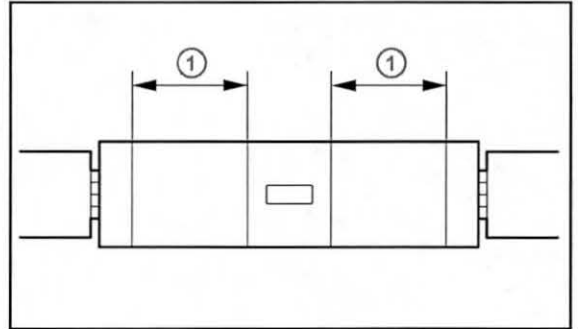

1	Crimp This Portion
---	--------------------

Figure 8.

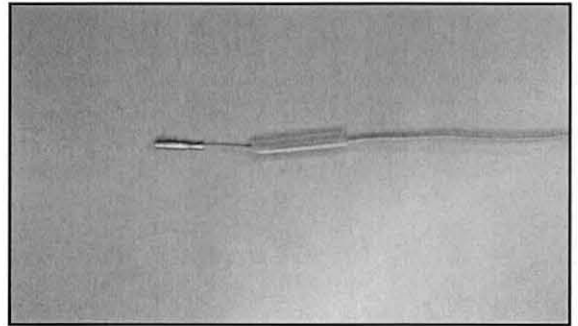
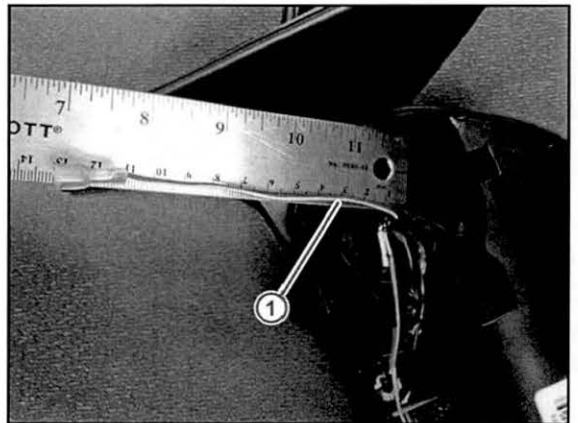

Figure 9.



1	Cut Location
---	--------------

Blind Spot Monitor DTC C1AB4/C1AB5

Repair Procedure (Continued)

- Remove 8 mm (0.32 in.) of insulation from both cut ends of the Mirror Heater ground wire.

Figure 10.

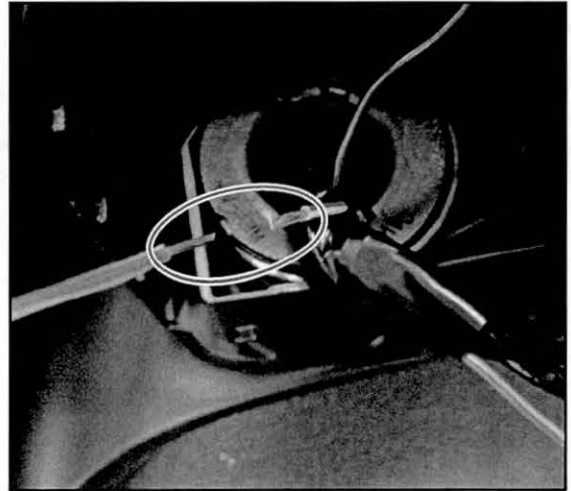

- Insert both ends of the Mirror Heater ground wire (Brown w/Yellow) into the remaining open end of the barrel sleeve and crimp using the SST.

NOTE

Do NOT twist ends of the wire together before inserting into the barrel sleeve.

Figure 11.

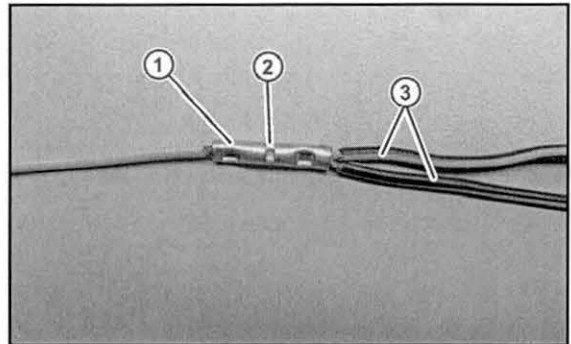

1	Sleeve
2	Wire Stop
3	Wires

- Lightly tug on each connection to ensure that the wire is securely crimped.

Figure 12.

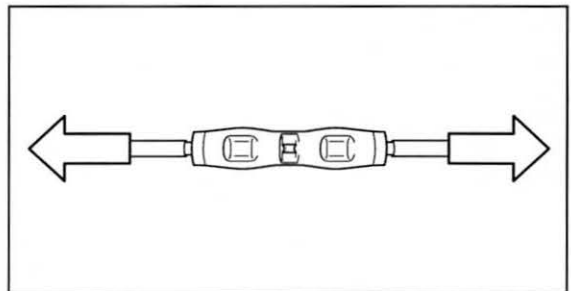

Blind Spot Monitor DTC C1AB4/C1AB5

Repair Procedure (Continued)

13. Position the thermo tube 8 mm (0.32 in.) past the end of the barrel sleeve. Figure 13.

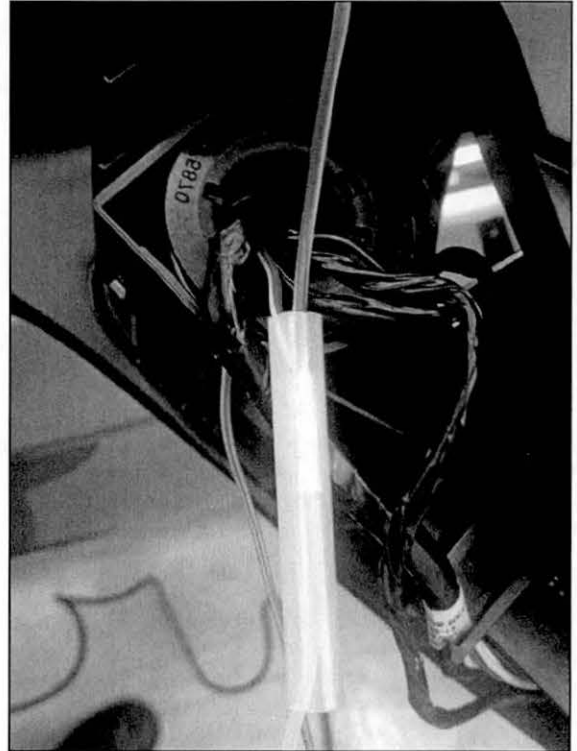

Blind Spot Monitor DTC C1AB4/C1AB5

Repair Procedure (Continued)

14. Using a heat gun, heat the thermo tubing until it shrinks and seals the repaired connection.

NOTICE

- When using the heat gun, keep the heat gun about 100 mm (0.39 in.) to 200 mm (7.8 in.) from the thermo tubing.
- Protect the surrounding areas (i.e., mirror assembly, interior panels, and door) from heat damage.

NOTE

During the sealing process, adhesive may seep from the thermo tubing. This is a normal condition and part of the sealing properties of the thermo tube.

Figure 14.

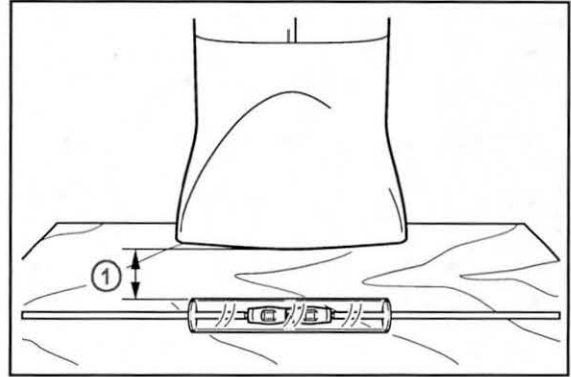

1	100 mm (3.9 in.) to 200 mm (7.8 in.)
---	--------------------------------------

Figure 15.

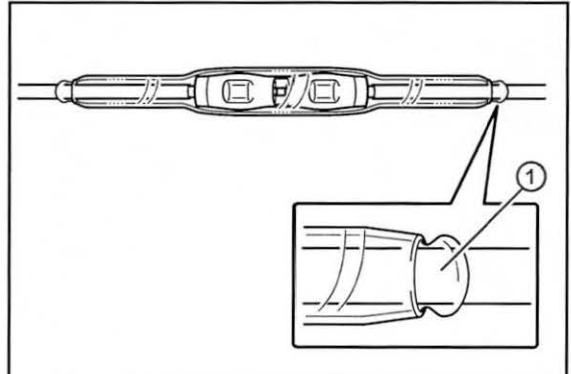

1	Adhesive
---	----------

Blind Spot Monitor DTC C1AB4/C1AB5

Repair Procedure (Continued)

15. Use the thermo tube to seal the cut end of the BSM ground wire at the wire harness junction.

A. Cut a thermo tube in the center to make two 30 mm (1.18 in.) pieces. (Use one piece for each side.)

B. Place thermo tube on cut wire end, leaving the tube extending 8 mm (0.32 in.) past the end of the wire.

Figure 16.

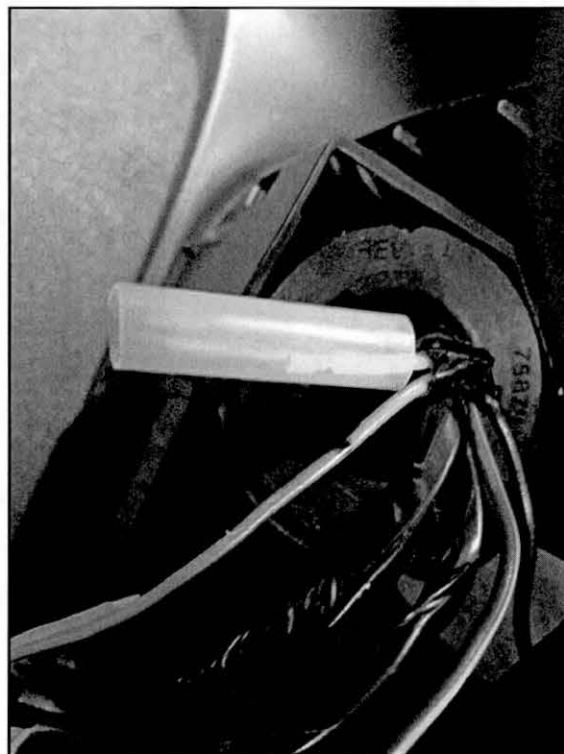

C. Using a heat gun, heat the thermo tubing until it shrinks and seals the wire end.

NOTICE

- When using the heat gun, keep the heat gun about 100 mm (0.39 in.) to 200 mm (7.8 in.) from the thermo tubing.
- Protect the surrounding areas (i.e., mirror assembly, interior panels, and door) from heat damage.

NOTE

During the sealing process, adhesive may seep from the thermo tubing. This is a normal condition and part of the sealing properties of the thermo tube.

Blind Spot Monitor DTC C1AB4/C1AB5

Repair Procedure (Continued)

16. Insulate the BSM indicator wire harness by wrapping with electrical tape.

Figure 17.

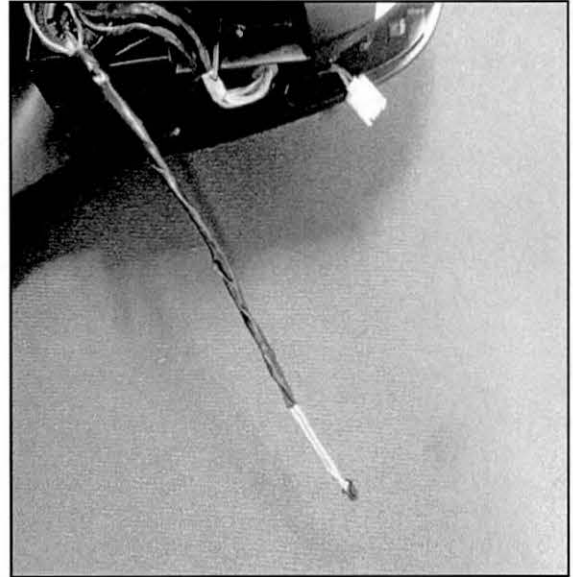

17. Install outer rear view mirror cover.

Refer to TIS, applicable model and model year Repair Manual:

- 2013 Avalon: *Vehicle Exterior – Mirror (Ext) – “Mirror (Ext): Outer Rear View Mirror Cover: Installation”*
- 2013 Avalon HV: *Vehicle Exterior – Mirror (Ext) – “Mirror (Ext): Outer Rear View Mirror Cover: Installation”*

18. Verify Blind Spot Monitor Mirror indicators operate normally.
19. Clear Blind Spot Monitor System DTCs with Techstream.