

Service Bulletin

Mazda North American Operations
Irvine, CA 92618-2922



MAZDA

© 2013 Mazda Motor of America, Inc.

Subject: WHITE STAINS FROM OUTER DOOR MIRROR RUNNING DOWN DOOR PANEL	Bulletin No: 09-028/13
	Last Issued: 10/31/2013

APPLICABLE MODEL(S)/VINS

2013-2014 CX-5 vehicles with VINs **between JM3KE*****138997 ~ 398338** and produced from July 24, 2012, to October 1, 2013

DESCRIPTION

Some vehicles may exhibit a white stain running down the front door(s), which originates from under the outer door mirror. This is caused when water (containing white corrosion) is generated inside the door mirror base, then drains down the door panel causing a poor appearance concern.

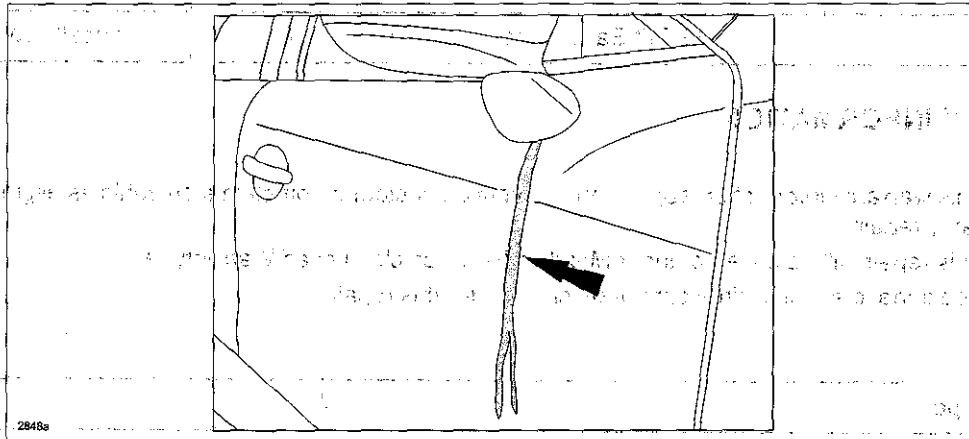

The door mirror base was originally designed to drain water to the outside of the door. The shape of the door mirror base gasket has been modified to now drain water to the inside of the door. Replacing the gasket should eliminate this concern.

Customers with this concern should have their vehicle repaired according to the following repair information.

CONSUMER NOTICE: The information and instructions in this bulletin are intended for use by skilled technicians. Mazda technicians utilize the proper tools/equipment and take training to correctly and safely maintain Mazda vehicles. These instructions should not be performed by "do-it-yourselfers." Customers should not assume this bulletin applies to their vehicle or that their vehicle will develop the described concern. To determine if the information applies, customers should contact their nearest authorized Mazda dealership. Mazda North American Operations reserves the right to alter the specifications and contents of this bulletin without obligation or advance notice. All rights reserved. No part of this bulletin may be reproduced in any form or by any means, electronic or mechanical—including photocopying and recording and the use of any kind of information storage and retrieval system—without permission in writing.

REPAIR PROCEDURE

1. Verify the customer concern.
2. Remove the power door mirrors on both sides according to the instructions in Workshop Manual "POWER OUTER MIRROR REMOVAL/INSTALLATION".
3. Remove the gasket (A) from the mirror base.

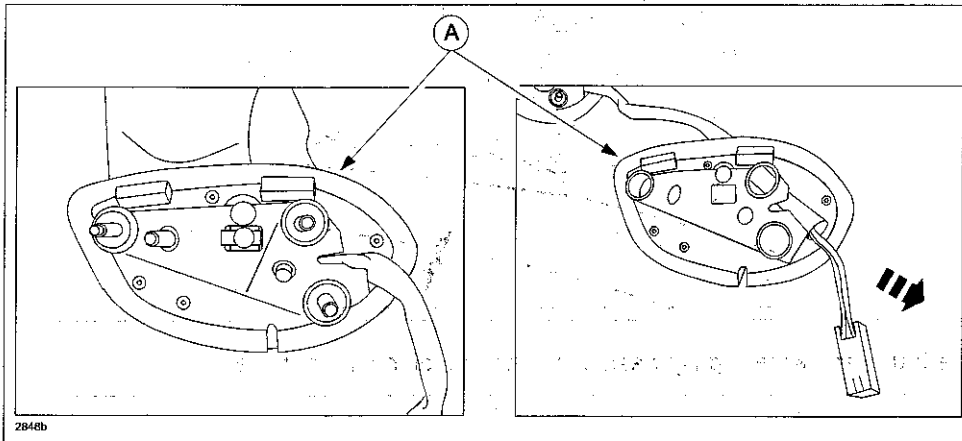

4. To prevent scratching, apply masking tape to the mirror base cover as shown below.

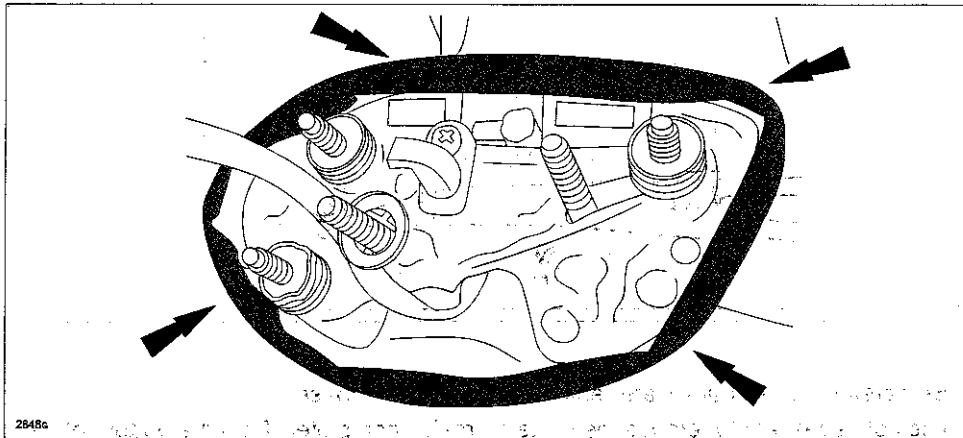

5. Using a soft brush and water, wash away white corrosion found at the bottom of the mirror base.

NOTE: Be careful not to let any water enter inside the mirror base.

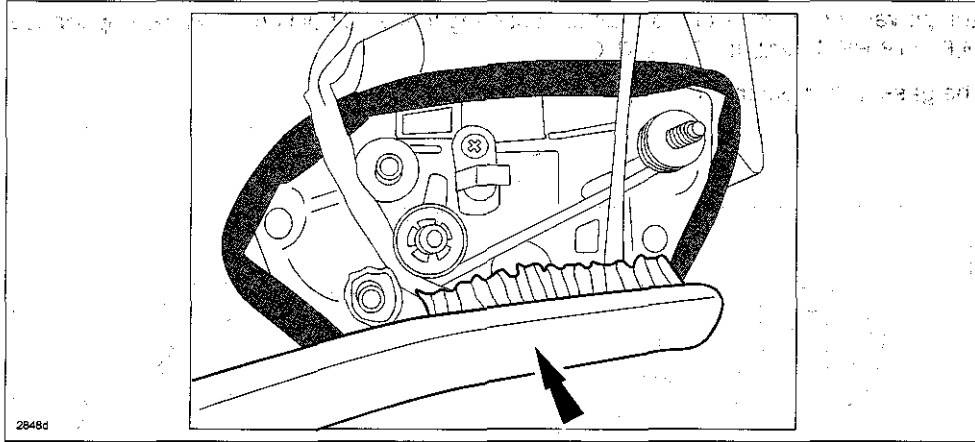

6. Using a wire brush and water, lightly wash off the bottom of the mirror base.

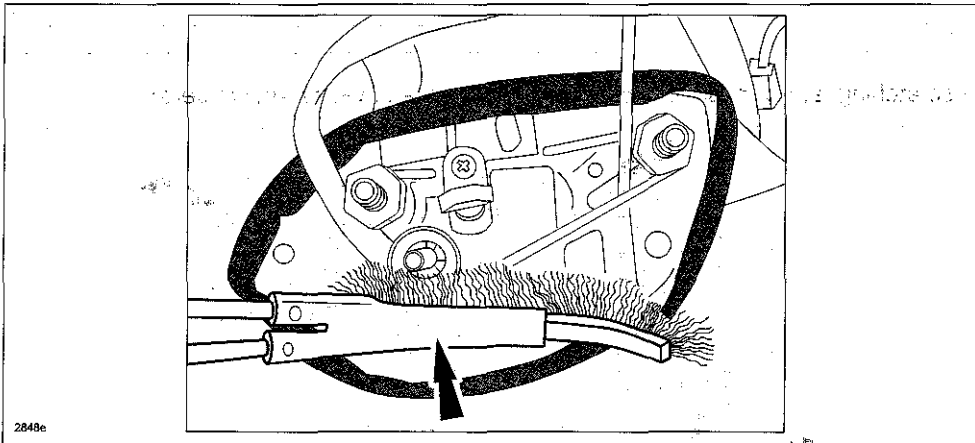

NOTE:

- Be careful not to let any water enter inside the mirror base.
- It is not necessary to remove the white corrosion completely from the bottom of the mirror base. It will not affect the functionality and durability of the door mirror.
- It is sufficient to remove white corrosion to the extent that it can be removed by lightly scrubbing it with a wire brush.

7. Remove the masking tape, then wipe any remaining water off the mirror base and let it air dry.

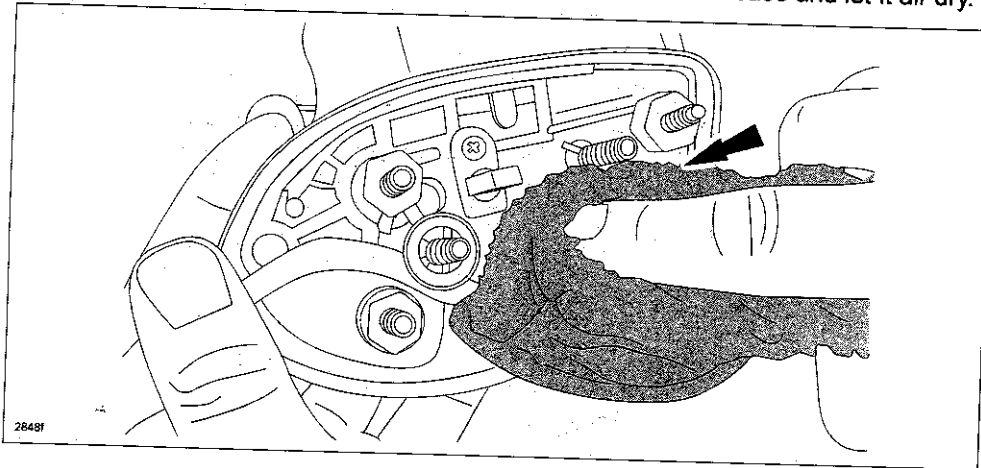

8. To prevent applying ValuGard Rust Preventative to the base cover (A); stud bolts (B) and harness (C), first apply masking tape to the mirror base as shown below.

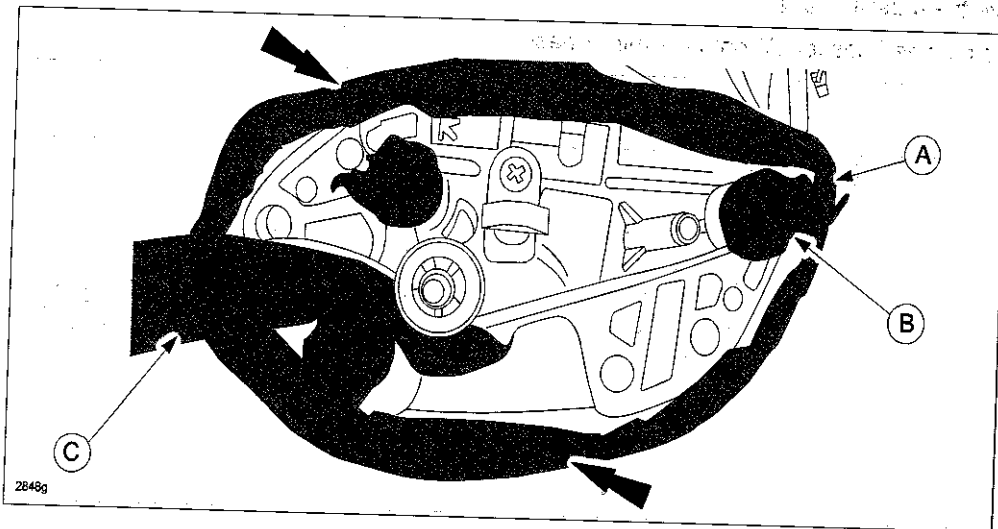

9. To prevent future corrosion to the mirror base, apply **ValuGard Rust Preventative** to the base.

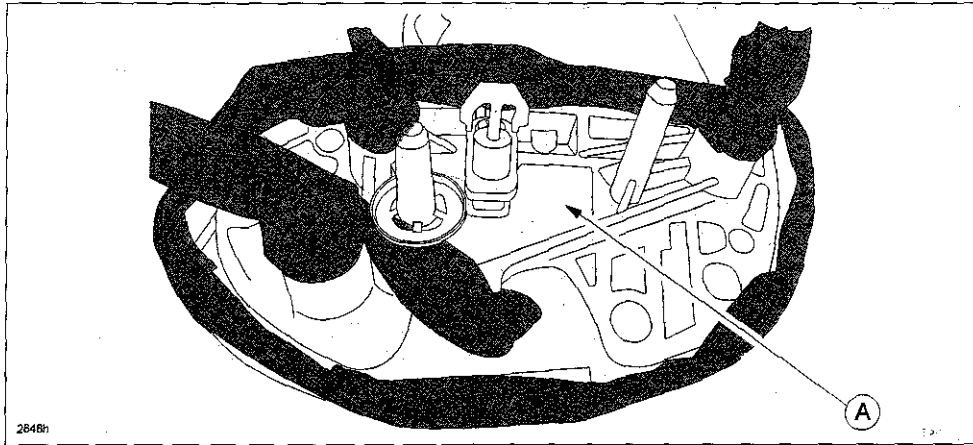

10. Let the **ValuGard Rust Preventative** product air dry.
11. Remove the masking tape.
12. Install a modified gasket (A) onto the mirror base.

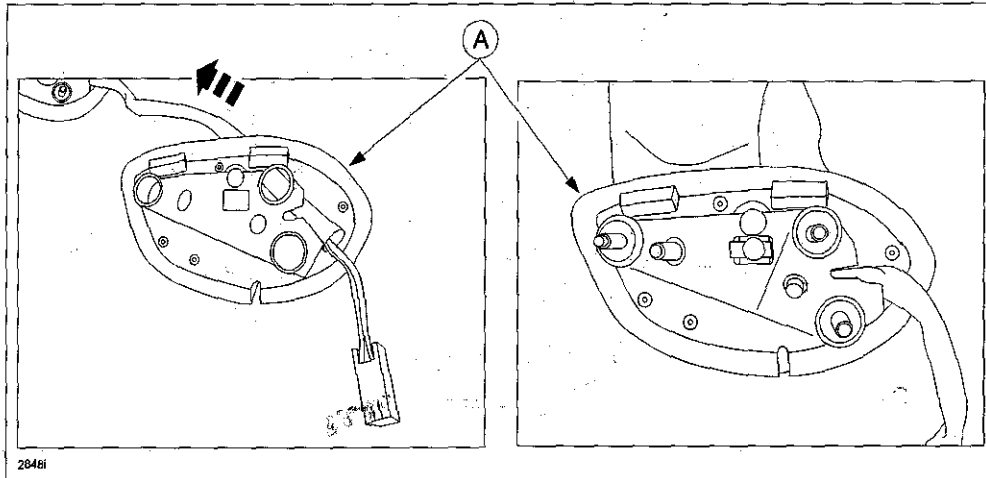

13. Reinstall both power door mirrors according to the instructions in Workshop Manual "POWER OUTER MIRROR REMOVAL/INSTALLATION".
14. Verify repair.



Bulletin No: 09-028/13 © 2013 Mazda Motor of America, Inc.	Last Issued: 10/31/2013
--	--------------------------------

PART(S) INFORMATION

Part Number	Description	Qty.	Notes
KR82-69-18Y	Gasket (L)	1	---
KR82-69-12Y	Gasket (R)	1	---

- NOTE:**
- Order **ValuGard Rust Preventative** directly from Automotive International, Inc. (800) 543-7156 (Mon. - Fri., 8:00 am to 5:00 pm EST) or go to www.valugard.net.
 - Invoice to dealer directly. All shipments FOB from Cincinnati, OH.
 - Shelf life: Approx. two (2) years.

WARRANTY INFORMATION

- NOTE:**
- This warranty information applies only to verified customer complaints on vehicles eligible for warranty repair.
 - This repair will be covered under Mazda's New Vehicle Limited Warranty term.
 - Additional diagnostic time cannot be claimed for this repair.

Warranty Type	A
Symptom Code	98
Damage Code	9Y
Part Number Main Cause	KR82-69-18Y
Quantity	1
Operation Number / Labor Hours:	XXJD6XRX / 0.7 Hrs. (Both sides)

- NOTE:**
- The cost of the **ValuGard Rust Preventative** is included in the labor time.
 - Enter KR82-69-12Y (Gasket (R)) as a related part number.