

© 2013 Mazda Motor of America, Inc.

Subject: NOISE COMING FROM UNDER THE DRIVER SEAT	Bulletin No: 09-026/13
	Last Issued: 10/09/2013

APPLICABLE MODEL(S)/VINS

2013 CX-5 vehicles without power seats with VINs lower than JM3KE*****144861 (produced Aug. 24, 2012)

DESCRIPTION

Some vehicles may exhibit a noise from under the driver seat while driving the vehicle. The noise may be caused by vibration when the bent-up end of the balance spring (A) interferes with the slider bushing (B).

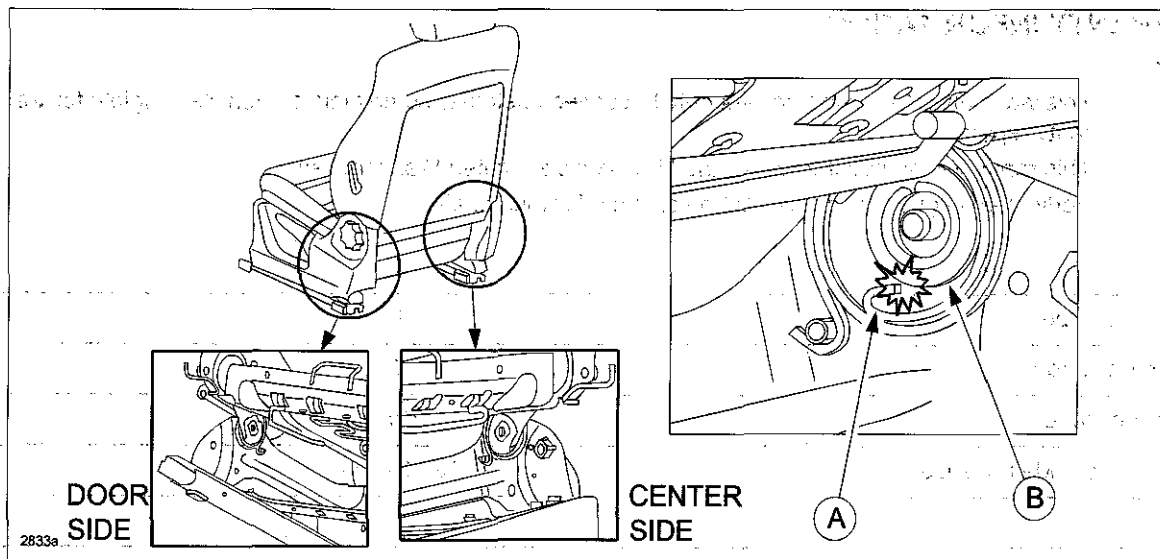

To eliminate the noise, the clearance between the balance spring and the slider bushing has been increased. Customers having this concern should have their vehicle repaired using the following repair procedure.

REPAIR PROCEDURE

1. Verify that the noise is coming from the seat lifter area of the driver seat.
2. Set the driver seat lifter to the highest position.
3. Remove the driver seat according to the on-line instructions on MS3 or the Workshop Manual (section 09-13 FRONT SEAT REMOVAL/INSTALLATION).
4. Turn the seat upside down on a clean surface, then locate the grease points (A).

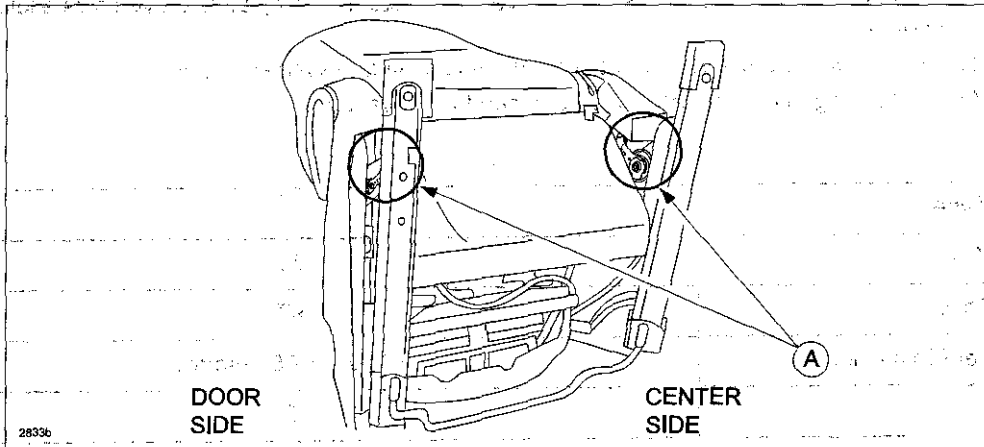

5. Locate the bracket holes (A). Insert the grease spray nozzle (B) into each bracket hole all the way inside until the nozzle touches the interference point (C).

NOTE: Recommended grease: Molybdenum disulphide grease

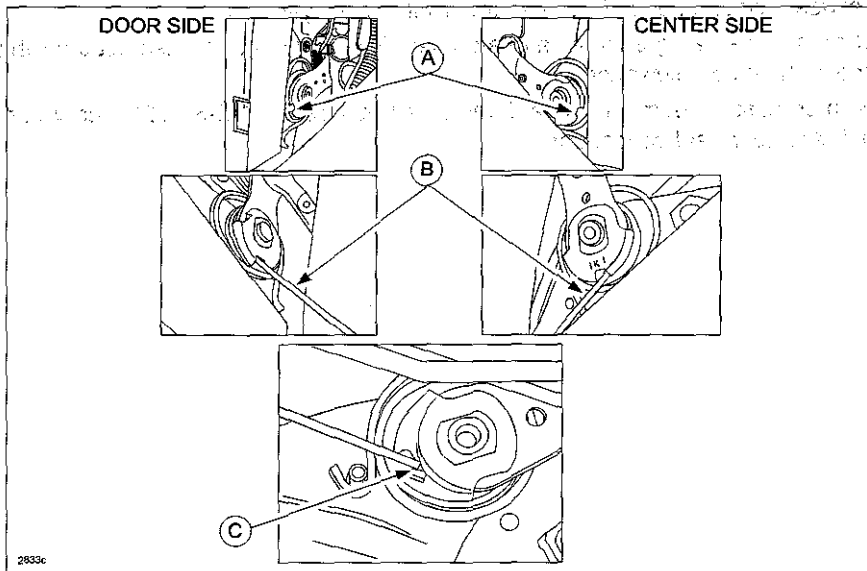

6. Spray the grease for only (1) one second.

NOTE: If too much grease is sprayed, the excess will adhere between the balance spring plates and cause a new noise.

Bulletin No: 09-026/13 © 2013 Mazda Motor of America, Inc.	Last Issued: 10/09/2013
--	--------------------------------

7. Re-install the driver seat according to the on-line instructions on MS3 or the Workshop Manual (section 09-13 FRONT SEAT REMOVAL/INSTALLATION).
8. Verify the repair.

WARRANTY INFORMATION

NOTE:

- This warranty information applies only to verified customer complaints on vehicles eligible for warranty repair.
- This repair will be covered under the New Vehicle Limited Warranty term.
- Additional diagnostic time cannot be claimed for this repair.

Warranty Type	A
Symptom Code	82
Damage Code	97
Part Number Main Cause	GS1M-88-651 (screw)
Quantity	0
Operation Number / Labor Hours	XXJBXXRX / 0.3 Hrs. (Driver seat only)

NOTE:

- This service bulletin does not apply to vehicles equipped with power seats.
- This service bulletin does not apply to the front passenger seat.
- Do not claim the spray grease as a related part. The amount of grease used for this repair is included in the labor allowance.
- For claim processing purposes, use dummy part number GS1M-88-651 (screw) as the PNMC, although it is not a real causal part.