

# Service Bulletin

Mazda North American Operations  
Irvine, CA 92618-2922



© 2013 Mazda Motor of America, Inc.

<b>Subject:</b>  DOOR TRIM ARM REST SURFACE PEELING	<b>Bulletin No:</b> 09-024/13
	<b>Last Issued:</b> 09/17/2013

## BULLETIN NOTE

- This bulletin supersedes the previous bulletin 09-003/12, issued on 01/31/12. The APPLICABLE MODEL(S)/VINS information has been revised.
- Changes are noted below in Red beside the change bar.

## APPLICABLE MODEL(S)/VINS

2010-2012 CX-7

## DESCRIPTION

On some vehicles, the surface of the door trim arm rest may peel off, resulting in poor appearance. This may be caused by poor adhesion. The surface may peel when the arm rest is grabbed by hand.

As a mass-production improvement, additional adhesion has been applied to the arm rest surface.

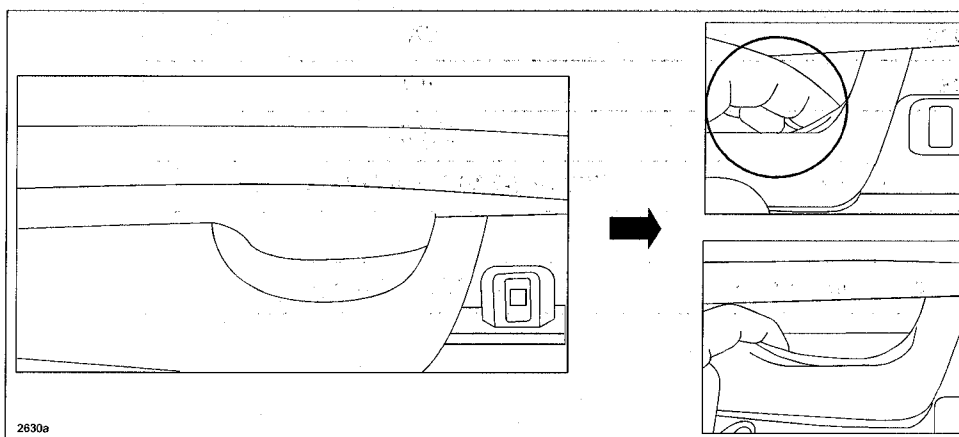

Customers having this concern should have their vehicle repaired using the following repair procedure.

Page 1 of 7

**CONSUMER NOTICE:** The information and instructions in this bulletin are intended for use by skilled technicians. Mazda technicians utilize the proper tools/equipment and take training to correctly and safely maintain Mazda vehicles. These instructions should not be performed by "do-it-yourselfers." Customers should not assume this bulletin applies to their vehicle or that their vehicle will develop the described concern. To determine if the information applies, customers should contact their nearest authorized Mazda dealership. Mazda North American Operations reserves the right to alter the specifications and contents of this bulletin without obligation or advance notice. All rights reserved. No part of this bulletin may be reproduced in any form or by any means, electronic or mechanical---including photocopying and recording and the use of any kind of information storage and retrieval system ---without permission in writing.

## REPAIR PROCEDURE

### NOTE:

- Ensure the door trim is kept clean during the repair.
- All illustrations shown below are of the front door trim, but the procedure is same for the rear door trim.

1. Verify customer concern.
2. Remove the applicable door trim according to the MS3 online instructions or the Workshop Manual (section 09-17 FRONT DOOR TRIM REMOVAL/INSTALLATION or REAR DOOR TRIM REMOVAL/INSTALLATION).
3. Remove the center decorative panel screws.
  - Door trim without a grip: 13 screws

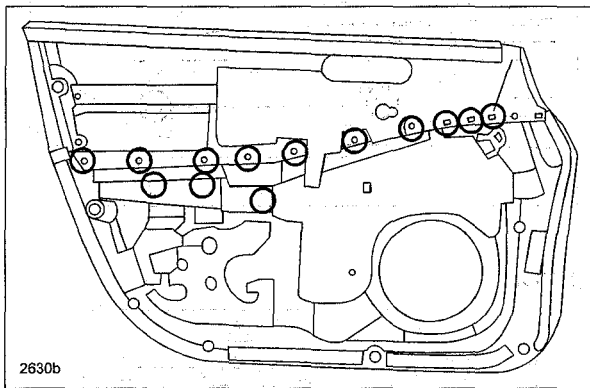

- Door trim with a grip: 14 screws

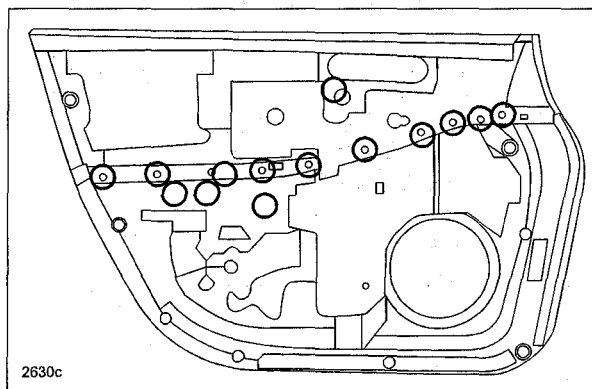

4. Remove the screws and the switch unit.

- Driver side: 3 screws

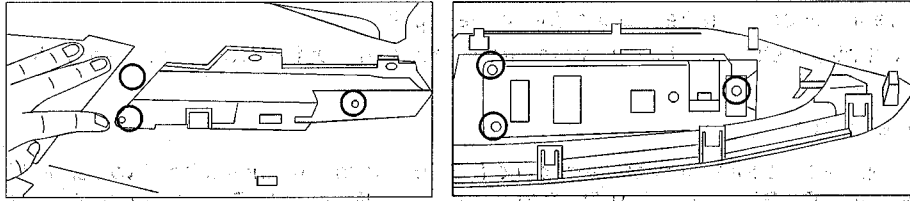

- Passenger side: 2 screws

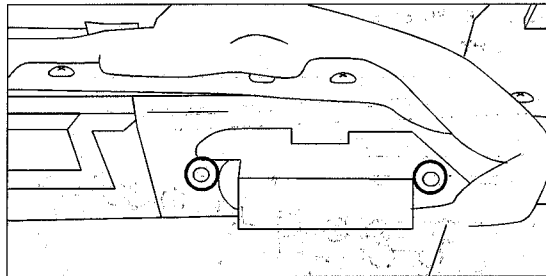

5. Detach the door trim tabs.

- Door trim without a grip: 5 tabs

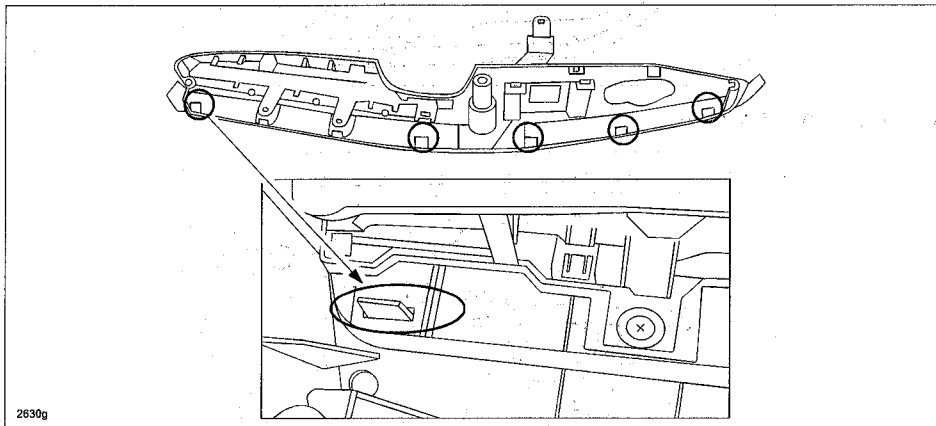

2630g

- Door trim with a grip: 5 tabs (A) and 1 tab (B) for grip.

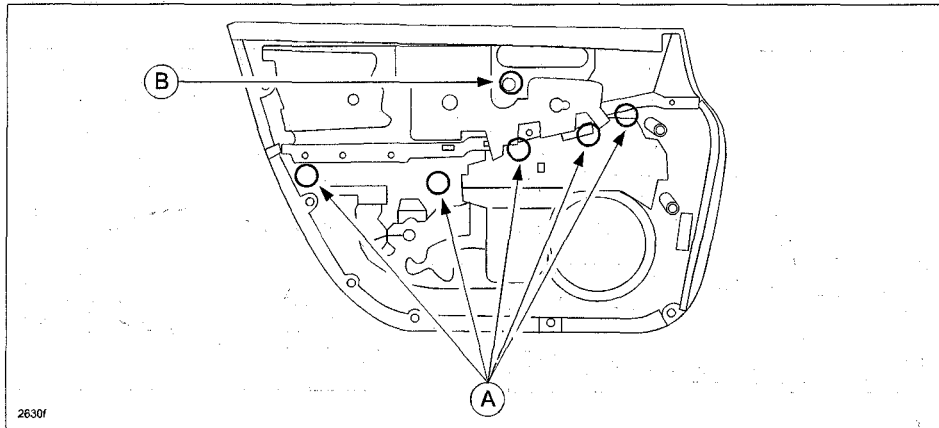

6. Detach tab (1) and push tab (2). Pull the frame to remove it from the door trim.

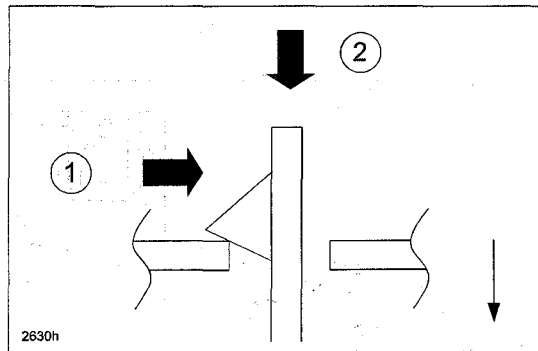

- Start removing the frame from the rear side of the vehicle, then move to the front side.
- Remove the decorative frame (A), switch panel (B), arm rest (D) and grip (C) all together.

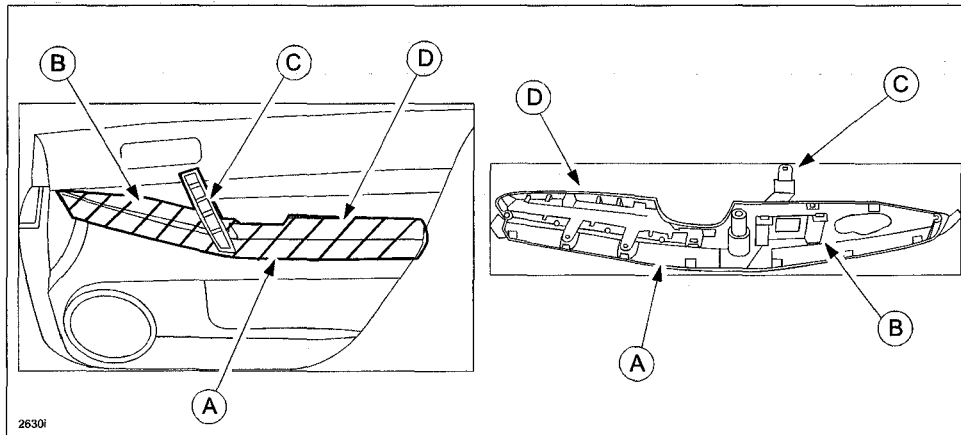

7. For door trim with a grip only: Remove the grip from the decorative frame by detaching 2 tabs (A).

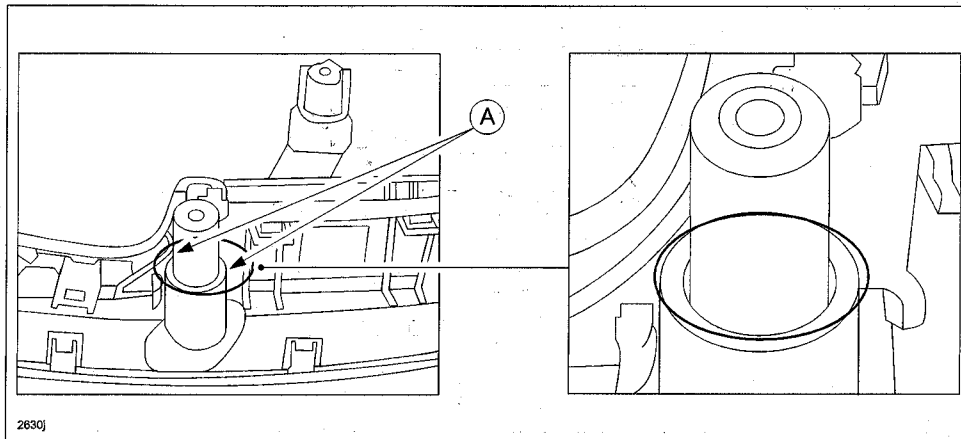

8. Remove the switch panel from the decorative frame by detaching the tabs (A).

- Drive side: 8 tabs
- Passenger side: 7 tabs

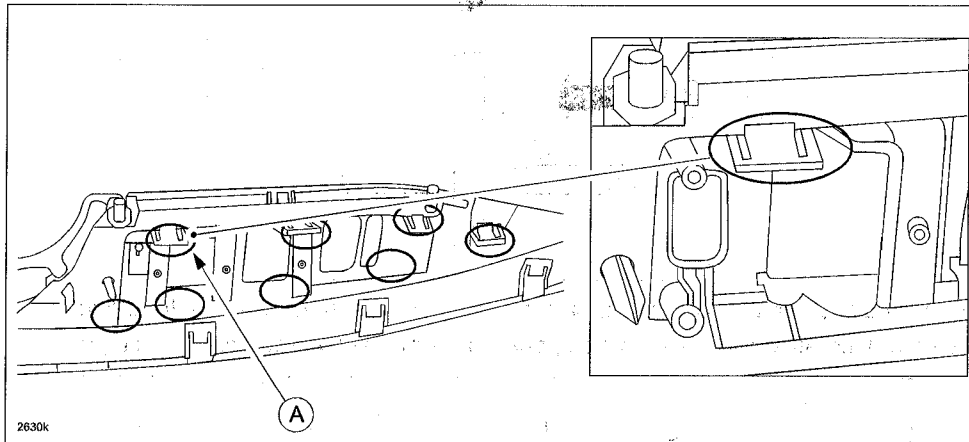

9. Remove the arm rest from the decorative panel.
  - Detach 5 tabs (A).
  - Remove a pin (B).

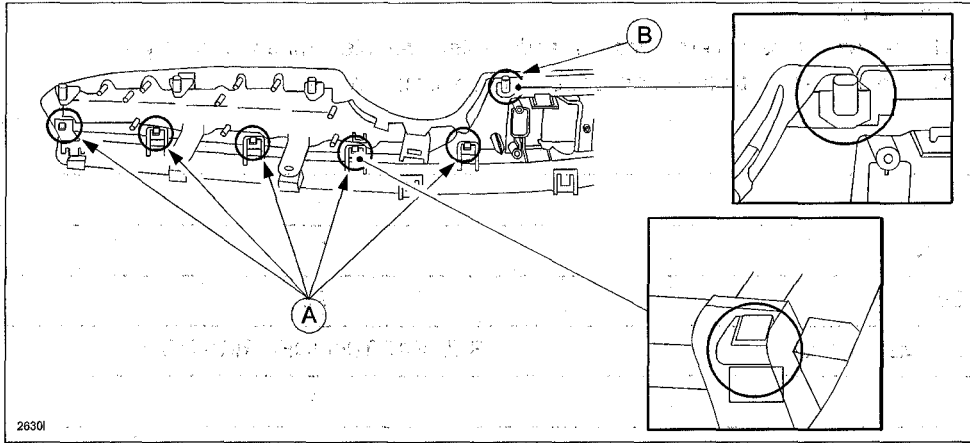

10. Replace the arm rest with a modified part.
11. Install in the reverse order of removal.
12. Verify repair.

### PART(S) INFORMATION

Part Number	Description	Qty.	Color
EH44-69-371 -02	Arm Rest (Front, Right)	1	Black
EH44-69-371 -34	Arm Rest (Front, Right)	1	Tan
EH44-69-391 -02	Arm Rest (Front, Left)	1	Black
EH44-69-391 -34	Arm Rest (Front, Left)	1	Tan
EH44-69-376A-02	Arm Rest (Rear, Right)	1	Black
EH44-69-376A-34	Arm Rest (Rear, Right)	1	Tan
EH44-69-396A-02	Arm Rest (Rear, Left)	1	Black
EH44-69-396A-34	Arm Rest (Rear, Left)	1	Tan

### WARRANTY INFORMATION

**NOTE:**

- This warranty information applies only to verified customer complaints on vehicles eligible for warranty repair.
- This repair will be covered under Mazda's New Vehicle Limited Warranty term.
- Additional diagnostic time cannot be claimed for this repair.

Warranty Type	A
Symptom Code	92
Damage Code	9L
Part Number Main Cause	SEE PART(S) INFORMATION
Quantity	1
Operation Number / Labor Hours:	XXG7FXRX / 0.5 Hrs. (1 arm rest replaced) XXG7GXRX / 0.8 Hrs. (2 arm rests replaced) XXG7HXRX / 1.1 Hrs. (3 arm rests replaced) XXG7JXRX / 1.4 Hrs. (4 arm rests replaced)