

© 2013 Mazda Motor of America, Inc.

Subject: SUNROOF WATER LEAK AFTER HIGH PRESSURE CAR WASH	Bulletin No: 09-014/13
	Last Issued: 05/03/2013

APPLICABLE MODEL(S)/VINS

2014 Mazda6 vehicles with VINs lower than JM1 GJ ***** 104218 (produced before December 15, 2012)

2013 CX-5 vehicles with VINs lower than JM3 KE ***** 153208 (produced before October 02, 2012)

2007-2013 CX-9 vehicles with VINs lower than JM3 TB ***** 400375 (produced before October 10, 2012)

DESCRIPTION

Some customers may experience a water leak from the sunroof after washing the vehicle with a high-pressure car wash system. High pressure water from the car wash may drip from the drip rail and leak into the cabin.

Customers having this concern should have their vehicle repaired using the following repair procedure.

REPAIR PROCEDURE

Replace the sunroof drip rail.

NOTE: This repair will reduce the water leak concern. Depending on the water pressure being used by the car wash facility, some water leaks after this repair may be normal.

1. Verify customer concern.
2. Remove the sunroof glass panel (A). Refer to MS3 online or Workshop Manual:
 - Mazda6 - (section 09-15 GLASS PANEL REMOVAL/INSTALLATION).
 - CX-5 - (section 09-15 GLASS PANEL REMOVAL/INSTALLATION).
 - CX-9 - (section 09-15 GLASS PANEL REMOVAL/INSTALLATION).

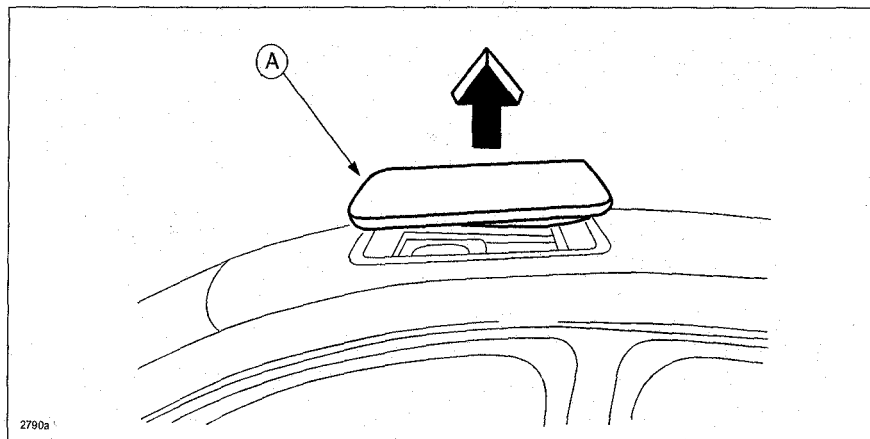

3. Replace the drip rail (B). Refer to MS3 online or Workshop Manual:
 - Mazda6 - (section 09-15 SUNROOF UNIT DISASSEMBLY/ASSEMBLY).
 - CX-5 - (section 09-15 SUNROOF UNIT DISASSEMBLY/ASSEMBLY).
 - CX-9 - (section 09-15 SUNROOF UNIT DISASSEMBLY/ASSEMBLY).

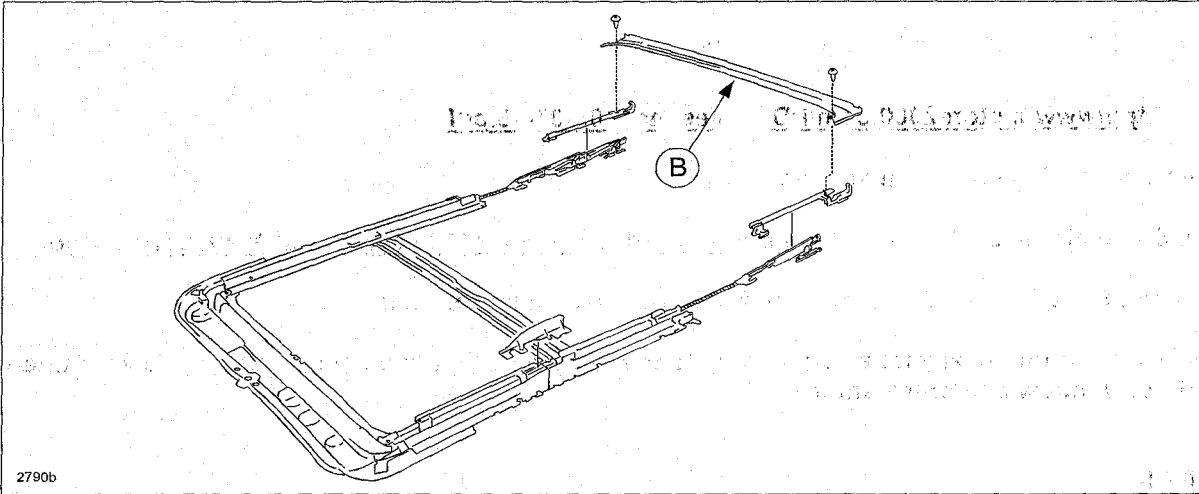

4. Install in the reverse order of removal.
5. Verify repair.

PART(S) INFORMATION

Part Number	Description	Qty.
KD47-69-867	Drip Rail	1

WARRANTY INFORMATION

NOTE:

- This warranty information applies only to verified customer complaints on vehicles eligible for warranty repair.
- This repair will be covered under Mazda's New Vehicle Limited Warranty term.
- Additional diagnostic time cannot be claimed for this repair.

Warranty Type	A
Symptom Code	77
Damage Code	97
Part Number Main Cause	KD47-69-867
Quantity	1
Operation Number / Labor Hours:	XXJ5BXRX / 0.4 Hrs.