

© 2013 Mazda Motor of America, Inc.

<b>Subject:</b>  RATTLE NOISE FROM PASSENGER SIDE DASHBOARD	<b>Bulletin No:</b> 09-008/13
	<b>Last Issued:</b> 03/21/2013

## APPLICABLE MODEL(S)/VINS

2014 Mazda6 vehicles with VINs lower than JM1 GJ \*\*\*\*\* 109218 (produced before February 4, 2013)

## DESCRIPTION

Some vehicles may exhibit a rattle type noise from the passenger side dashboard when driving on a rough road.

This noise may be caused by the passenger-side air bag module bracket (C) contacting the bracket holder (B) when driving on a rough road.

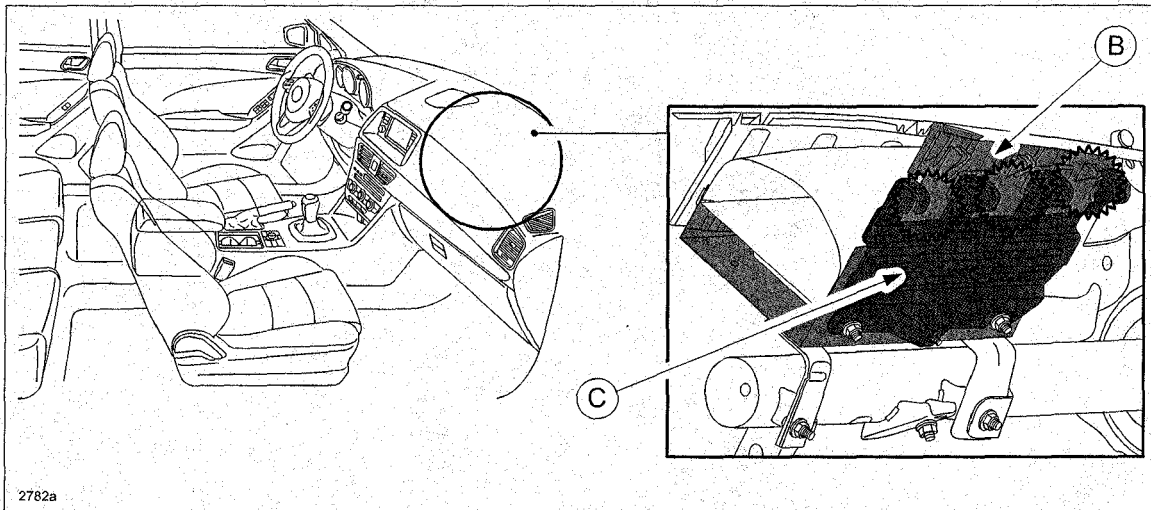

Customers having this concern should have their vehicle repaired using the following repair procedure.

## REPAIR PROCEDURE

Add non-woven fabric between the passenger-side air bag module bracket and the bracket holder.

1. Verify customer concern by lightly tapping on the passenger side of the dashboard. If the noise occurs, proceed to step 2.

2. Remove the glove compartment (A).
  - a. Push the glove compartment end (B) in the direction of the arrow (1) and remove hooks (C).

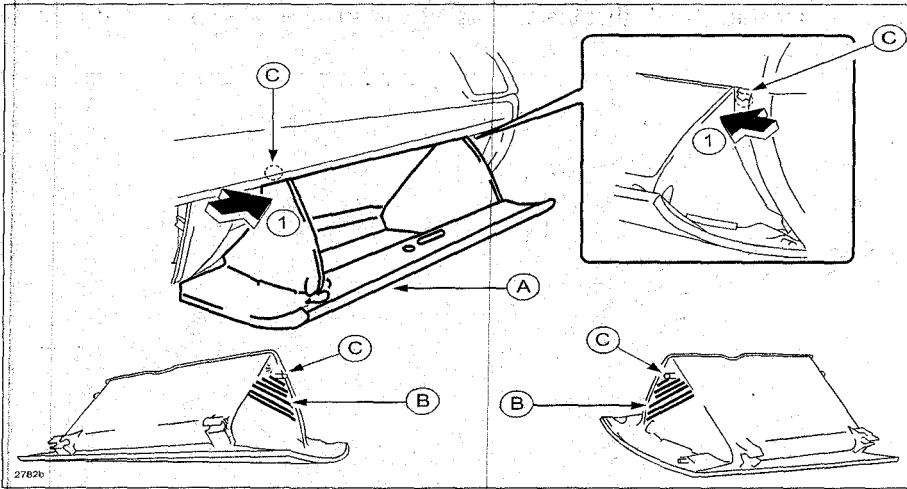

**CAUTION:** When disengaging hooks (C), the hooks could interfere with the lower panel (E) and cause scratches or damage at location (D). When removing hooks (C), press in the ends of the glove compartment (B) to a location which does not interfere with the lower panel (E).

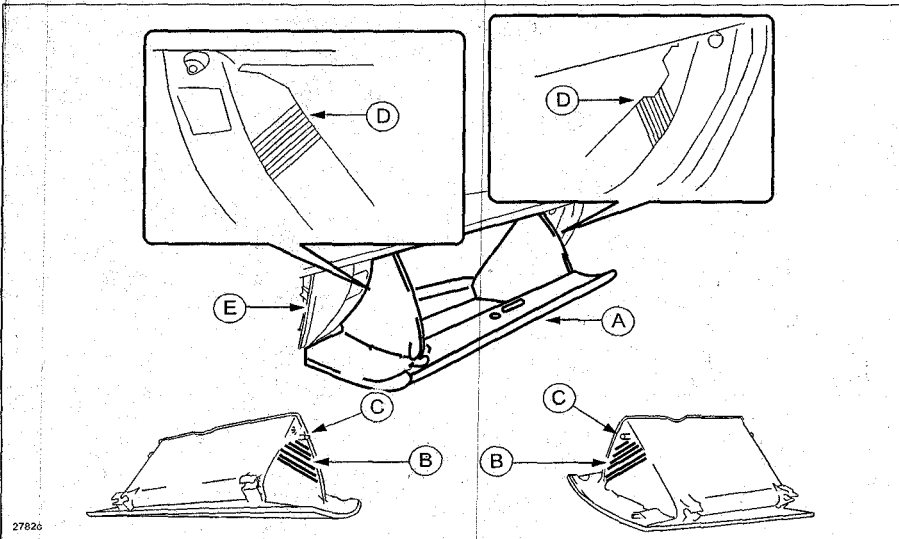

- b. Detach the stay damper (C) from hook (B) in the direction of the arrow (2) shown below.

**CAUTION:** If the glove compartment (A) is closed without attaching the stay damper (C), the stay damper may be damaged. Verify that the stay damper is attached to hook (B) before closing the glove compartment.

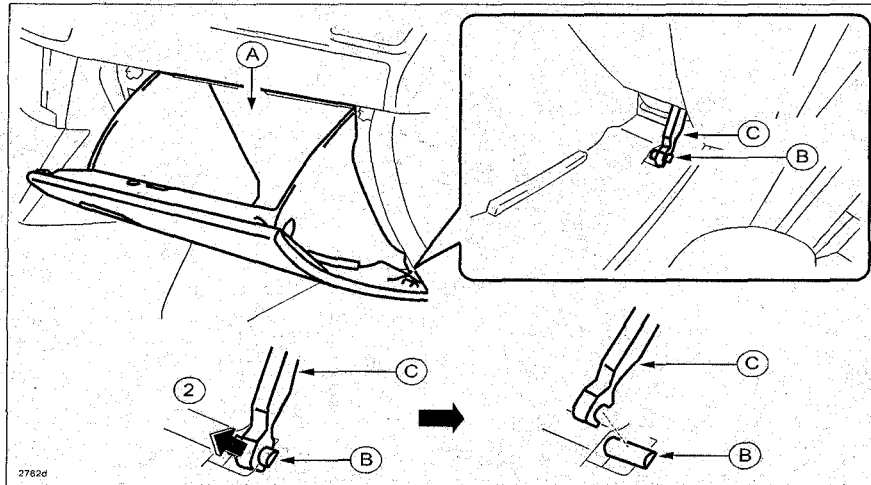

- c. Pull down the glove compartment (A) in the direction of the arrow (3).

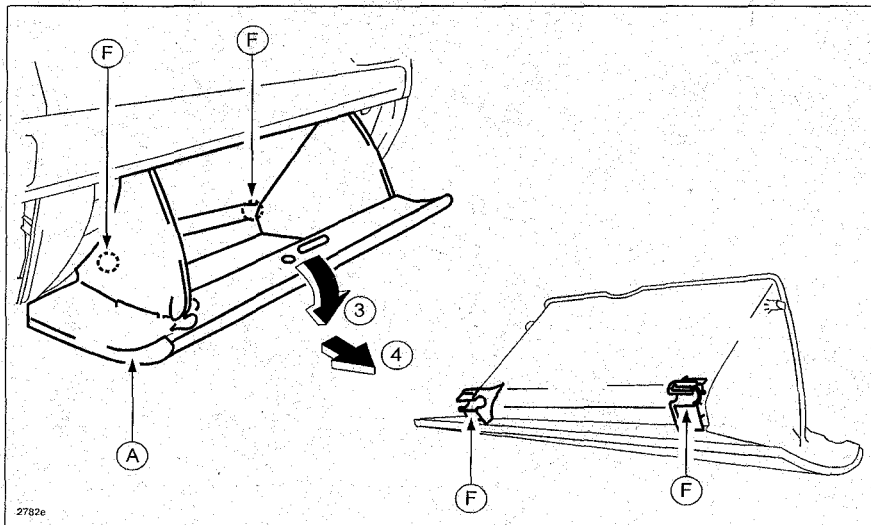

- d. Pull the glove compartment (A) in the direction of the arrow (4) and remove it while detaching hooks (F).

3. Remove the Bluetooth unit nuts (A).
4. Remove the Bluetooth unit (B).

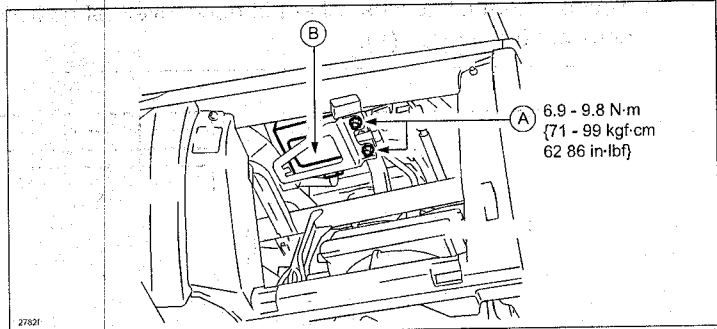

5. Remove the glove box light harness fastener (A).
6. Remove bracket screw (B) and nut (C).
7. Remove bracket (D).

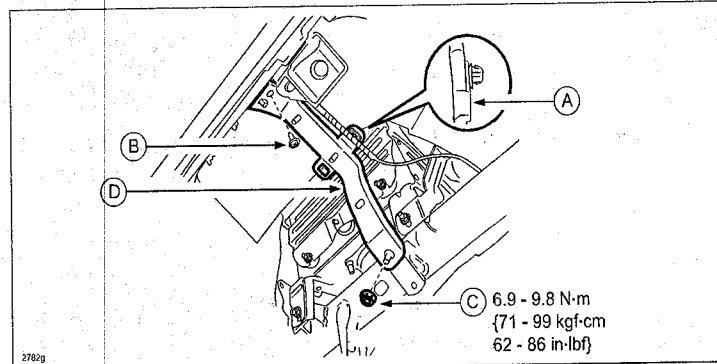

8. Remove bracket nuts (A).

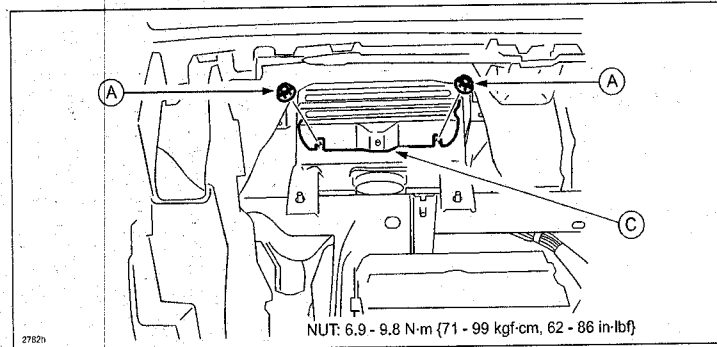

9. Remove bracket (C).

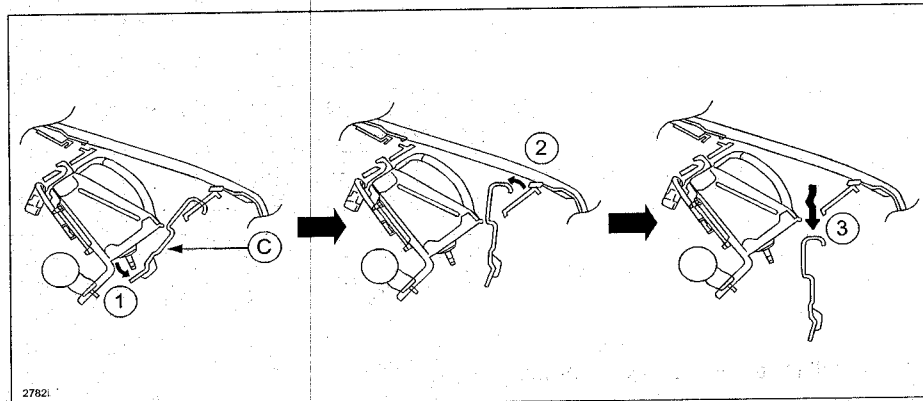

10. Select a 0.25mm thickness sheet of non-woven fabric from the "Noise Parts Set" (P/N TA0-76-100). Cut 9 pieces of 10 X 33 mm (A).

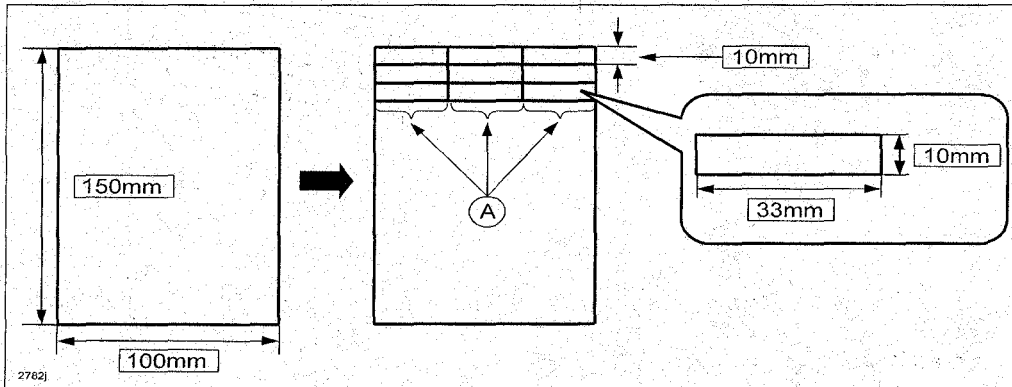

11. Stack three of the 10 X 33 mm non-woven fabric pieces together (total of 0.75mm thickness).

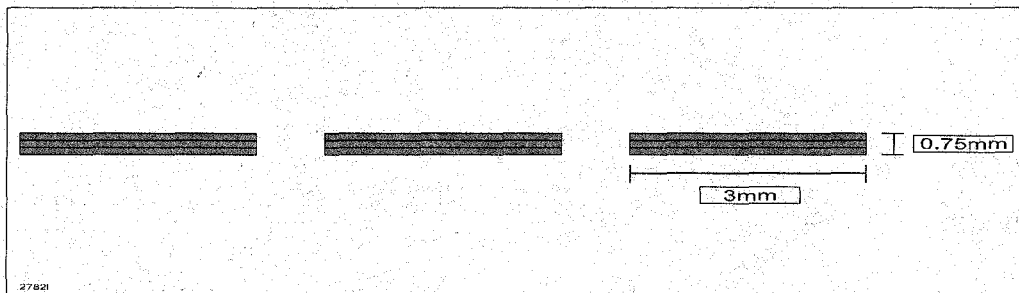

12. Attach the three stacked pieces to the three locations (A) of the bracket as shown below.

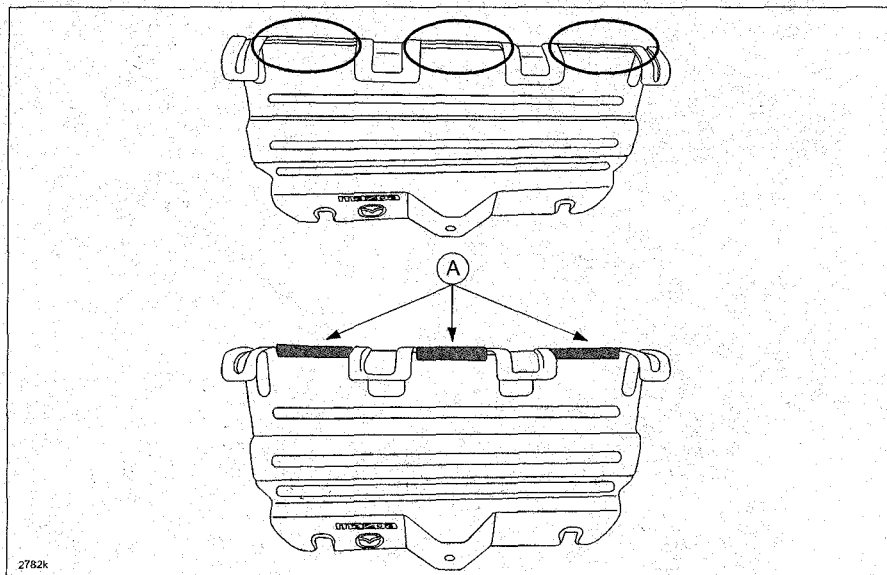

13. Install in reverse order of removal.  
14. Verify repair by lightly tapping on the passenger side of dashboard to confirm the noise is no longer present.

**Bulletin No:** 09-008/13  
© 2013 Mazda Motor of America, Inc.

**Last Issued:** 03/21/2013

### PART(S) INFORMATION

Part Number	Description	Qty.	Notes
TA01-76-100	Noise Parts Set	1	Use 0.25mm thickness non-woven fabric (One sheet can be used for 5 vehicles)

### WARRANTY INFORMATION

**NOTE:**

- This warranty information applies only to verified customer complaints on vehicles eligible for warranty repair.
- This repair will be covered under Mazda's New Vehicle Limited Warranty term.
- Additional diagnostic time cannot be claimed for this repair.

Warranty Type	A
Symptom Code	82
Damage Code	97
Part Number Main Cause	GHP9-57-X11
Quantity	0
Operation Number / Labor Hours:	XXJ3WXRX / 0.3 Hrs.

**NOTE:** Do not claim the noise parts set (P/N TA01-76-100) as a related part. The amount of fabric used for this repair is included in the labor allowance.