

Service Bulletin

Mazda North American Operations
Irvine, CA 92618-2922



© 2013 Mazda Motor of America, Inc.

Subject: WIND NOISE FROM REAR DOOR AREA	Bulletin No: 09-007/13
	Last Issued: 03/13/2013

APPLICABLE MODEL(S)/VINS

2013 CX-5 vehicles with VINs lower than JM3KE*****140662 (produced July 30, 2012)

DESCRIPTION

Some vehicles may exhibit wind noise that occurs from the rear door quarter glass while driving at approx. 25 mph (40Km/h). The noise may be caused by a gap between the rear door quarter glass and the rear door garnish. A soft pad has been attached to the rear door quarter glass guide to eliminate the noise.

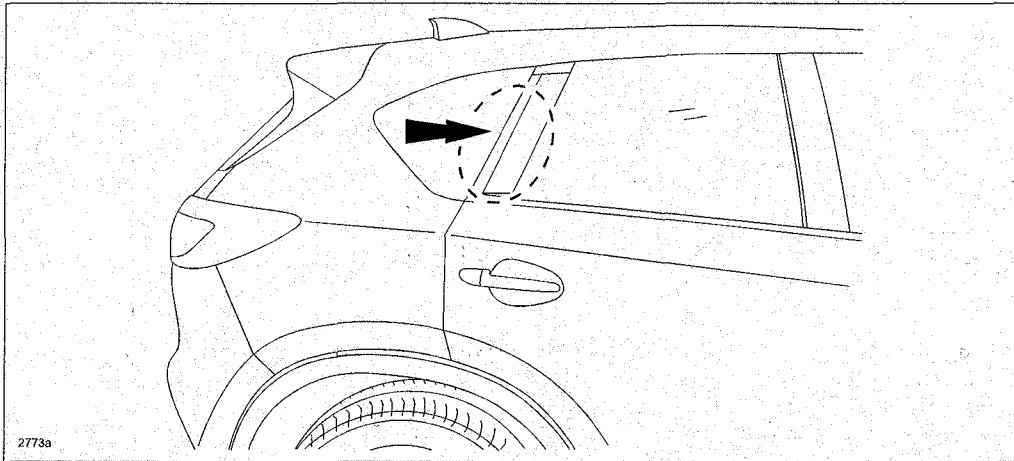

Customers having this concern should have their vehicle repaired using the following repair procedure.

CONSUMER NOTICE: The information and instructions in this bulletin are intended for use by skilled technicians. Mazda technicians utilize the proper tools/equipment and take training to correctly and safely maintain Mazda vehicles. These instructions should not be performed by "do-it-yourselfers." Customers should not assume this bulletin applies to their vehicle or that their vehicle will develop the described concern. To determine if the information applies, customers should contact their nearest authorized Mazda dealership. Mazda North American Operations reserves the right to alter the specifications and contents of this bulletin without obligation or advance notice. All rights reserved. No part of this bulletin may be reproduced in any form or by any means, electronic or mechanical---including photocopying and recording and the use of any kind of information storage and retrieval system ---without permission in writing.

REPAIR PROCEDURE

1. Verify the wind noise occurs by putting masking tape (A) to cover the gap between the rear door quarter glass and the rear door garnish. Test drive the vehicle to verify if the wind noise is gone or not.
 - If the wind noise is gone, proceed to next step of the service bulletin repair procedure.
 - If the wind noise is still present, this repair is not applicable. Proceed to section 09 of MS3 online or the Workshop Manual for additional repair procedures.

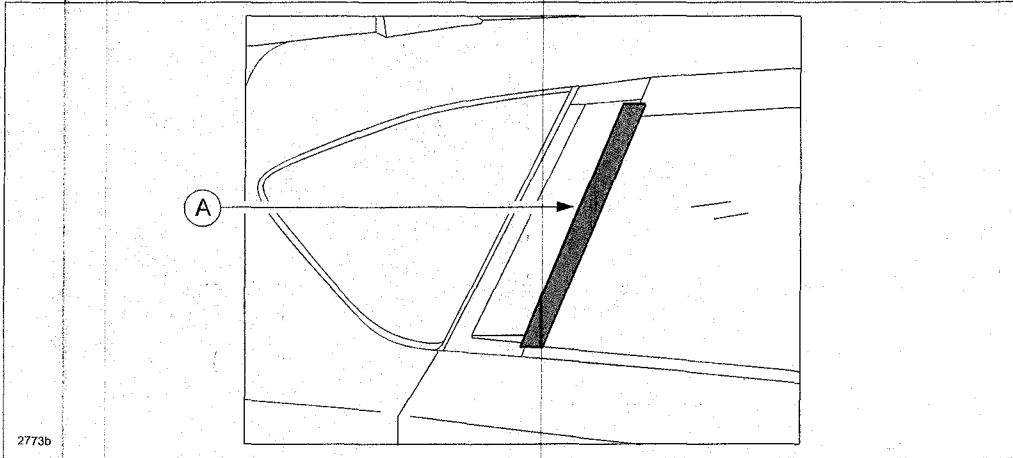

2. Remove the rear door quarter glass and rear door quarter glass guide from the vehicle according to the instructions on MS3 online or the Workshop Manual (section 09-12 REAR DOOR QUARTER GLASS REMOVAL/INSTALLATION).
3. Cut a 5mm x 100mm rectangle from the soft pad.

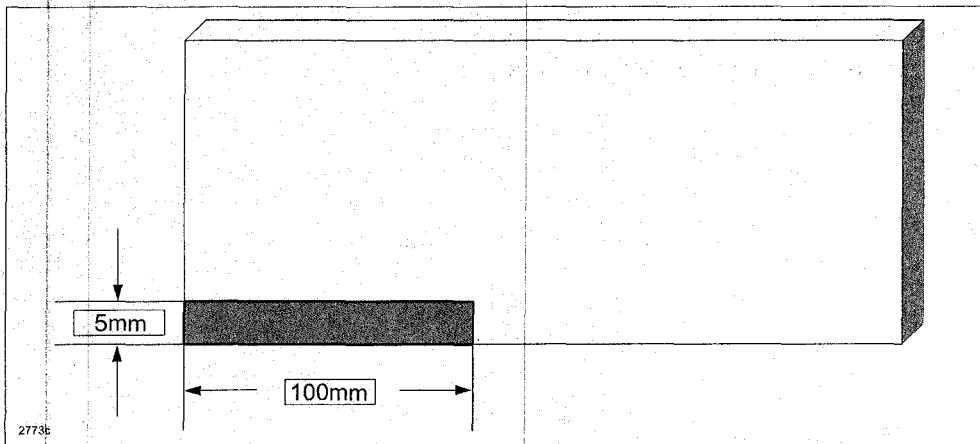

4. Degrease and clean the shaded area of the rear door quarter glass guide (A).
5. Attach the pad (B) in the shaded area.

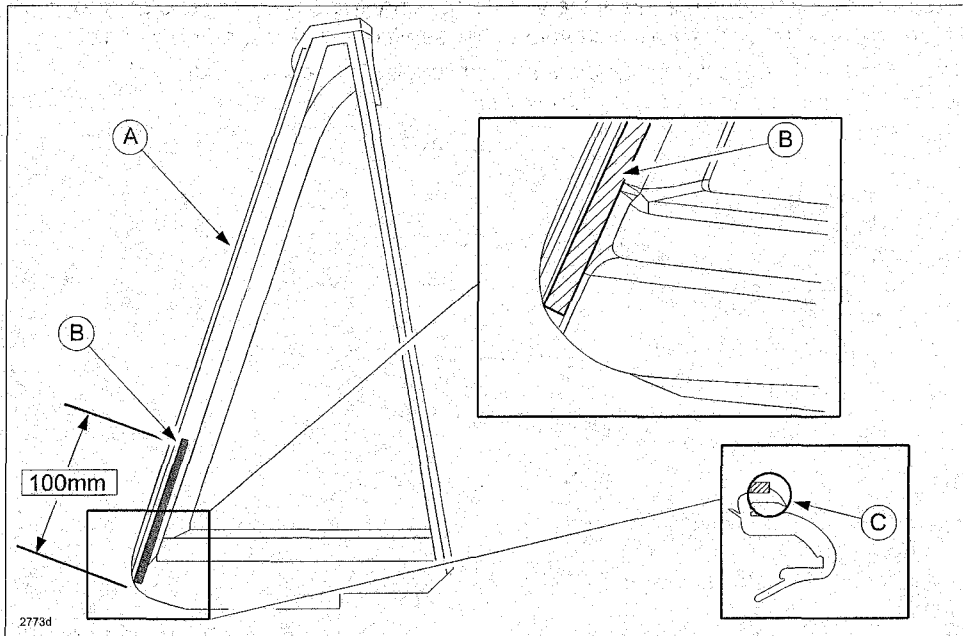

6. Re-install the rear door quarter glass and rear door quarter glass guide to the vehicle according to the instructions on MS3 online or the Workshop Manual (section 09-12 REAR DOOR QUARTER GLASS REMOVAL/INSTALLATION).

NOTE: Avoid gap between pad and wedge lip (C).

7. Test drive the vehicle again to verify the wind noise is gone.

Bulletin No: 09-007/13
© 2013 Mazda Motor of America, Inc.

Last Issued: 03/13/2013

PART(S) INFORMATION

Part Number	Description	Qty.	Notes
NCY1-R1-433	Soft Pad	1	3mm thickness 1 pad repairs approx. 47 vehicles.

WARRANTY INFORMATION

NOTE:

- This warranty information applies only to verified customer complaints on vehicles eligible for warranty repair.
- This repair will be covered under Mazda's New Vehicle Limited Warranty term.
- Additional diagnostic time cannot be claimed for this repair.

Warranty Type	A
Symptom Code	82
Damage Code	9H
Part Number Main Cause	KD53-72-651 (RH) or KD53-73-651 (LH)
Quantity	0
Operation Number / Labor Hours	XXJ3JXRX / 0.4 Hrs. (one side) XXJ3KXRX / 0.7 Hrs. (both sides)

NOTE: Do not attempt claim part number NCY1-R1-433. The cost of the necessary parts (Soft Pad) to be installed for this repair is include in the labor allowance.