

© 2013 Mazda Motor of America, Inc.

Subject: TAPPING NOISE WHERE EDGE OF DASHBOARD MEETS WINDSHIELD	Bulletin No: 09-004/13
	Last Issued: 03/06/2013

APPLICABLE MODEL(S)/VINS

2013 CX-5 vehicles with VINs JM3KE*****122583 ~ 146712 (produced May 6, 2012 ~ Aug. 31, 2012)

DESCRIPTION

Some vehicles may exhibit a tapping noise which is audible from the front edge of the dashboard (A) (where it meets the base of the windshield) when driving over bumps or rough roads.

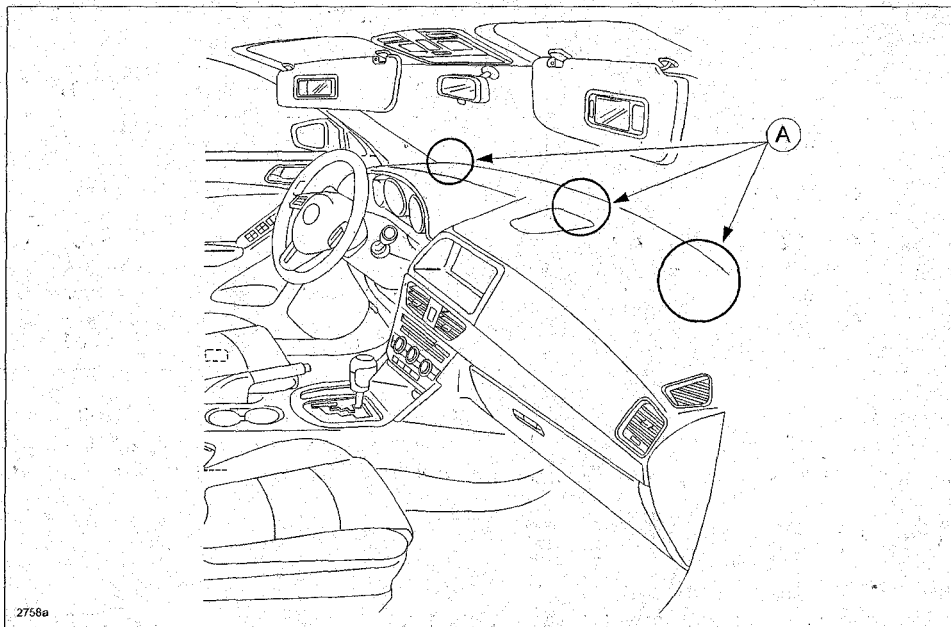

The tapping noise may be caused when the front edge of the dashboard contacts the body-side bracket(s). To eliminate the noise, felt pads have been attached to all (3) three body-side brackets during vehicle mass-production.

Customers having this concern should have their vehicle repaired using the following repair procedure.

CONSUMER NOTICE: The information and instructions in this bulletin are intended for use by skilled technicians. Mazda technicians utilize the proper tools/equipment and take training to correctly and safely maintain Mazda vehicles. These instructions should not be performed by "do-it-yourselfers." Customers should not assume this bulletin applies to their vehicle or that their vehicle will develop the described concern. To determine if the information applies, customers should contact their nearest authorized Mazda dealership. Mazda North American Operations reserves the right to alter the specifications and contents of this bulletin without obligation or advance notice. All rights reserved. No part of this bulletin may be reproduced in any form or by any means, electronic or mechanical---including photocopying and recording and the use of any kind of information storage and retrieval system ---without permission in writing.

REPAIR OVERVIEW:

There are (3) three brackets (left, center and right) on the body-side as shown below (A). A felt pad is attached to each bracket for noise prevention. However, depending on the VIN and production date of the vehicle, felt pads may or may not have been attached to all three brackets. Vehicles without felt pads may experience a tapping noise when driving over bumps or rough roads.

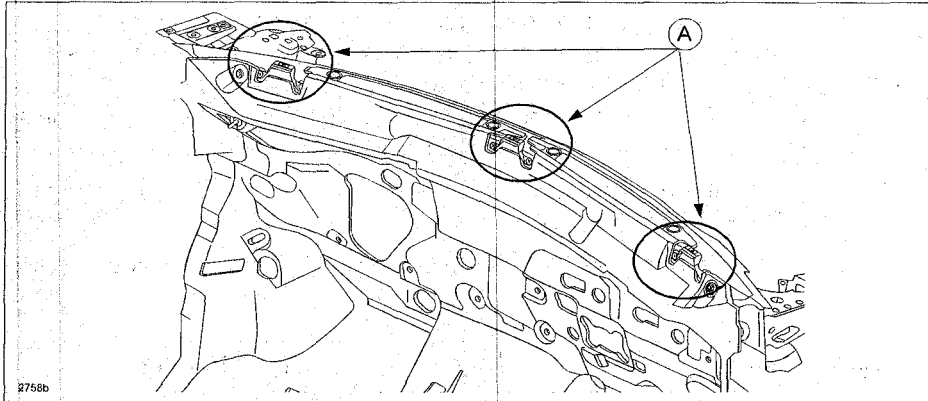

Production date ranges for vehicles with and without felt pads: O = with felt pads, X = without felt pads.

	Vehicle Production Date Range	Body-Side Brackets		
		Left (C)	Center (B)	Right (A)
Vehicle OK	May 5, 2012 or before	O	O	O
Type A Vehicle - Not OK	May 6, 2012 ~ Aug. 20, 2012	X	X	X
Type B Vehicle - Not OK	Aug. 21, 2012 ~ Aug. 31, 2012	O	X	O
Vehicle OK	Sept. 1, 2012 or after	O	O	O

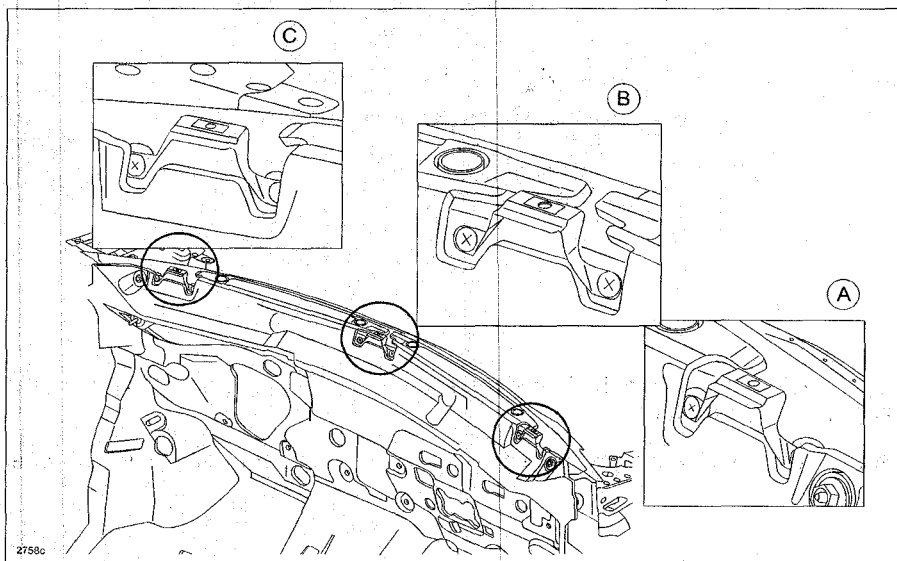

REPAIR PROCEDURE

1. Verify the noise occurs while driving the vehicle over a bump or rough road. Also, verify that the noise stops when lightly pressing the front edge of the dashboard by hand.

NOTE:

- Since the repair involves removal and installation of the windshield, be sure to verify the noise is coming from the front edge of the dashboard before beginning this repair.
 - Keep in mind that TSB 09-009/12 - "2013 CX-5 - RATTLE NOISE FROM INSTRUMENT PANEL AND/OR CREAK NOISE FROM A-PILLAR OVER ROUGH / BUMPY ROADS" was also released to address noise concerns around similar locations of the vehicle. Be sure to distinguish the noises from one another and refer to the appropriate TSB to repair the vehicle.
2. Remove the windshield from the vehicle according to the instructions on MS3 online or the Workshop Manual (section 09-12 WINDSHIELD REMOVAL).
 3. Using the table below, determine if the subject vehicle is a Type A Vehicle or a Type B Vehicle.

Type A Vehicle	Type B Vehicle
Production Date Range: May 6, 2012 ~ Aug. 20, 2012	Production Date Range: Aug. 21, 2012 ~ Aug. 31, 2012
VIN: JM3KE*****122583 ~ 144011	VIN: JM3KE*****144012 ~ 146712
Repair: Attach a felt pad on all (3) three brackets (left, center and right).	Repair: Attach a felt pad on the center bracket only.

4. While lifting up the edge of the dashboard and holding it up by hand, attach the felt pads (A) on the brackets. Wrap the pad around the edges of the bracket as shown below (B).
 - For Type A Vehicles, attach a felt pad on all (3) three brackets (left, center and right).
 - For Type B Vehicles, attach a felt pad on the center bracket only.

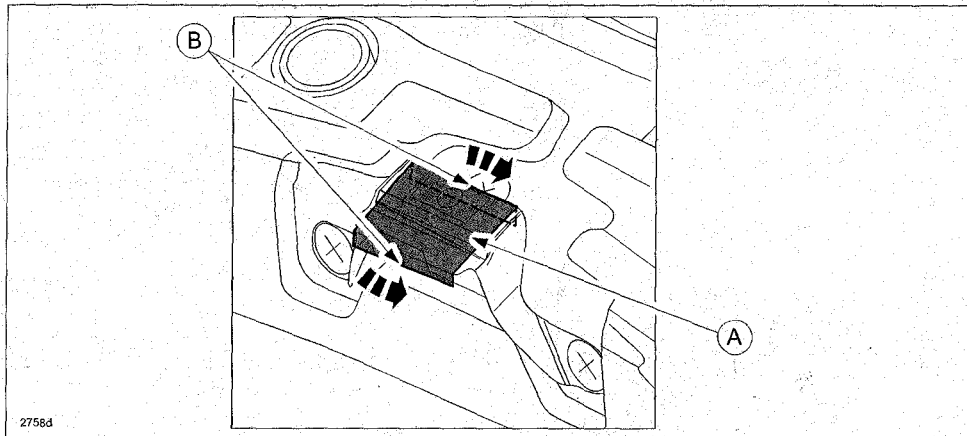

5. Re-install the windshield according to the instructions on MS3 online or the Workshop Manual (section 09-12 WINDSHIELD INSTALLATION).

NOTE: The A-pillar trim clips cannot be reused, so replace them (both sides) with new ones.

6. Verify repair.

PART(S) INFORMATION

Part Number	Description	Qty.	Notes
KD45-55-169	Felt Pad	1 or 3	Type A Vehicle = Qty. 3 pads Type B Vehicle = Qty. 1 pad
D651-68-162A	A-Pillar Trim Clip	2	For both sides. Old clips cannot be reused

WARRANTY INFORMATION

NOTE:

- This warranty information applies only to verified customer complaints on vehicles eligible for warranty repair.
- This repair will be covered under Mazda's New Vehicle Limited Warranty term.
- Additional diagnostic time cannot be claimed for this repair.

	Dealer Removes Windshield	Dealer sublets windshield removal to glass company
Warranty Type	A	A
Symptom Code	91	91
Damage Code	97	97
Part Number Main Cause	KD45-55-169	KD45-55-169
Quantity	3 - (Type A Vehicle) 1 - (Type B Vehicle)	3 - (Type A Vehicle) 1 - (Type B Vehicle)
Operation Number / Labor Hours	XXJ1EXRX / 2.7 Hrs.	XXJ1EARX / 0.3 Hrs.
Windshield Sublet to Glass Shop:		
Sublet Invoice Number	---	Invoice Number from Glass Shop or Dealer Purchase Order
Sublet Type Code	---	Enter D1 (Glass labor only to repair glass)
Sublet Amount	---	Enter amount of sublet (Not to exceed dealer labor rate times 2.4 hours)
Sublet Text	---	Sublet to remove and reinstall windshield

NOTE:

- Windshield breakage is not covered under warranty.
- Enter A-pillar trim clips as related parts.