

# Service Bulletin

Mazda North American Operations  
Irvine, CA 92618-2922



© 2013 Mazda Motor of America, Inc.

<b>Subject:</b>  DRIVER-SIDE POWER DOOR MIRROR VIBRATION	<b>Bulletin No:</b> 09-002/13
	<b>Last Issued:</b> 02/26/2013

## APPLICABLE MODEL(S)/VINS

2013 CX-5 vehicles with VINs lower than JM3KE\*\*\*\*\*168885 (produced before November 16, 2012)

## DESCRIPTION

Some vehicles may exhibit a vibration from the driver-side power door mirror glass when the vehicle is driven at high speeds.

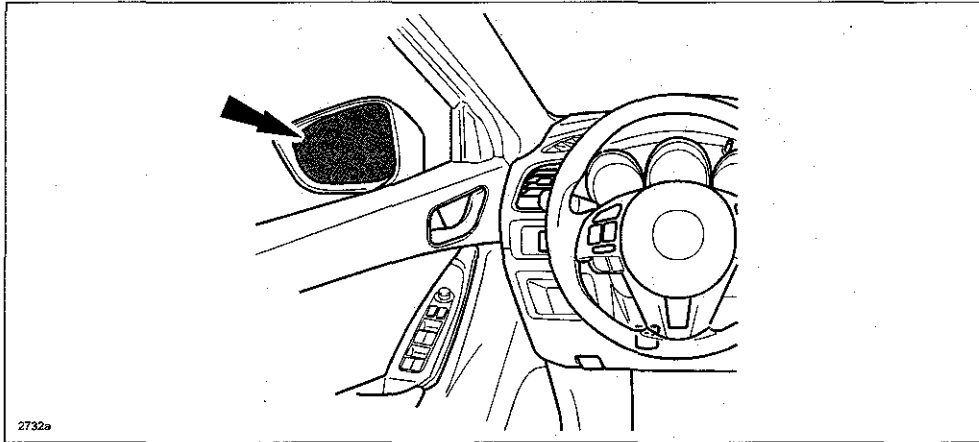

This concern may be due to a lack of rigidity of the mirror base so the mirror vibrates when it receives vehicle vibration or wind pressure.

Customers having this concern should have their vehicle repaired using the following repair procedure.

**CONSUMER NOTICE:** The information and instructions in this bulletin are intended for use by skilled technicians. Mazda technicians utilize the proper tools/equipment and take training to correctly and safely maintain Mazda vehicles. These instructions should not be performed by "do-it-yourselfers." Customers should not assume this bulletin applies to their vehicle or that their vehicle will develop the described concern. To determine if the information applies, customers should contact their nearest authorized Mazda dealership. Mazda North American Operations reserves the right to alter the specifications and contents of this bulletin without obligation or advance notice. All rights reserved. No part of this bulletin may be reproduced in any form or by any means, electronic or mechanical—including photocopying and recording and the use of any kind of information storage and retrieval system—without permission in writing.

## REPAIR PROCEDURE

**Repair A:** Install a new reinforcement (A) onto the side impact bar-lower (B) and door panel to increase rigidity of the door panel where the power door mirror is located.

**Repair B:** Replace the power door mirror (C) with a modified one.

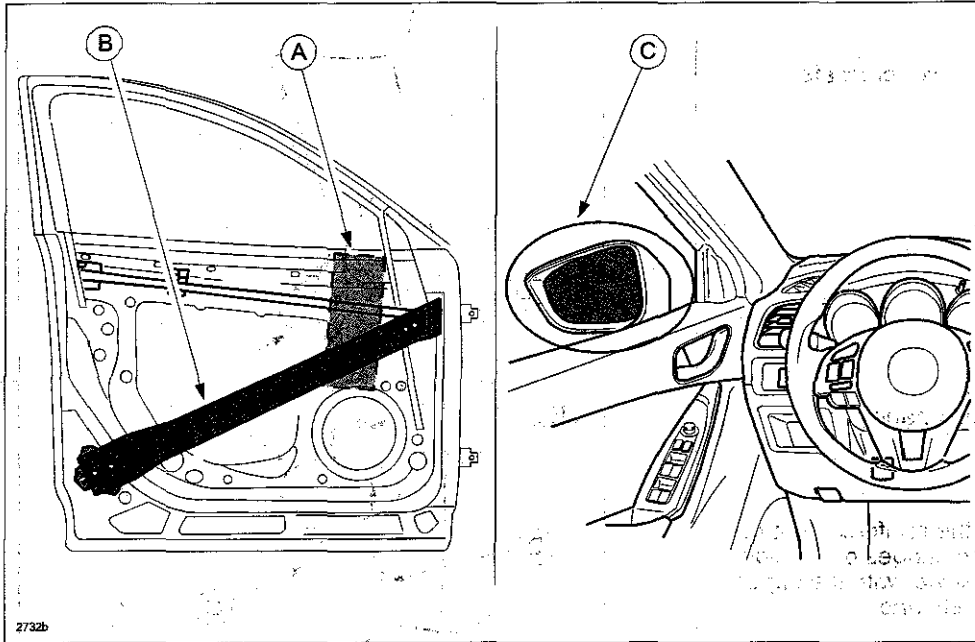

### Outline of Repair A:

**Upper reinforcement:** Tighten the upper reinforcement (A) to the door panel together with the power door mirror with three (3) nuts.

**Lower reinforcement:** Attach the lower reinforcement (B) to the side impact bar-lower with two (2) (upper and lower) brackets.

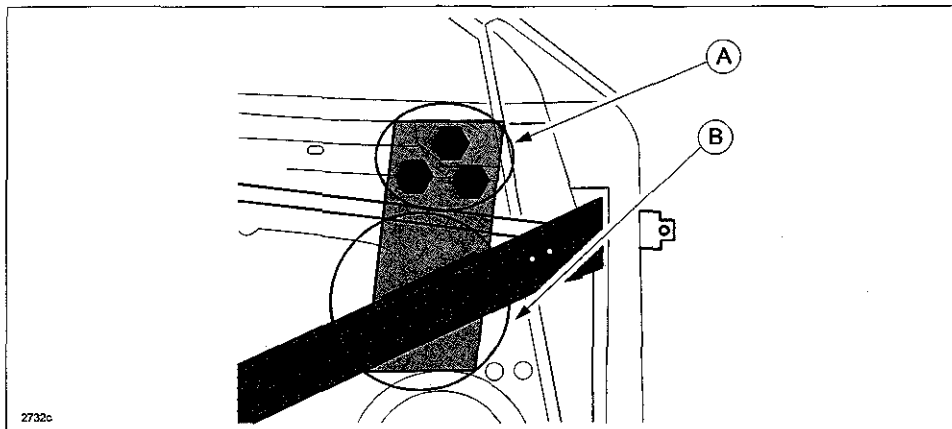

<cross-section>

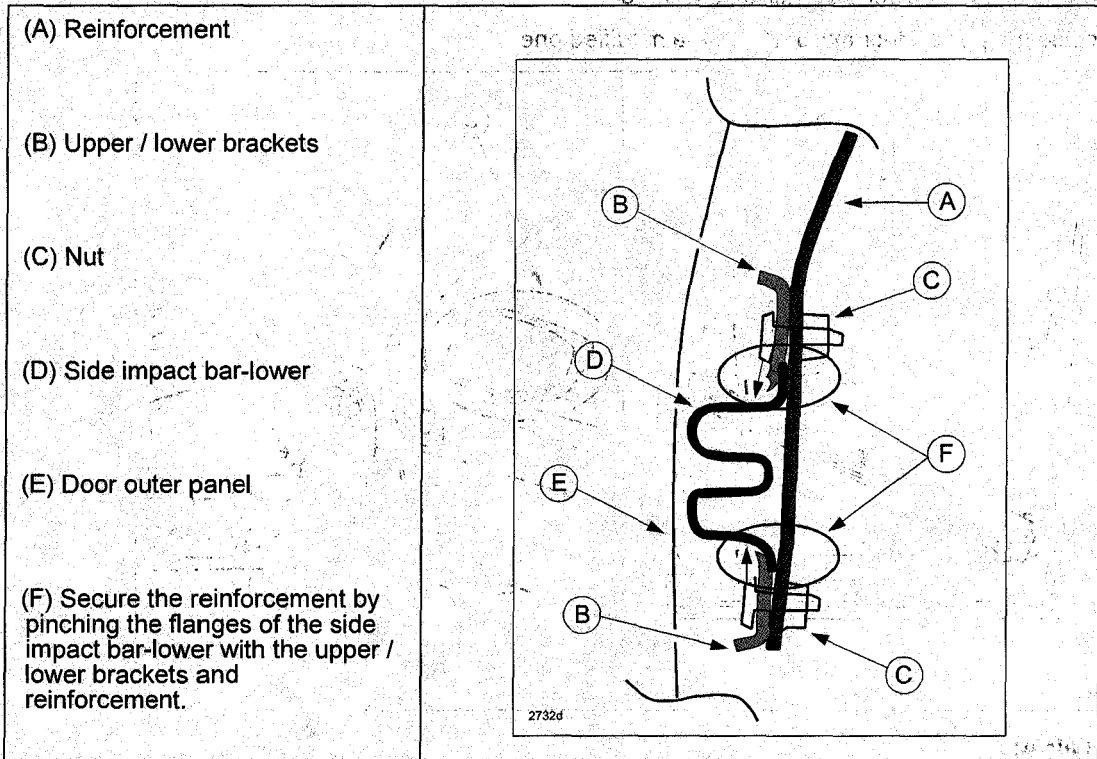

**Outline of Repair B:**

1. Remove the front door module panel (A) according to the instructions on MS3 online or the Workshop Manual (section 09-11 FRONT DOOR MODULE PANEL REMOVAL/INSTALLATION).

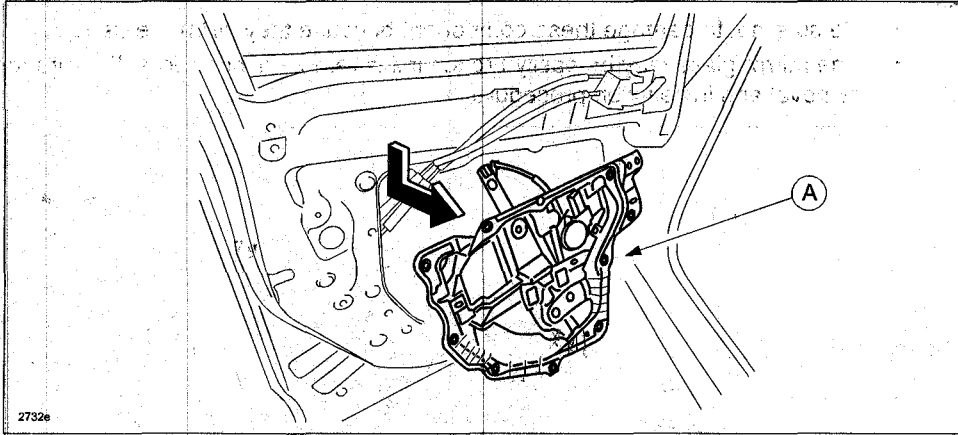

2. Remove the power door mirror (A) according to the instructions on MS3 online or the Workshop Manual (section 09-12 POWER OUTER MIRROR REMOVAL/INSTALLATION).

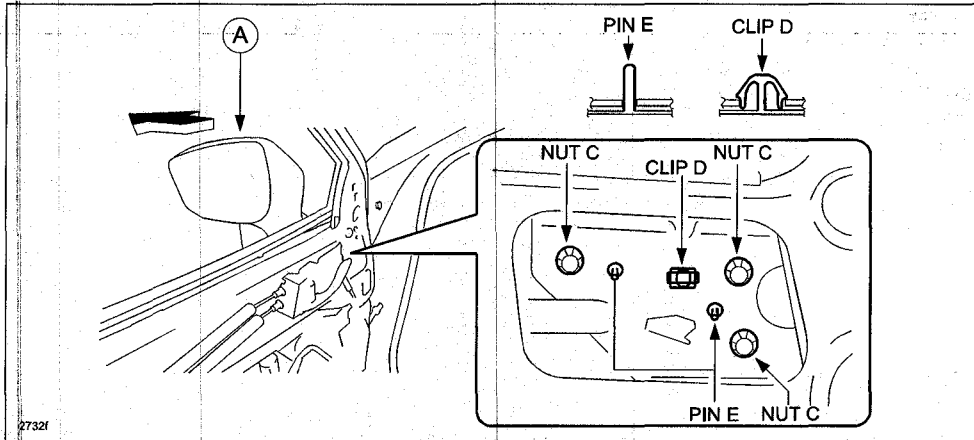

3. Remove the mirror glass (A), garnish (B) and side turn lamp (C) from the removed outer door mirror according to the instructions on MS3 online or the Workshop Manual (section 09-12 OUTER MIRROR GARNISH REMOVAL/INSTALLATION) and (section 09-18 SIDE TURN LIGHT REMOVAL/INSTALLATION).

**CAUTION:**

- Be sure not to damage these component because they will be re-used.
- The mirror glass may be easily broken if it is removed incorrectly. Be sure to follow the removal and installation procedure.

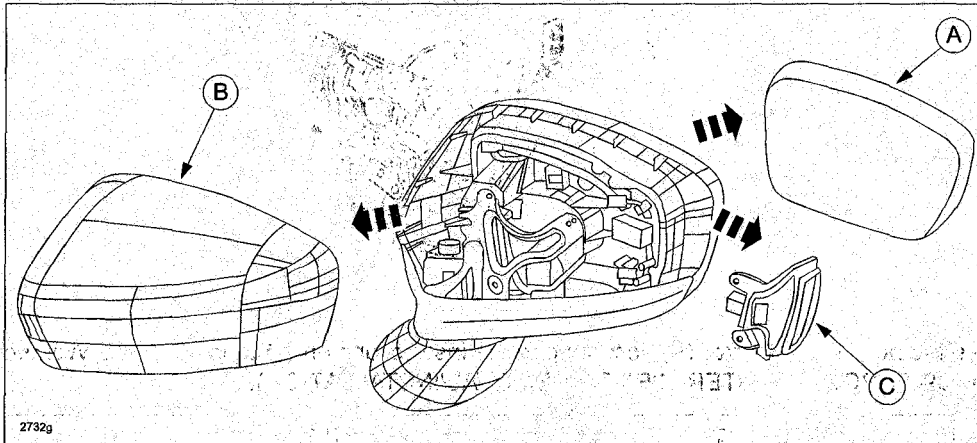

**Construction of Mirror Glass and Base:**

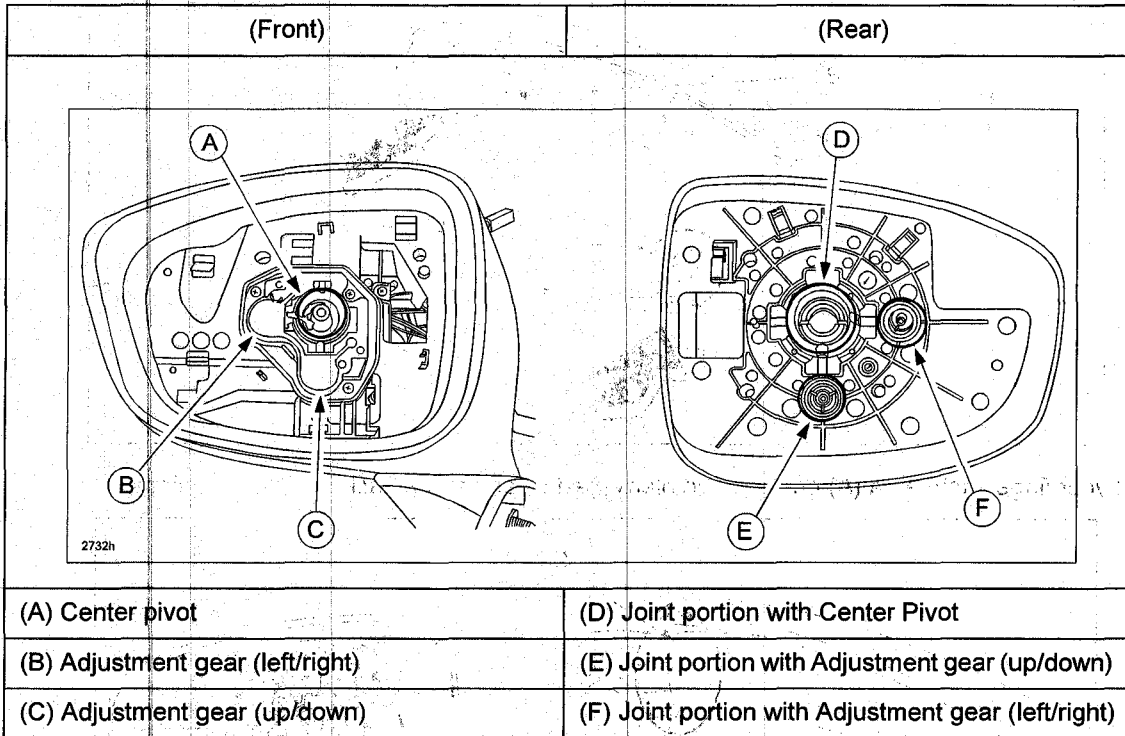

**Removal:**

1. In order to make it easier to disconnect the joint portion with the center pivot, heat the center of the mirror glass with a drier to approx. 104-122 degrees F (40-50 degrees C).

**CAUTION:** Be sure not to use too much heat, otherwise the mirror could become deformed.

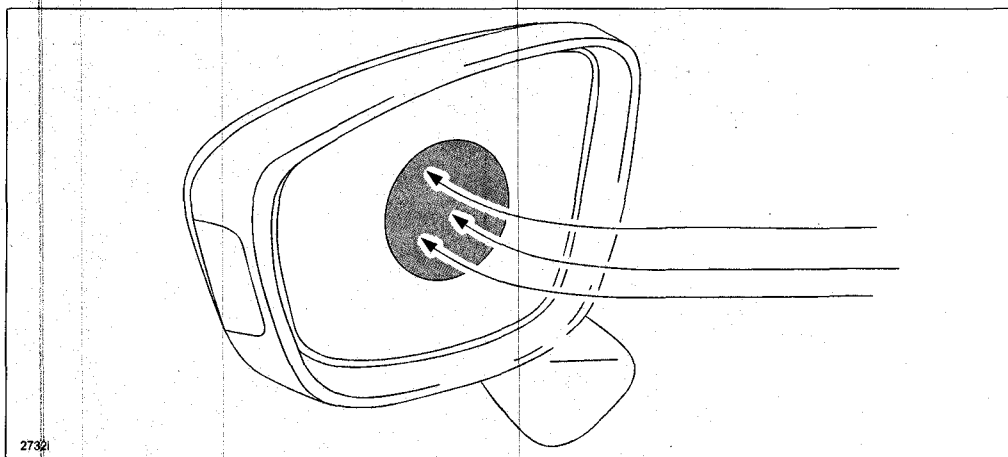

2. In order to make a space for your fingers to insert in the back of the mirror glass, push area (A) to move area (B) toward you.

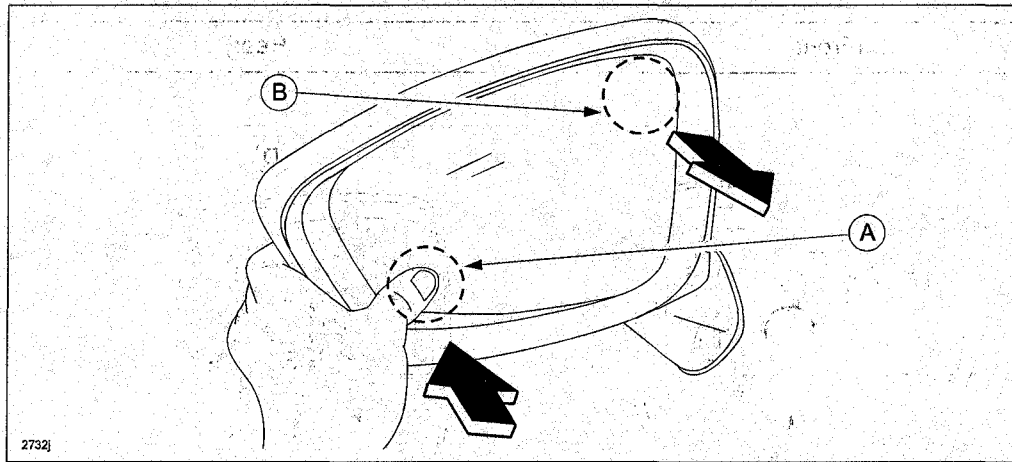

3. Insert your fingers into area (A) between the black plastic base at the back of the mirror glass.

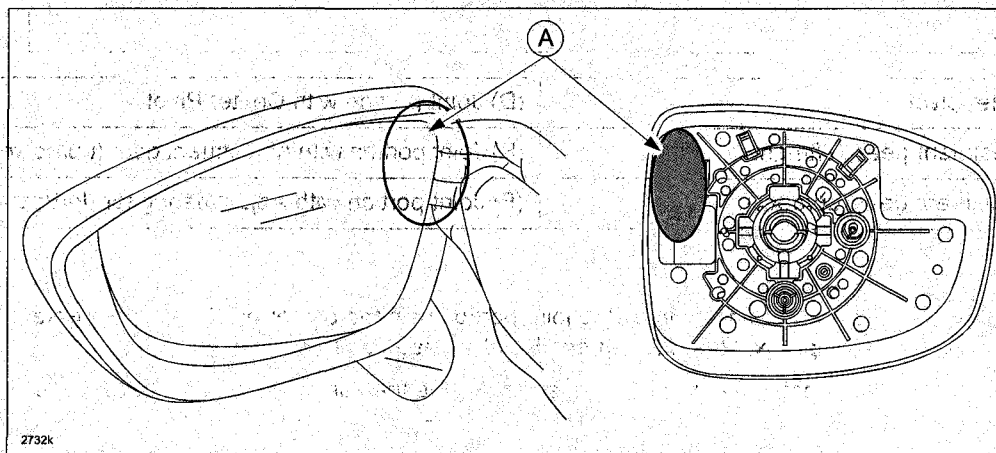

4. Press the black plastic base at the back of mirror glass (A) toward you and carefully disconnect the joint with the center pivot (B).

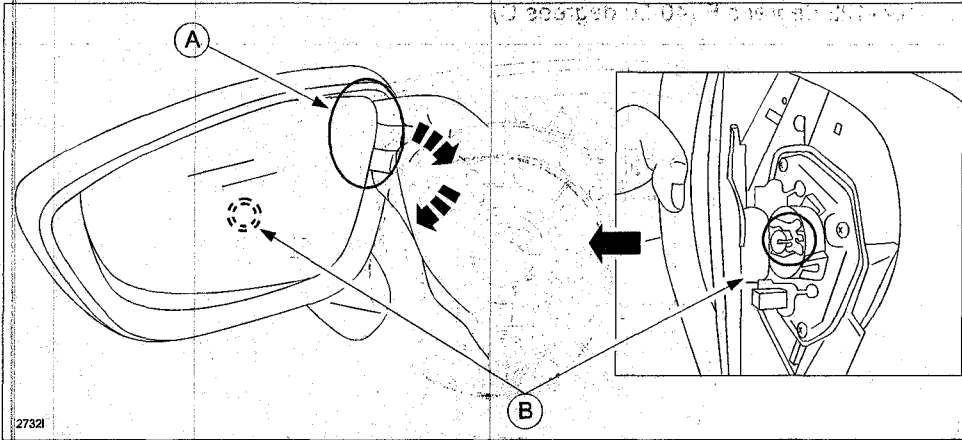

5. Move the mirror glass left and right and up and down to make a space for your fingers to insert in the back of mirror glass. Press the mirror glass with your fingers toward you to disconnect the joint for adjustment gears (A) and (B).

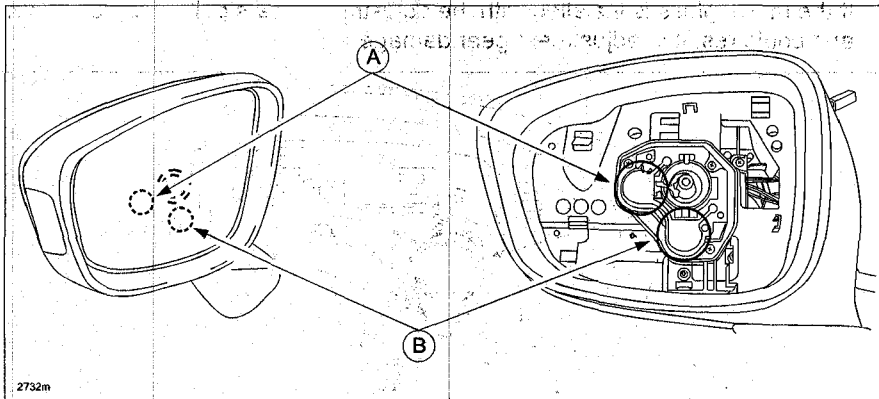



**Installation:**

1. In order to make it easier to connect the joints, heat the plastic base at the back of mirror glass with a drier to approx. 104-122 degrees F (40-50 degrees C).

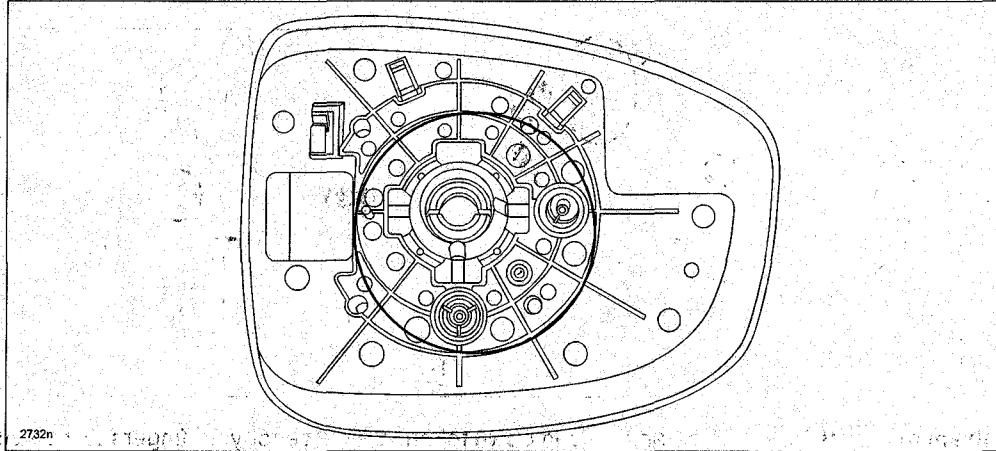

2. Push the adjustment gears (A) and (B) all the way down.

**CAUTION:** If the mirror glass is installed with the adjustment gears pulled up, force is not applied straight and could result in adjustment gear damage.

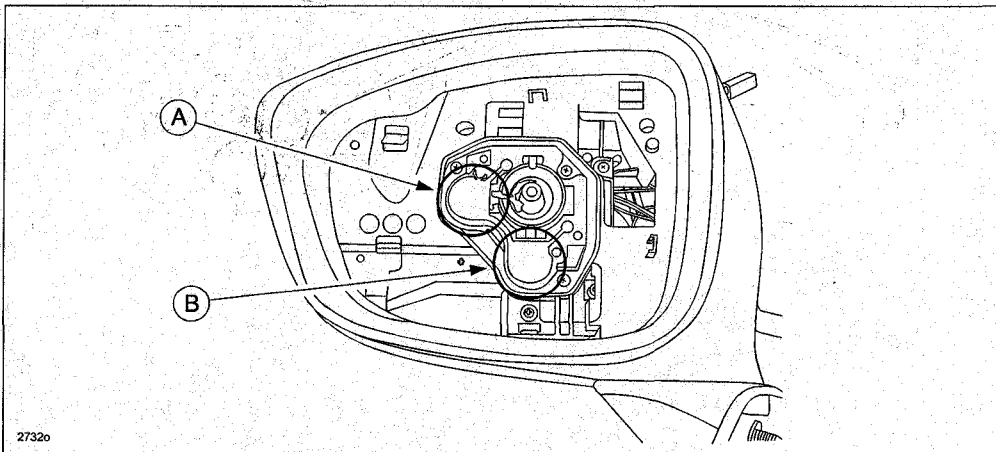

3. Place the mirror glass on the mirror base aligning the location of the center pivot (A).

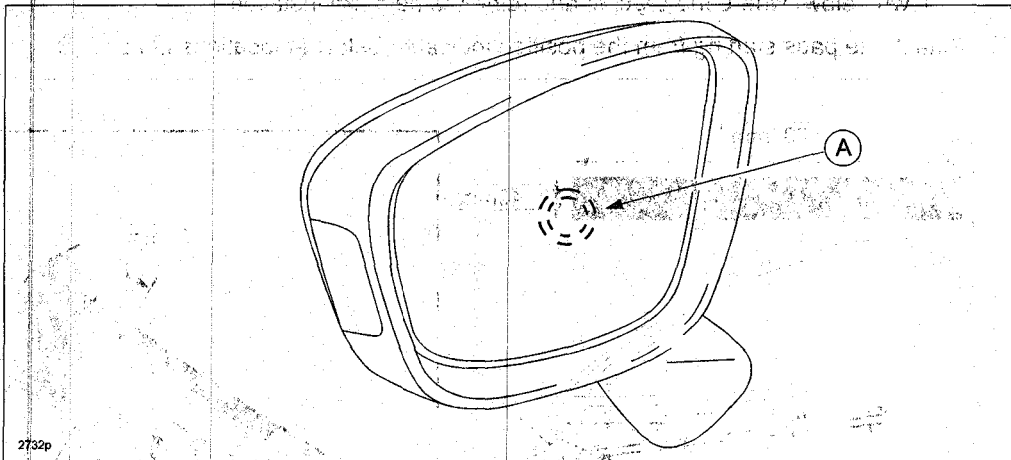

4. Gradually press the center of the mirror glass with your palm to click in the center pivot.
5. Press the areas (A) and (B) of the mirror glass to click in the joint for the adjustment gears.

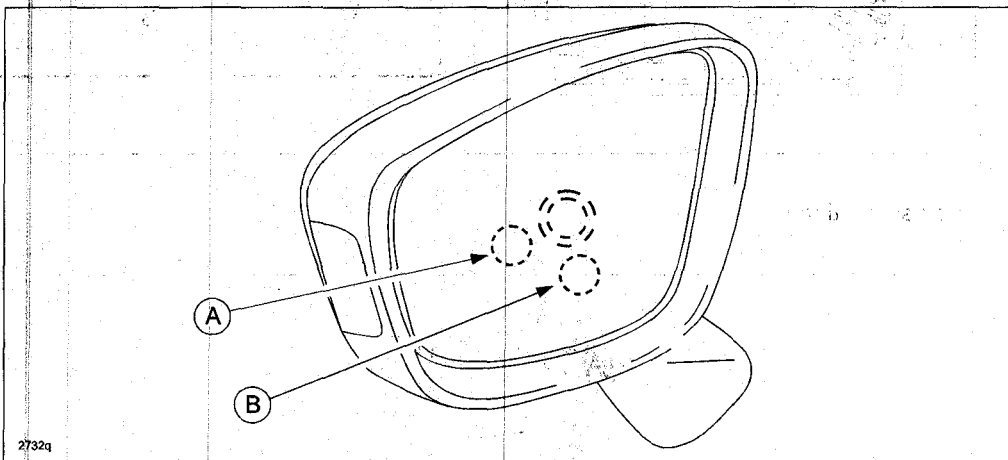

6. Move the mirror glass up and down and left and right to verify that the adjustment gears move smoothly and without any problem.
7. Adjust the mirror glass in the neutral position.
8. Install the removed side turn lamp, garnish and glass onto the new power door mirror.

9. For rust prevention, attach two (2) self-stick pads (200mm x 40mm) to each edge of the side impact bar-lower (as shown below) where the bracket and reinforcement are installed.

**NOTE:** Attach the pads starting from the position indicated below at locations (A) and (B).

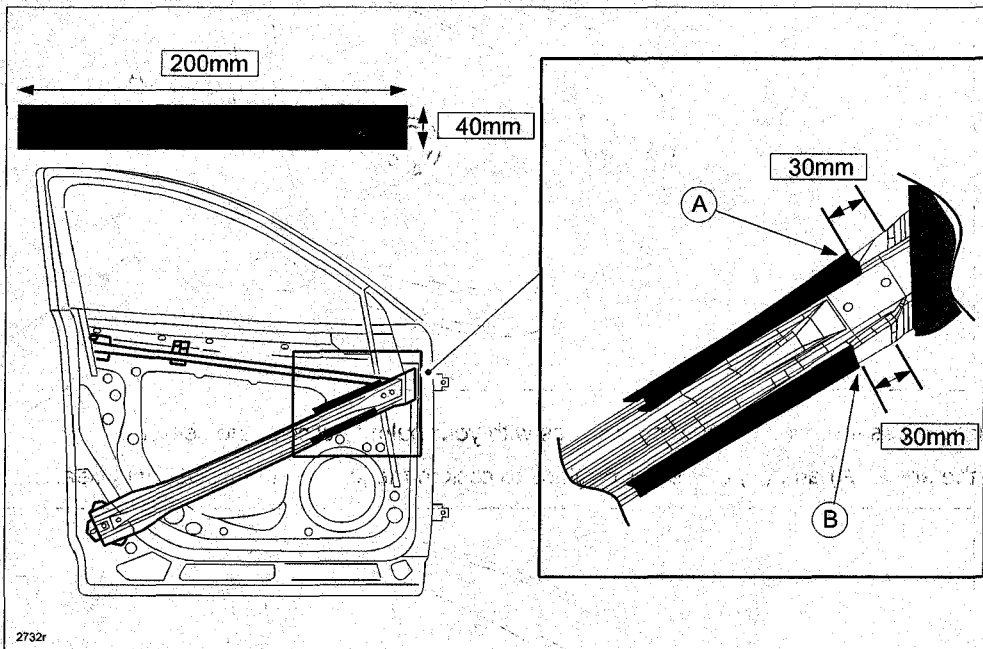

<cross-section>

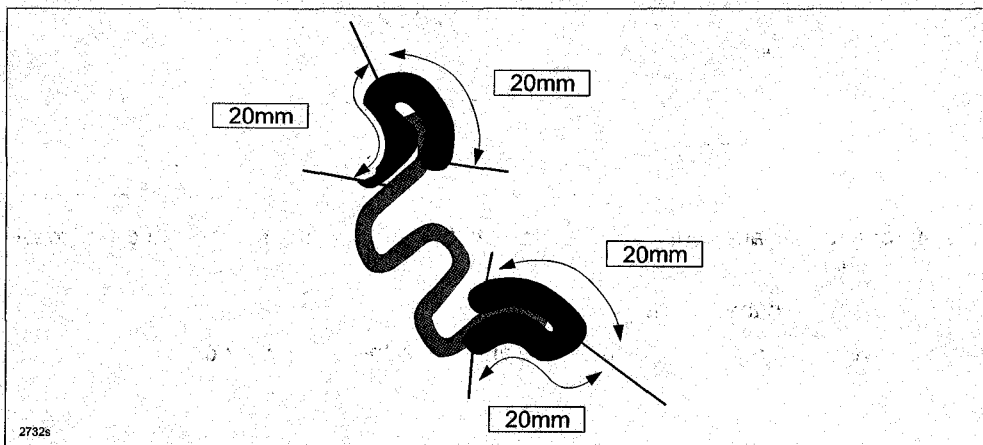

10. Install the reinforcement (A) as shown below. Secure the upper part (B) together with the power door mirror and the lower part (C) to the side impact bar-lower with the two (2) brackets:

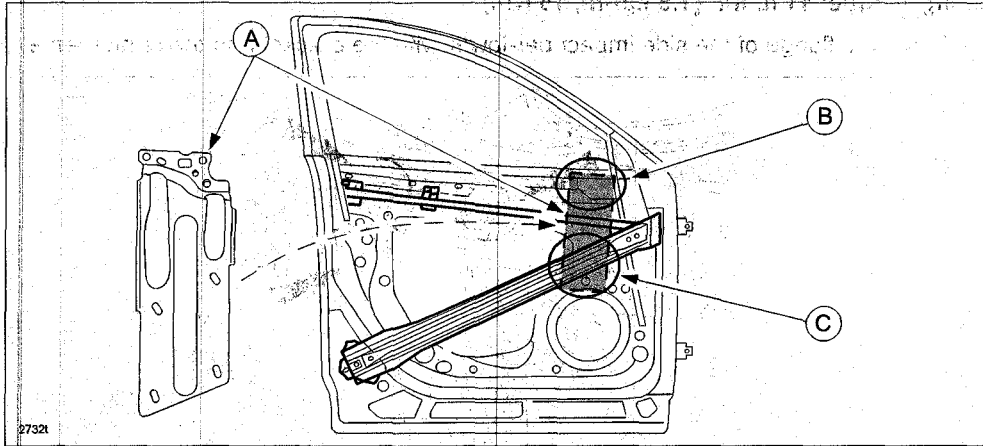

11. Temporarily fit the new power door mirror onto the door, but do not tighten it at this time.

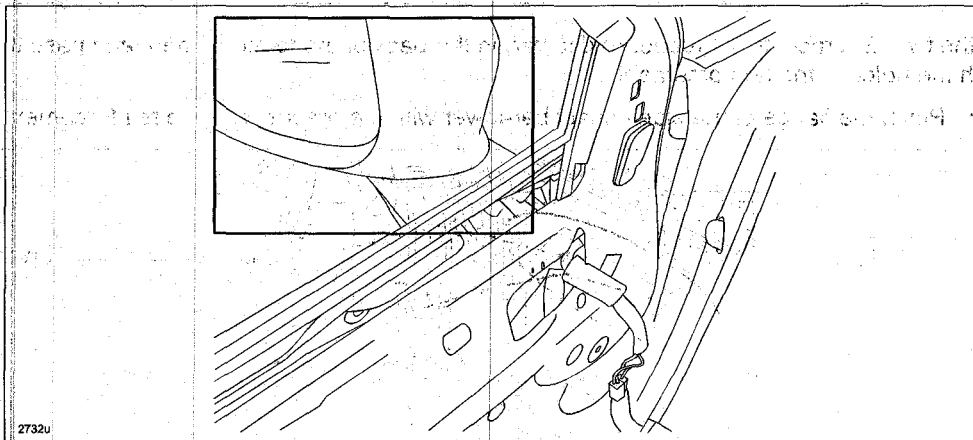

12. While holding the power door mirror, place the reinforcement passing three (3) stud bolts of the power door mirror through the holes in the reinforcement and tighten the three (3) nuts.  
**Tightening Torque: 11 ft. lbf. {1.5 kgf-m, 15 Nm}**

**NOTE:** Pinch the flange of the side impact bar-lower with the bracket and the reinforcement.

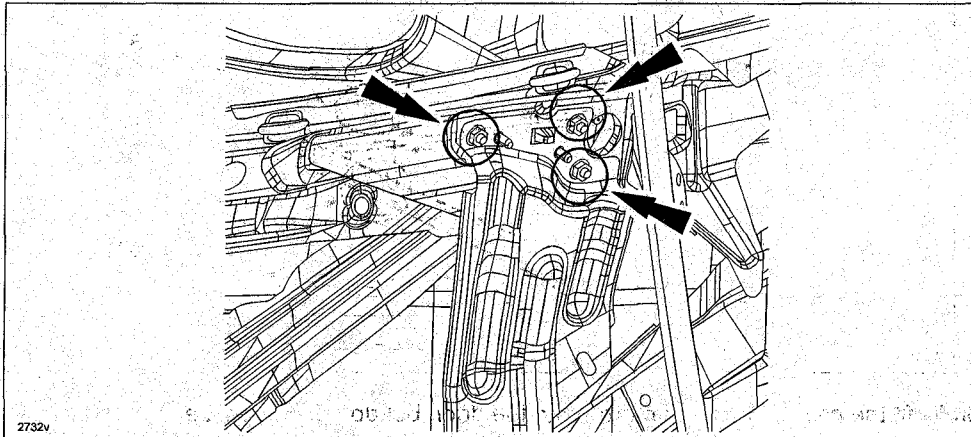

13. Place the two (2) brackets (A) (upper and lower) in the back of the reinforcement and pass the stud bolts through the holes in the reinforcement.

**NOTE:** Pinch the flange of the side impact bar-lower with the bracket and the reinforcement.

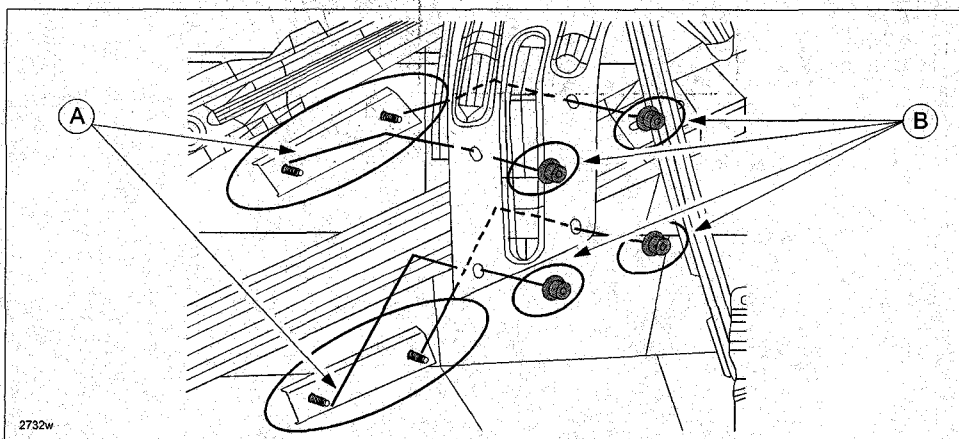

14. Tighten the four (4) nuts (B) to secure the reinforcement onto the side impact bar-lower.  
**Tightening Torque: 15 ft. lbf. {2.1 kgf-m, 20 Nm}**

**NOTE:**

- Tighten the brackets so that the side impact bar-lower is pushed toward the direction of the arrow.
- Ensure that each part does not touch petal to petal face or it will cause rust occurrence.

<cross-section>

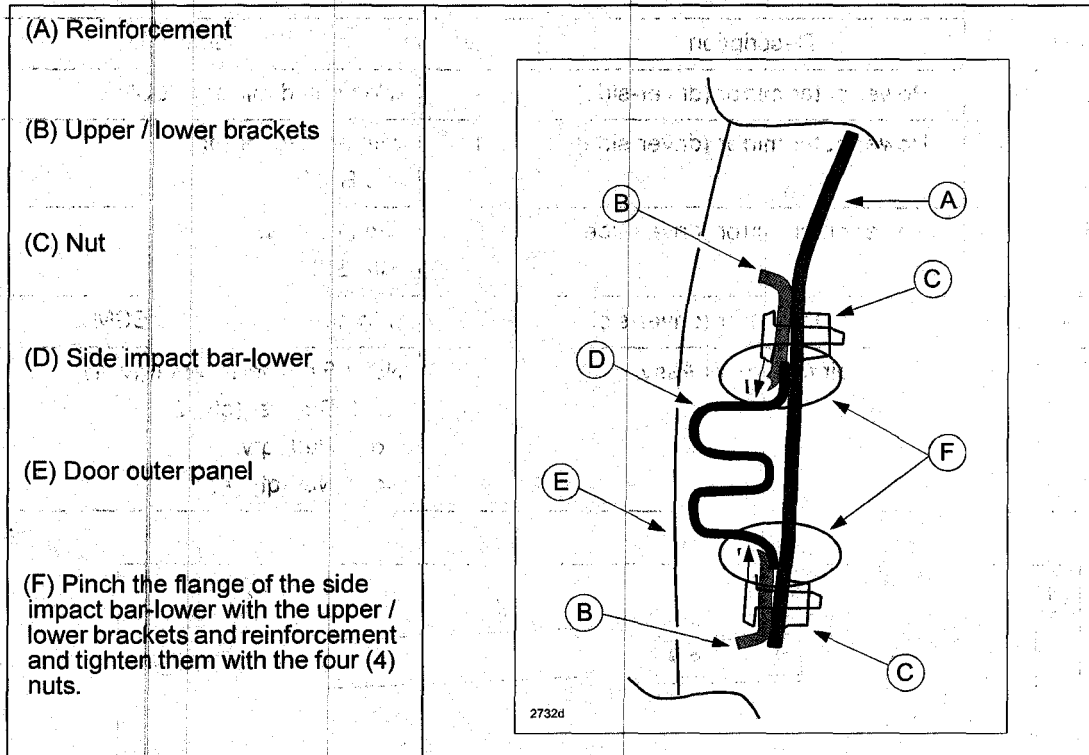

15. Install other removed parts in the reverse order of removal.

16. Verify the repair.

**PART(S) INFORMATION**

Part Number	Description	Qty.	Notes
KDY0-69-181	Power outer mirror (driver-side)	1	w/o heated mirror or BSM
KDY1-69-181	Power outer mirror (driver-side)	1	with heated mirror w/o BSM
KDY2-69-181	Power outer mirror (driver-side)	1	w/o heated mirror with BSM
KDY3-69-181	Power outer mirror (driver-side)	1	with heater mirror and BSM
KDY0-59-050	Reinforcement Assy.	1	No. 1 Reinforcement (qty. 1) No. 2 Bracket (qty. 2) No. 3 Pad (qty. 2) No. 4 Nut (qty. 4)

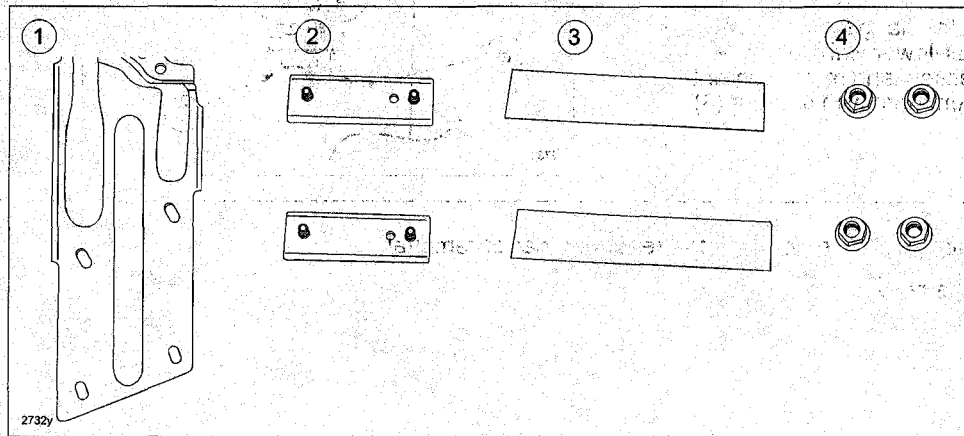

Bulletin No. 09-002/13  
© 2013 Mazda Motor of America, Inc.

Last Issued: 02/26/2013

## WARRANTY INFORMATION

### NOTE:

- This warranty information applies only to verified customer complaints on vehicles eligible for warranty repair.
- This repair will be covered under Mazda's New Vehicle Limited Warranty term.
- Additional diagnostic time cannot be claimed for this repair.

Warranty Type	A
Symptom Code	83
Damage Code	97
Part Number Main Cause	KDY0-69-181 or KDY1-69-181 or KDY2-69-181 or KDY3-69-181
Quantity	1
Operation Number / Labor Hours:	XXJ1HXRX / 0.8 Hrs.