



Service Bulletin

File in Section: 08 - Body and Accessories

Bulletin No.: 08-08-110-001G

Date: May, 2013

TECHNICAL

Subject: Folding Top Headliner Wear (Remove Sharp Edges, Replace Pins/Retainers and Headliner)

Models: 2005-2013 Chevrolet Corvette Convertible

This bulletin is being revised to add the 2013 model year and update Condition, Cause and Correction #1 information. Please discard Corporate Bulletin Number 08-08-110-001F (Section 08 – Body and Accessories).

Condition #1

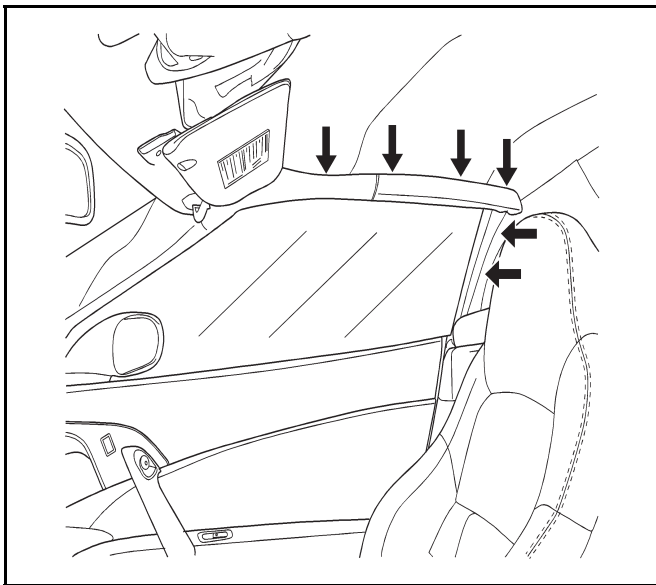

2038820

Some customers may comment that the headliner has some wear damage on the outer edges along the upper trim.

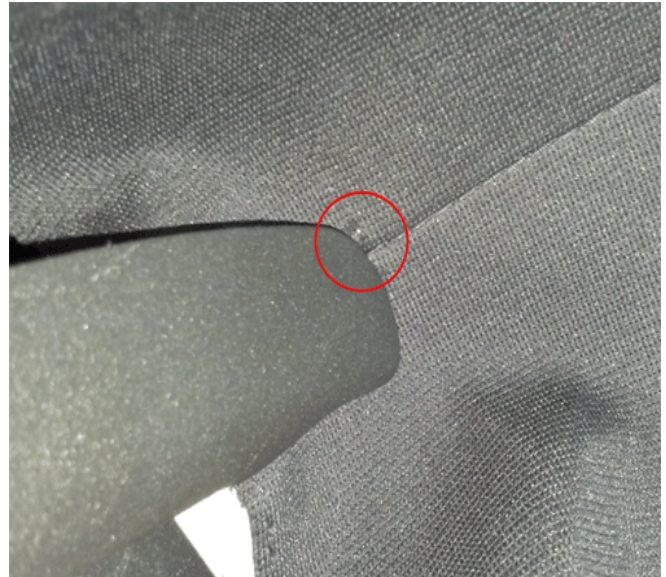

3446265

In some unique cases, the wear damage may be specific to the left or right upper B-pillar area.

Cause #1

This condition may be most commonly caused by a sharp edge on the outer headliner trim, which causes wear during the cycling of the folding top.



3446273

In less common cases, where the damage may be specific to the left or right upper B-pillar area, the cause may be interference of the upper side roof rail to the #3 bow plastic insert. This interference is shown circled in the graphic above.

Correction #1

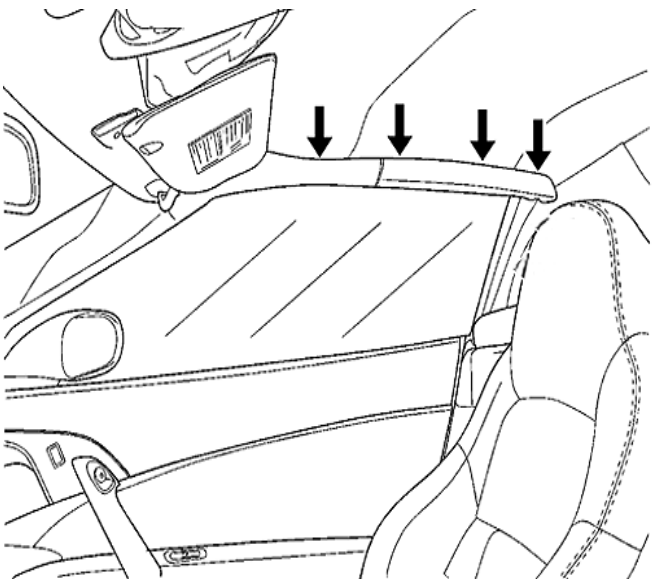

3453578

1. Remove the damaged headliner and round off the inner top edge of the headliner trim.

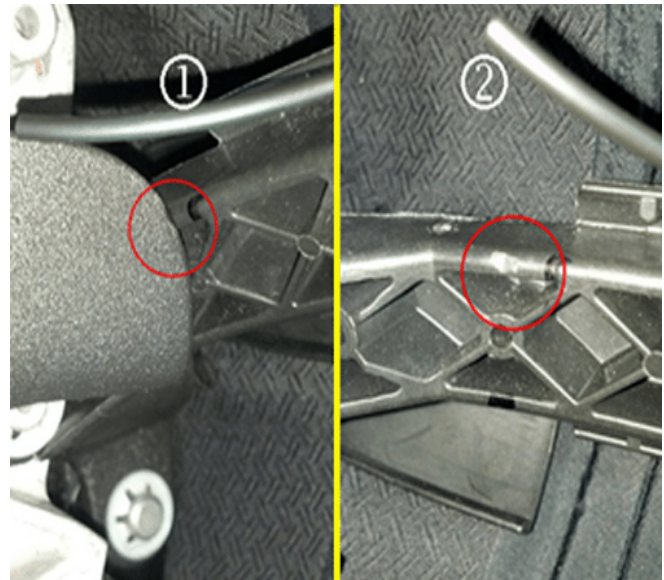

3446274

Note: When the roof rail interference condition occurs, a witness mark may be visible on either/both the roof rail (1) and the #3 bow plastic insert (2).

2. Inspect the roof rails and #3 bows for possible interference of the upper side roof rail to the #3 bow plastic insert.



3446276

3. In cases where interference of the upper roof rail and #3 bow insert is verified, grind or trim material from the #3 bow insert to provide clearance for these parts during top cycling.



3446279

- Once clearance between the roof rail and the #3 bow insert is verified (as shown in the graphic above), replace the headliner following the procedure below.

Condition #2

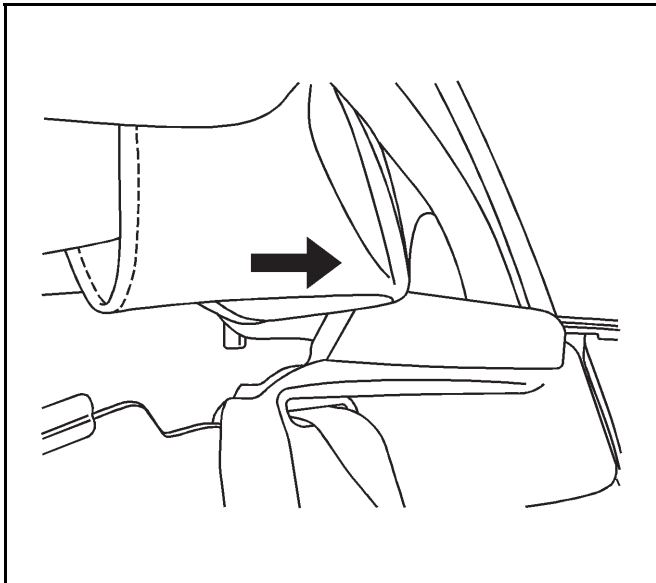

2038817

Some customers may comment on small holes in the rear corners of the headliner.

Cause #2

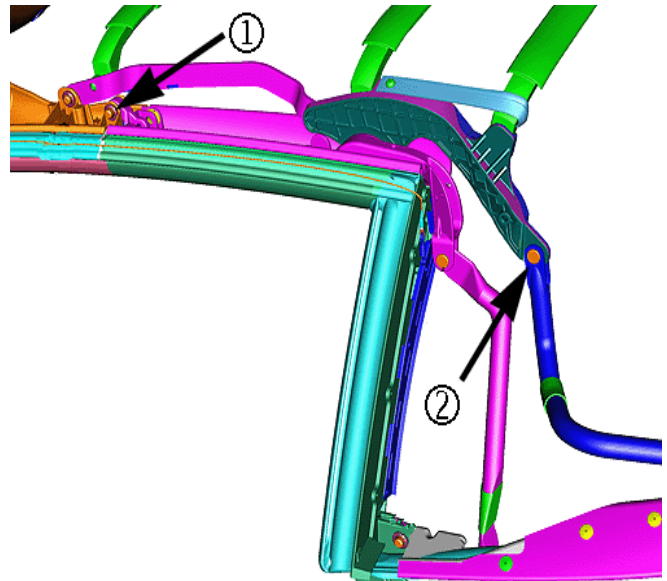

2375929

Note: The forward location on each side (1) uses a longer 24.5 mm (0.965 in) pin and the rear locations (2) use a 20 mm (0.787 in) pin. Also, the pin retainers were changed from a square to a round push nut in mid-model year 2007.

This condition may be caused by any of the four pins and retainers (two per side), which face inward on the folding top. The left side locations are shown in the illustration above.

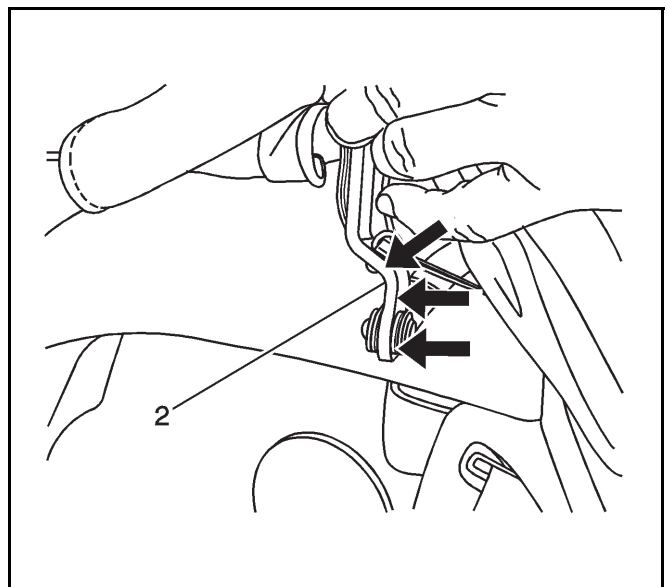

2038818

Or by the sharp edges (2) from the first design folding top link mechanism, shown above, which may be wearing small holes in the rear corners of the headliner when it is stowed.



2374446

Note: The graphic above shows an example of the second design side rail link, which has a burr (at white arrow) on the metal casting. Removing/smoothing out this burr will help protect the headliner from damage during top cycling.

Correction #2

Remove the headliner and replace the four aluminum pins and retainers. There are two pins and two retainers per side. Also check the convertible top linkage for sharp edges. Sand down all sharp edges and paint as necessary. Replace the headliner following the procedure listed below:

Headliner Replacement Procedure

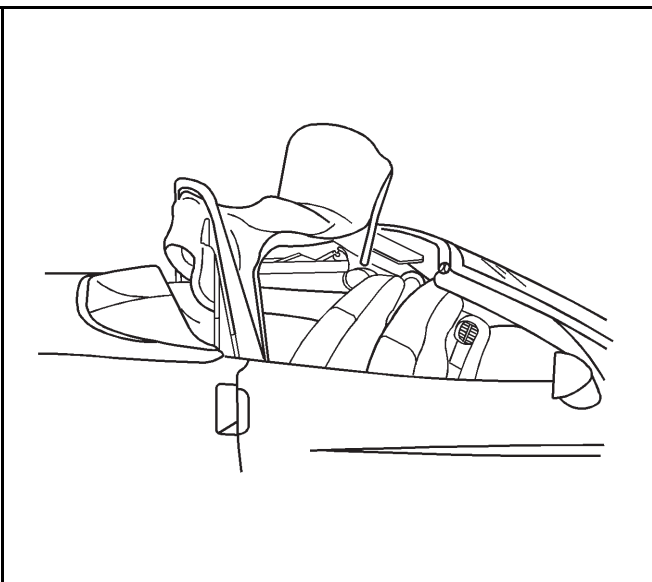

1507225

1. Position the top with the #1 bow and the #5 bow up and secure top with a strap.

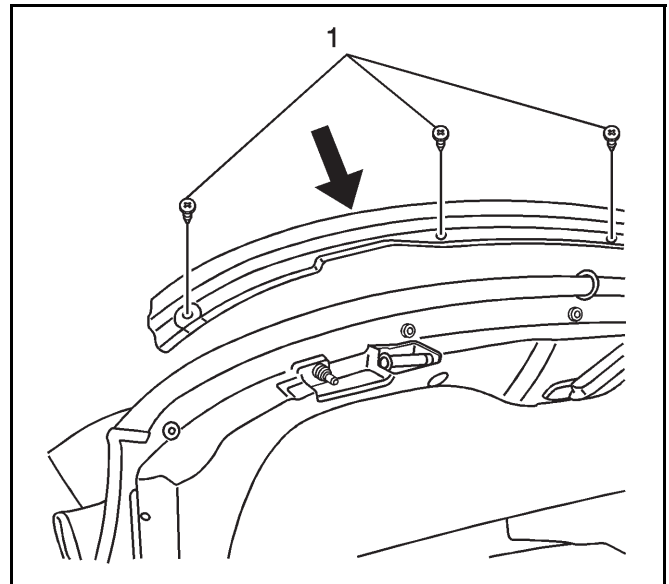

2034642

2. Remove the five folding top compression seal panel screws (1).

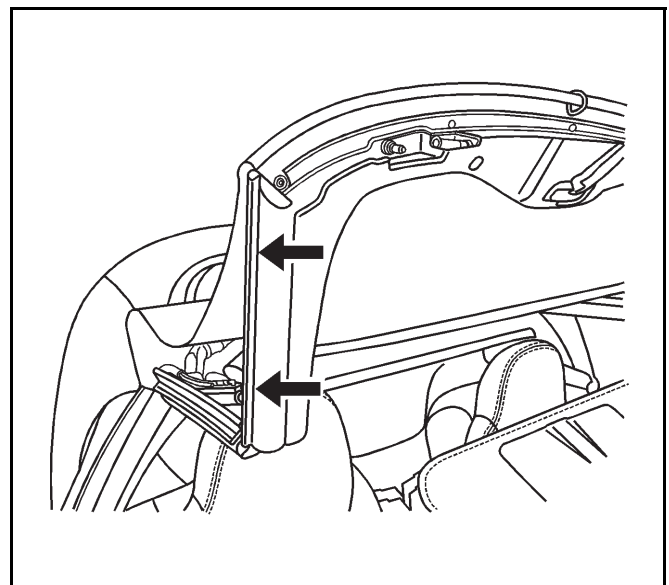

2034640

3. Remove the front weatherstrips and retainers from the right and left sides.

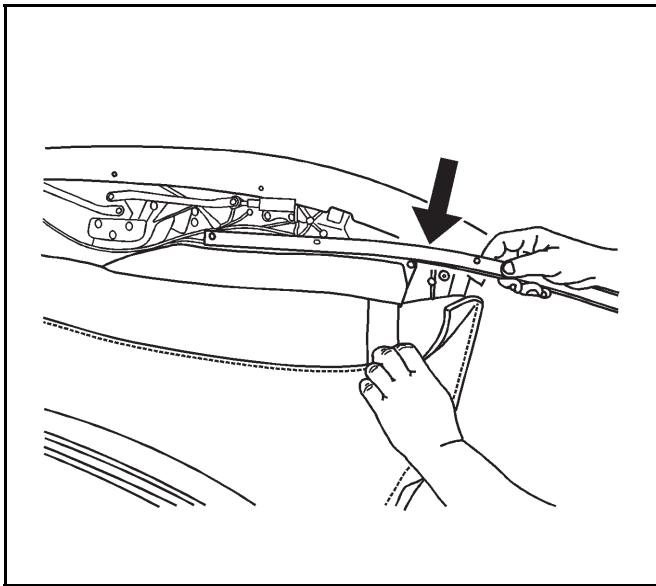

2034650

4. Remove the five folding top cover retaining screws from the #1 header bow and remove the retainer.

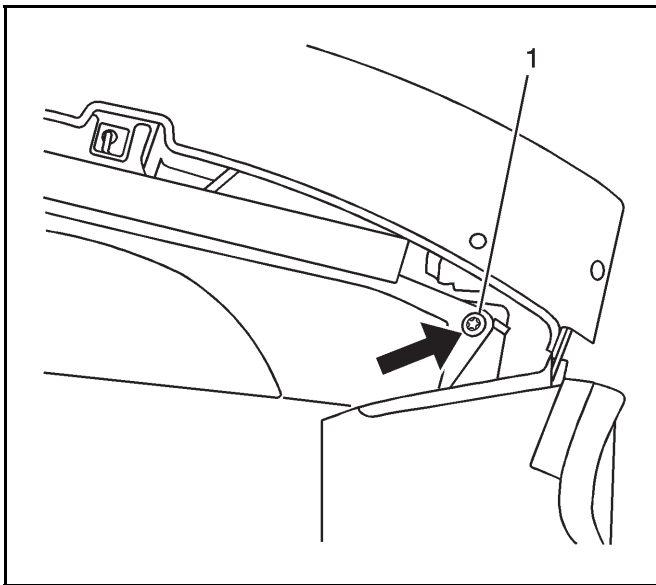

2034641

5. Remove the screws in each front corner of the headliner (1) and pull back the front edge of the top cover from the #1 bow.

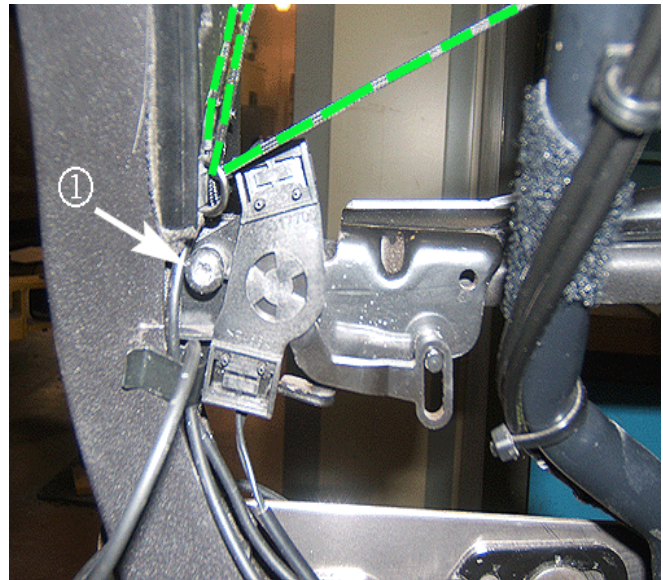

2374448

6. If the vehicle has a power folding top, do the following: To gain access to the folding top switch, remove the interior trim at the top of the B-pillar. Remove the screw (1) from the switch and set aside.

Note: The following two graphics are general references to help with correct position and order of installation of the D-rings on the long headliner string, along with the proper routing of the headliner and anti-glare cover strings.

Figure 1 — Headliner Long String D-Rings

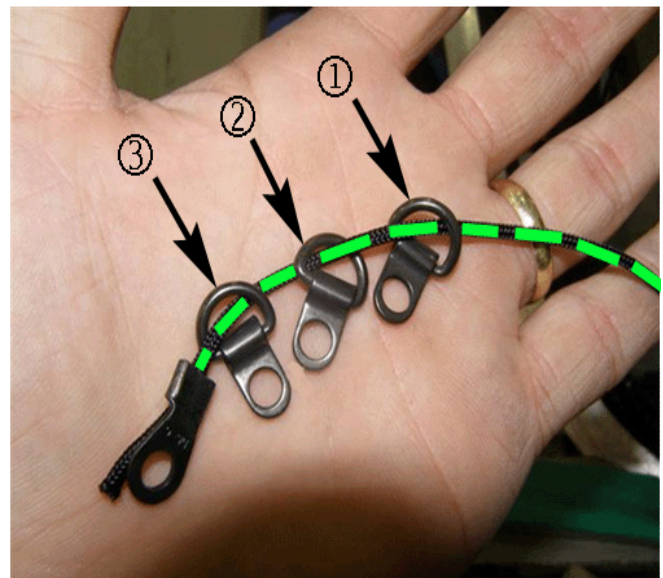

2374450

Tip: The callouts noted above, along with those in the graphic that follows, designate the order AND position of the long headliner string D-ring installation. Note that the installation begins with the D-ring furthest from the end eyelet.

Figure 2 — Headliner and Anti-Glare Cover Strings

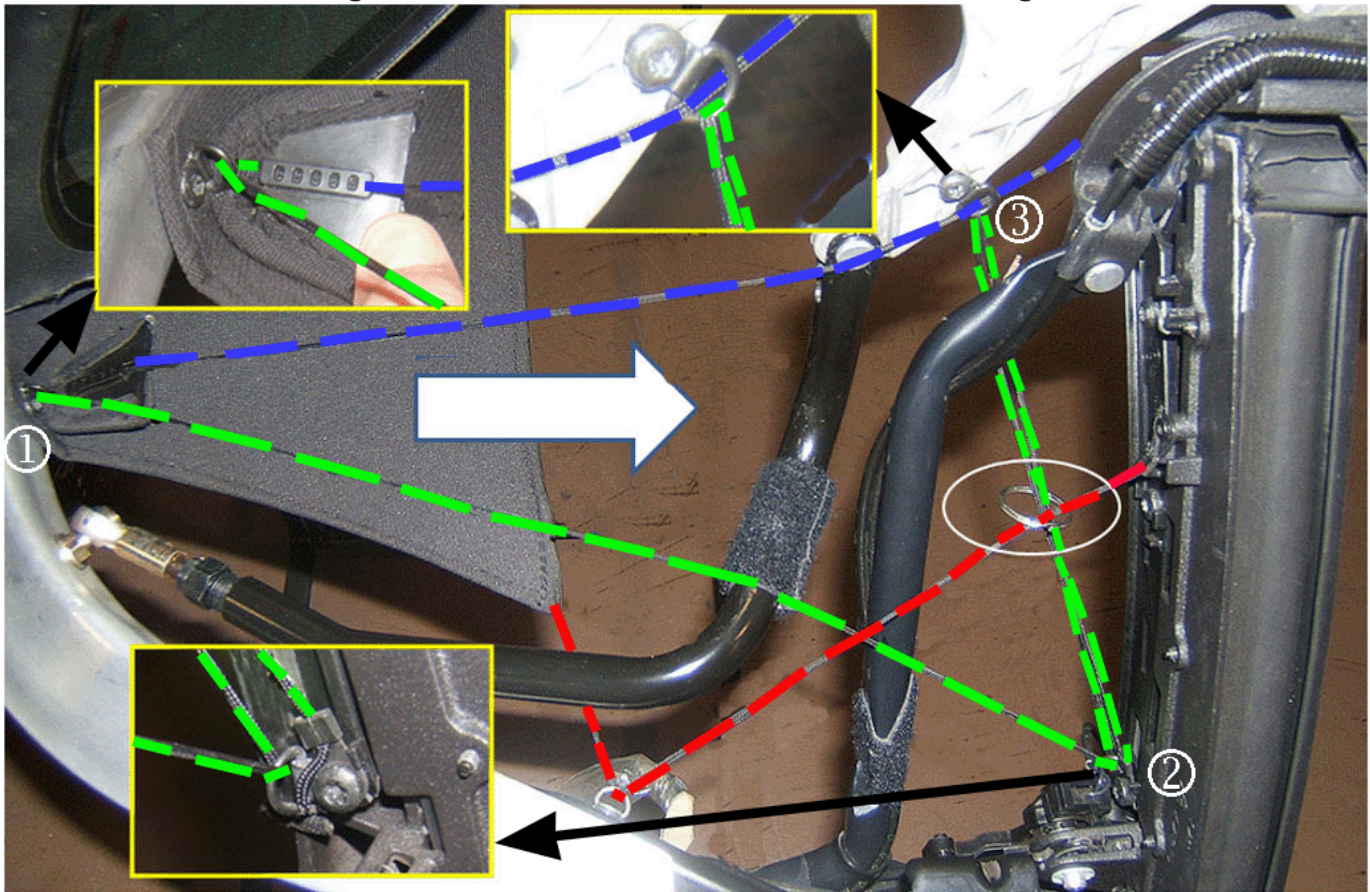

2374451

Important: The above graphic is a view from the right rear of the folding top, with the top in CLOSED position. The headliner and top cover have been partially cut away for illustration purposes. The left side would mirror the right.

Key to cover strings graphic:

- The red color designates the anti-glare cover string which has a single eyelet at the end.
- The green color designates the longer headliner string which contains three D-rings, along with an eyelet at the end.
- The blue color designates the shorter headliner string which has a single eyelet at the end.
- The callouts show the installation position of the D-rings, as well as the order they are installed.

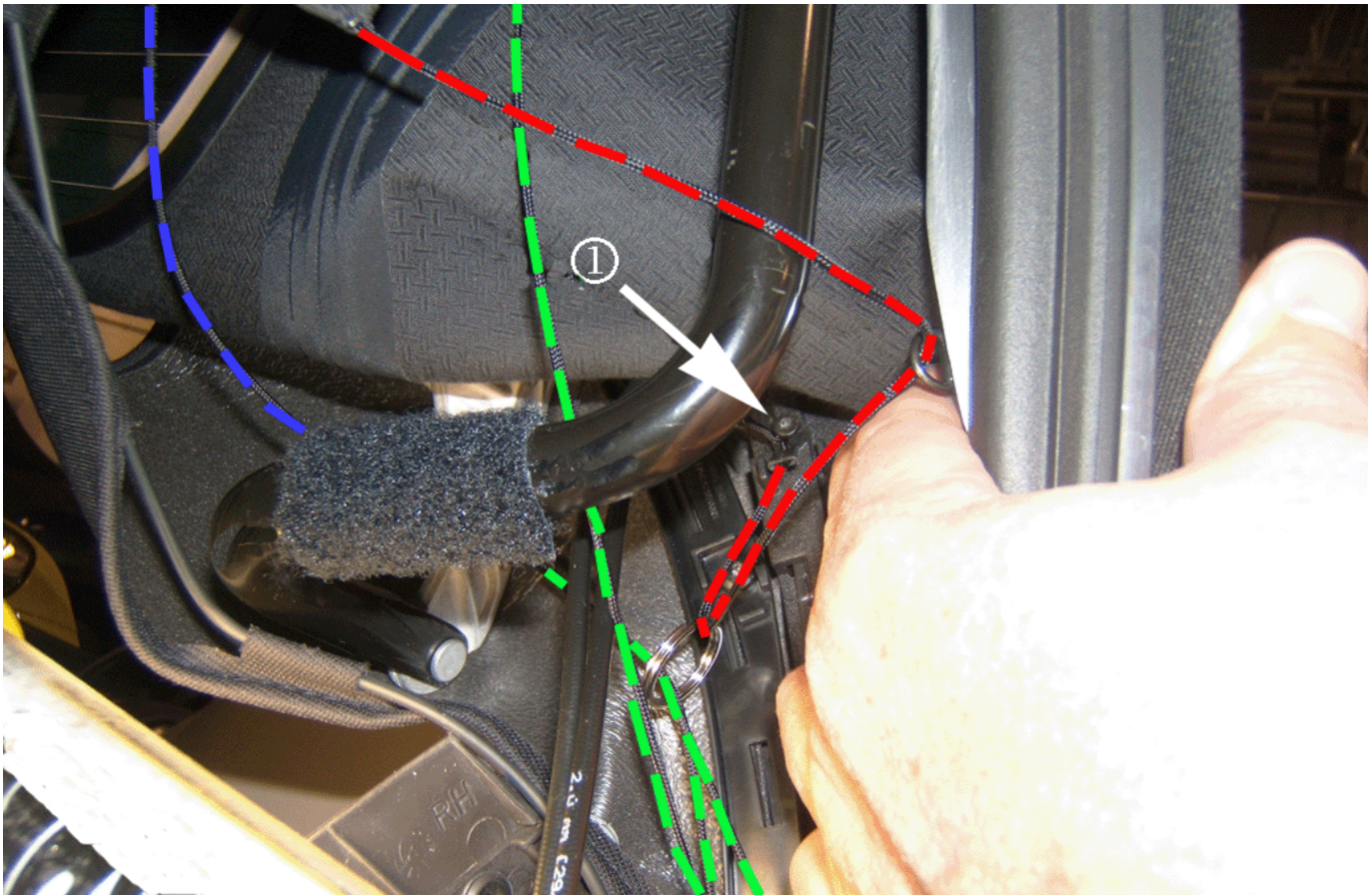

2374452

Note: The anti-glare screen strings are routed through a D-ring that is riveted to the #5 bow, on each side. It is NOT necessary to remove these rivets/D-rings for headliner replacement. After removal of the retaining screws, the end eyelet of each anti-glare string must be fed back through the D-rings. This can be accomplished by slightly opening up the diameter of the D-ring to allow the eyelet to pass through.

7. Remove the screw (1) from the right and left sides of the string holding the anti-glare screen (shown in red above) to the rear side rail. Fold the anti-glare screen over the top of the number 5 bow.

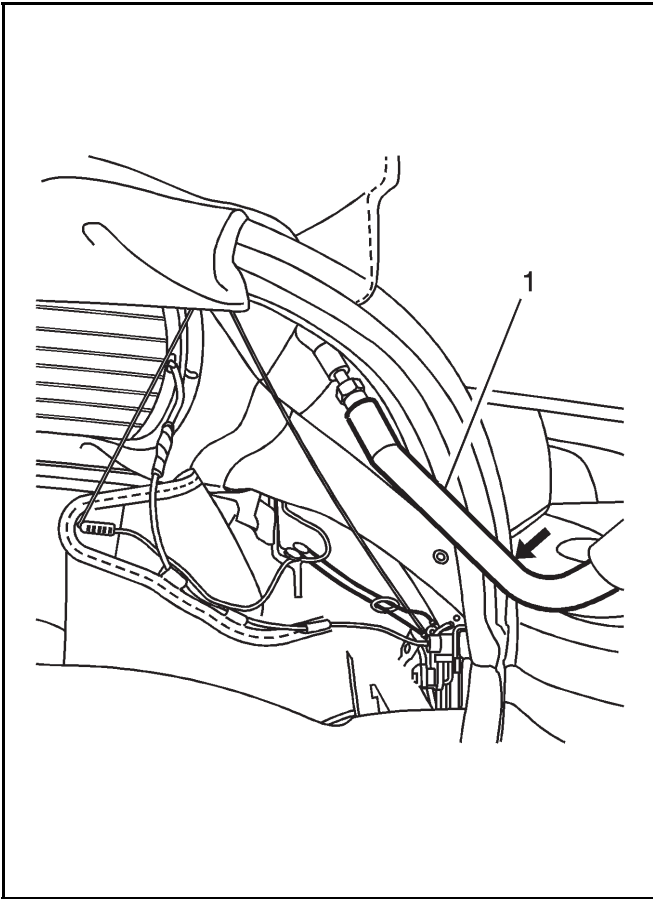

2034654

8. Disconnect the folding top #5 bow link arm pins/spring clips and set the arms (1) aside.

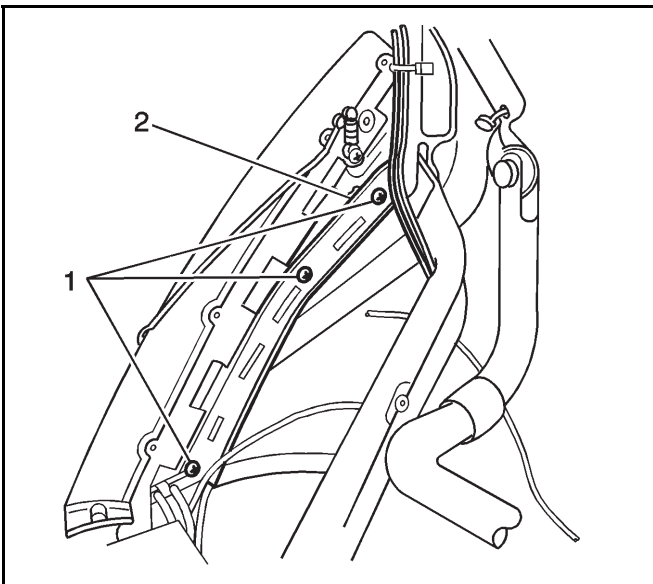

2043255

Note: Note that the retainer bracket's bottom screw also retains the long headliner string's second D-ring and end eyelet, on each side.

9. Remove the three headliner retaining screws (1) and remove the retainer bracket (2) from the right and left sides.



2374453

10. Start removing the long headliner string (shown in green above) by removing the screw (1) from the first D-ring on the underside of the #5 bow, on the right and left side.

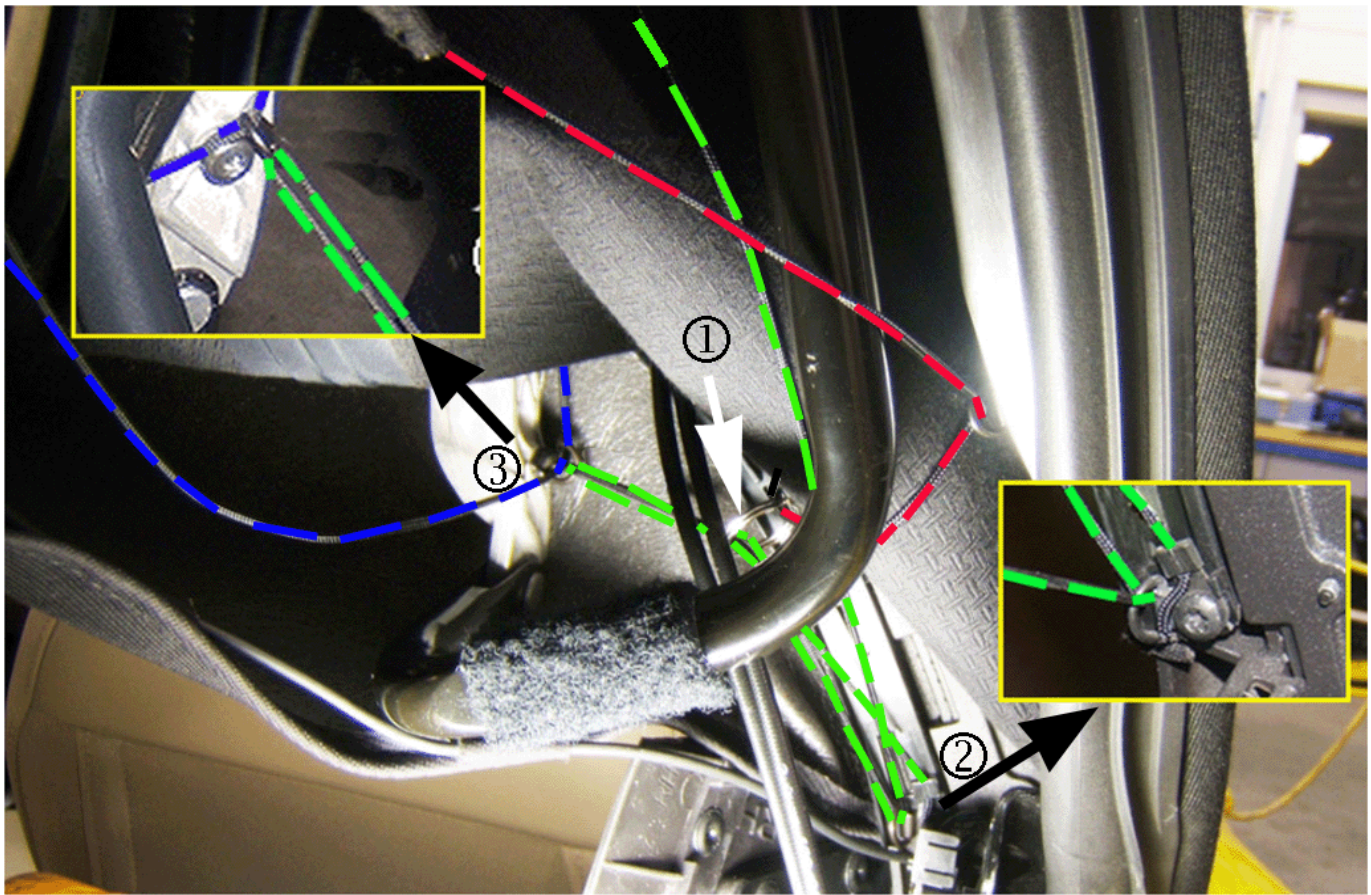

11. Next, remove the screw holding the second D-ring and the string's end eyelet (position 2 above) to the rear side rail, from the right and left side.

Important: After removal of the third D-ring, slide the metal key ring (1) off the string and retain for installation of the new headliner.

12. Remove the third D-ring (position 3 above) from the right and left side, following the appropriate steps below:

Figure 3 – First Design Side Rail Link

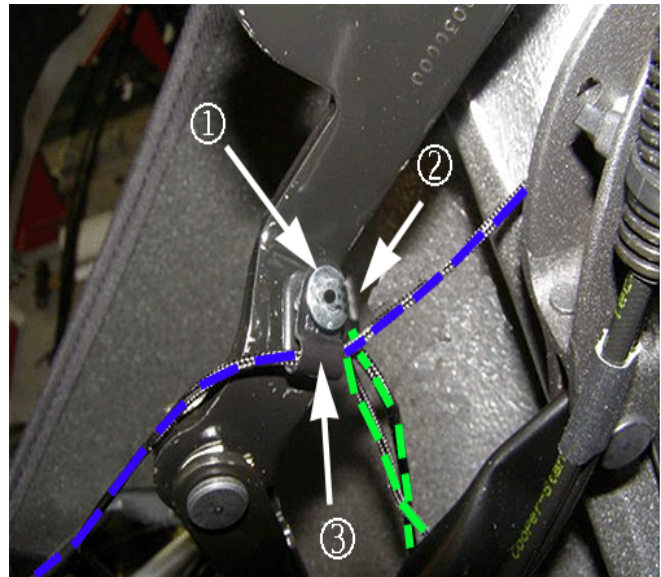

2374454

2374456

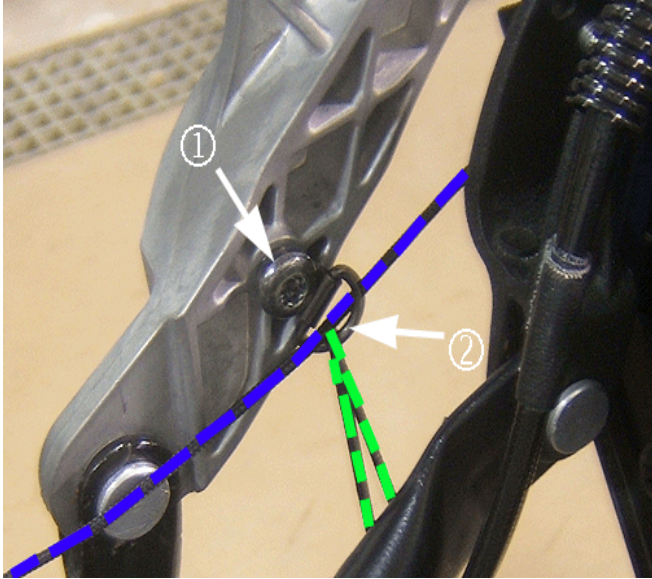
Figure 4 – Second Design Side Rail Link

2374457

Note: Vehicles built prior to March 15, 2008 have the first design side rail links shown in Figure 3. This design had a rivet (1) securing a D-ring (2) and a metal P-clip (3). As shown in Figure 4, vehicles built after that date are a second design that have a larger metal casting side rail link with a screw (1) securing the D-ring (2), and no P-clip. For first design vehicles, complete steps 12.1–12.3; for second design vehicles, begin with step 12.4.

- 12.1. Protect the rear compartment from drill shavings.
- 12.2. Drill out the rivet, Figure 3 (1), holding the third D-ring and metal P-clip on the right and left side. Retain the P-clips.
- 12.3. Proceed to step #13.
- 12.4. Remove the screw, Figure 4 (1) from the third D-ring (2) on the right and left side.

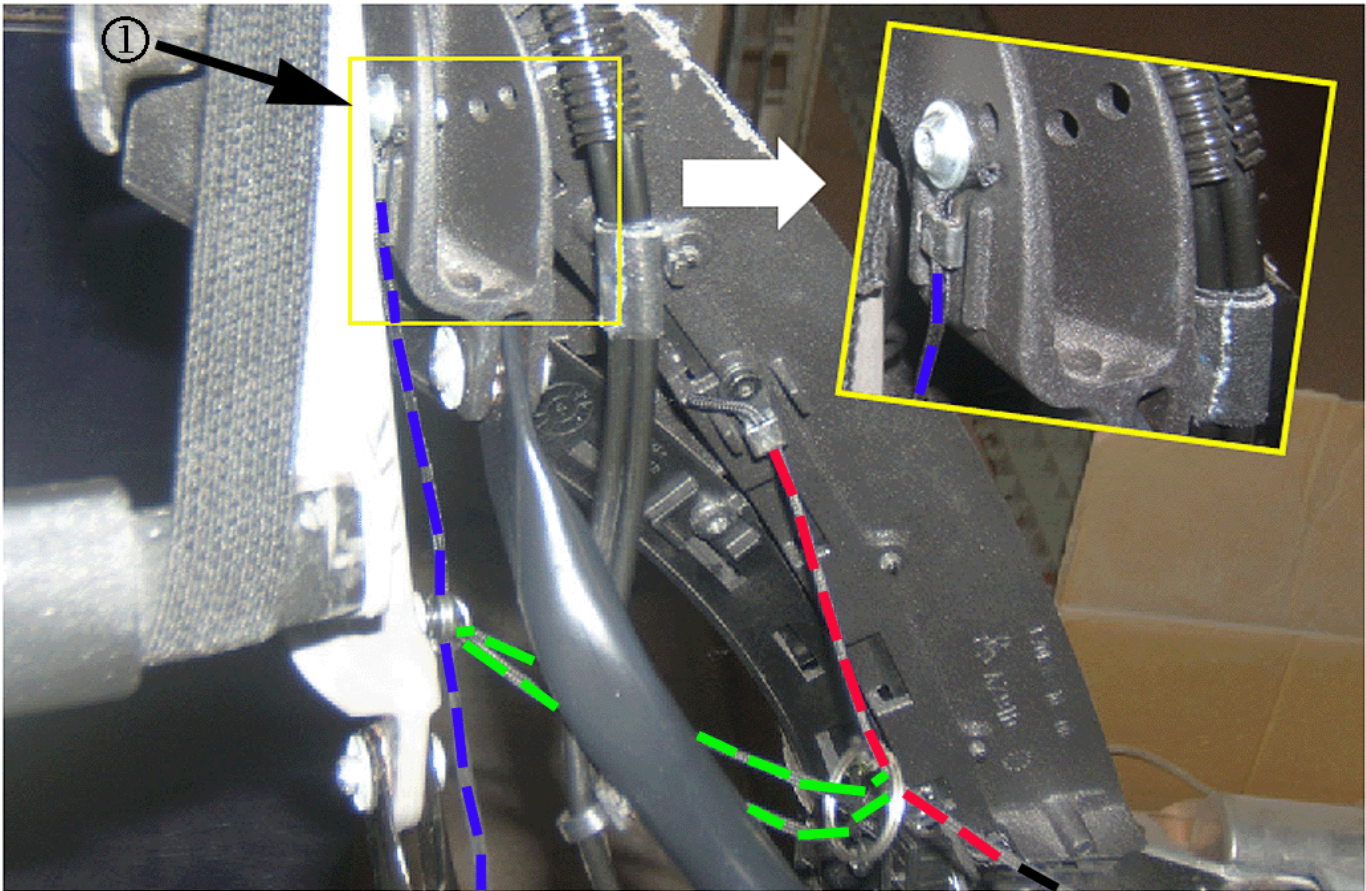

2374458

Note: Temporarily lowering the #1 bow will allow for easier access to the short headliner string attachment screw locations.

13. Remove the screw (1) holding the end eyelet of the short headliner string to the inboard side of the side rail links (shown in blue above), from the right and left side.
14. Disconnect the rear defroster wiring harness.
15. Remove the headliner by sliding it through the #2, #3 and #4 roof bows. Slide the material simultaneously within the bows in order to avoid binding.
16. To install the headliner slide the material into the #2, #3, and #4 bows. Slide the material simultaneously within the bows to avoid binding.

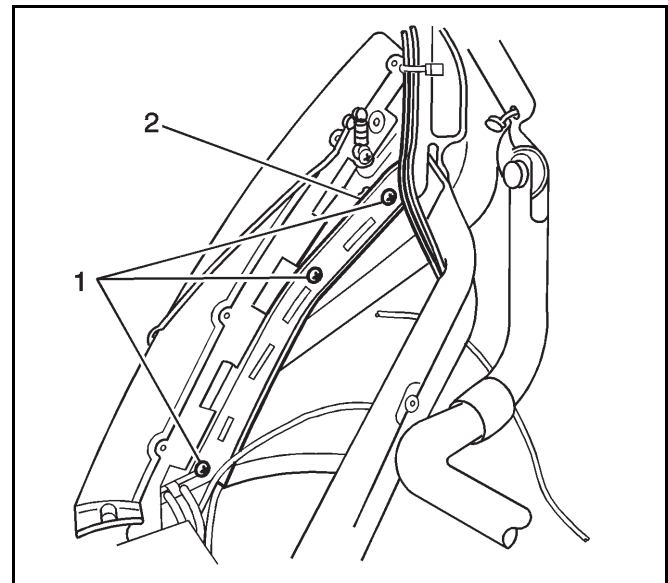

2043255

17. Install the headliner material into the headliner retainer brackets (2).
18. Position the bracket (2) and the headliner to the rear side rail.

Note: Install only the top two retainer bracket screws to each side, at this time. The bottom screws, which also retain the long headliner string, will be attached later during step 21.

19. Install the screws (1) to secure the bracket and headliner to the rear side rail.

Tighten

Tighten to 2 N•m (18 lb in).



2374453

Important: Ensure that the D-ring is pointed toward the interior of the vehicle, as shown above.

20. Starting with the long headliner string (shown in green above), take the D-ring (1) furthest from the end eyelet and attach it to the underside of the #5 bow, on the right and left side.

Tighten

Tighten to 2 N•m (18 lb in).

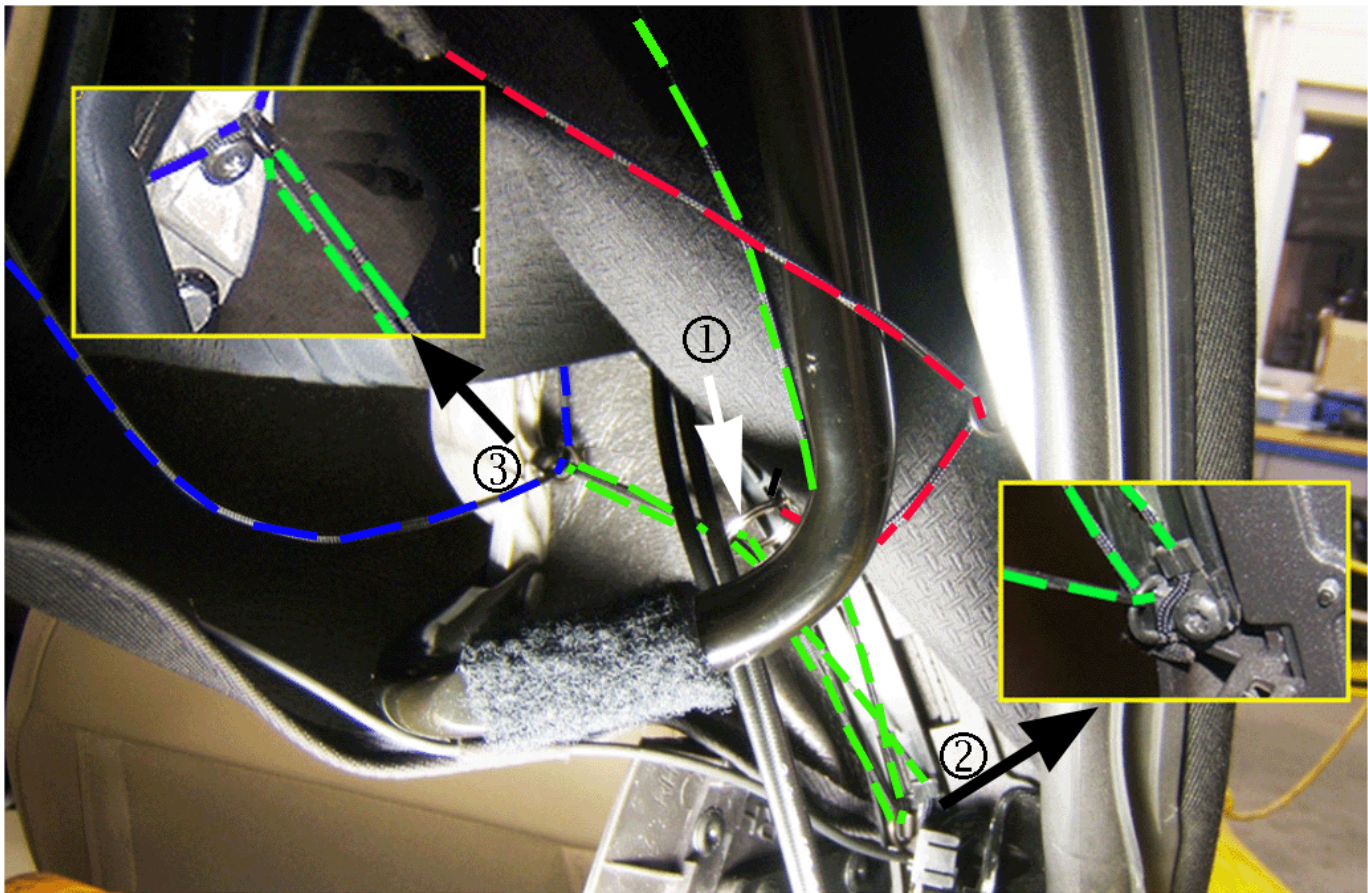

2374454

Important: Ensure that the orientation of the D-ring and eyelet are as shown above and that the string is routed on the outboard side of the rear counterbalance link, as shown earlier in Figure 2.

21. Attach the second D-ring and the end eyelet of the string to the bottom screw location of the headliner retainer bracket (position 2 shown above), on the right and left side.

Tighten

Tighten to 2 N•m (18 lb in).

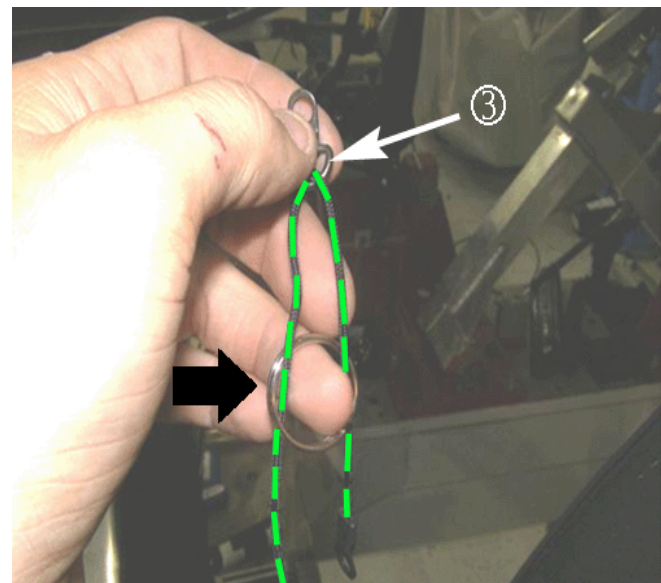

2368690

Note: For illustration purposes, the third D-ring and metal key ring are shown outside the vehicle. When actually doing this step, the end eyelet (hanging down in the above graphic) and the second D-ring will already be attached.

Important: Whether first or second design, when attaching the third D-ring, ensure that the string is routed underneath the rear counterbalance link, as shown earlier in Figure 2.

22. On the right and left side, grab the third D-ring (3), slide the metal ring (black arrow) over the string, and attach the D-ring to the side rail link using the appropriate procedure below. For first design vehicles, complete step 23.1; for second design vehicles, begin with step 23.2.

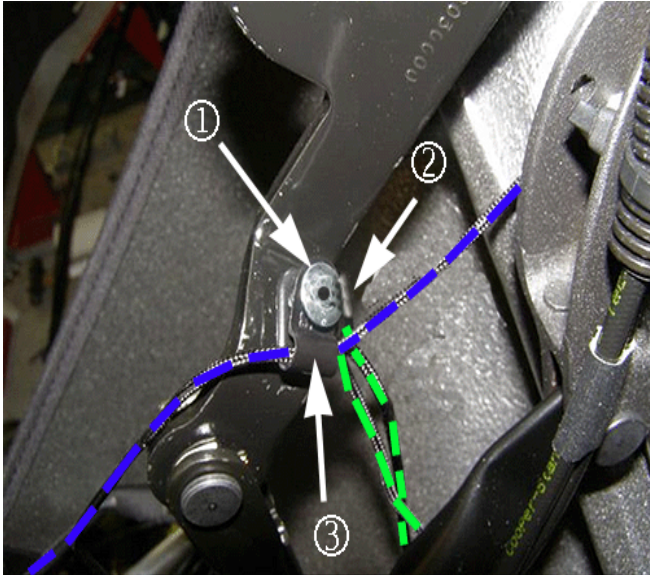

2374456

Note: If the P-clip is not on the new headliner string, install the ones retained from the original headliner.

Important: Prior to securing the rivet, ensure that the short headliner string (shown in blue above) is routed through the P-clip and that the D-ring and P-clip are in the proper orientation. The P-clip should point to the outside of the vehicle and the D-ring should point forward.

- 22.1. Attach the third D-ring (2) and the P-clip (3) to the side rail link using a rivet (1), on the right and left side.

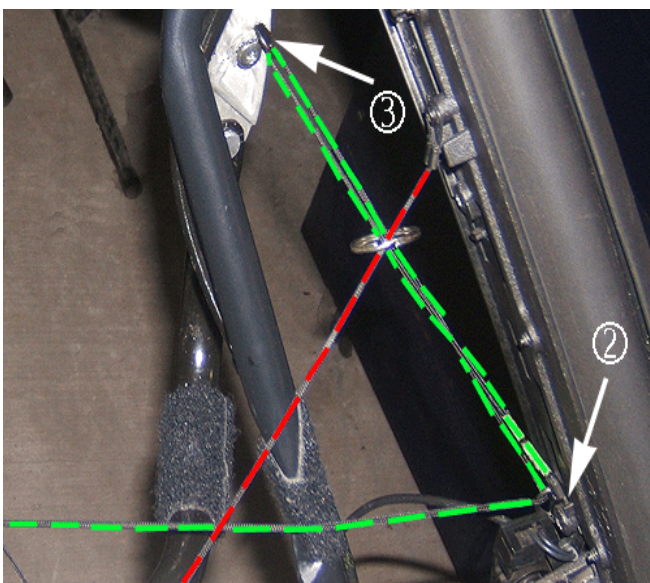

2374469

Note: Though not attached yet, the anti-glare cover string (in red) is shown in the above graphic for illustration purposes. This helps show the proper orientation of the D-ring and the metal key ring, when the top is in closed position.

Important: The short headliner string (shown in blue in the graphic below) must be routed through the third D-ring (3) of the longer string. This is easier to do PRIOR to attaching the third D-ring and can be accomplished by slightly opening up the diameter of the D-ring to allow the short string's end eyelet to pass through.

- 22.2. Attach the screw that retains the third D-ring (3) to the side rail link, on the right and left side. Ensure that the D-ring is pointed to the front of the vehicle, as shown above.

Tighten

Tighten to 2 N•m (18 lb in).



2374460

Important: Prior to attaching the end eyelets, ensure that the short headliner string (shown in blue above) is routed through the P-clip (design one) or fed through the third D-ring (3) of the long headliner string (design two, shown above).

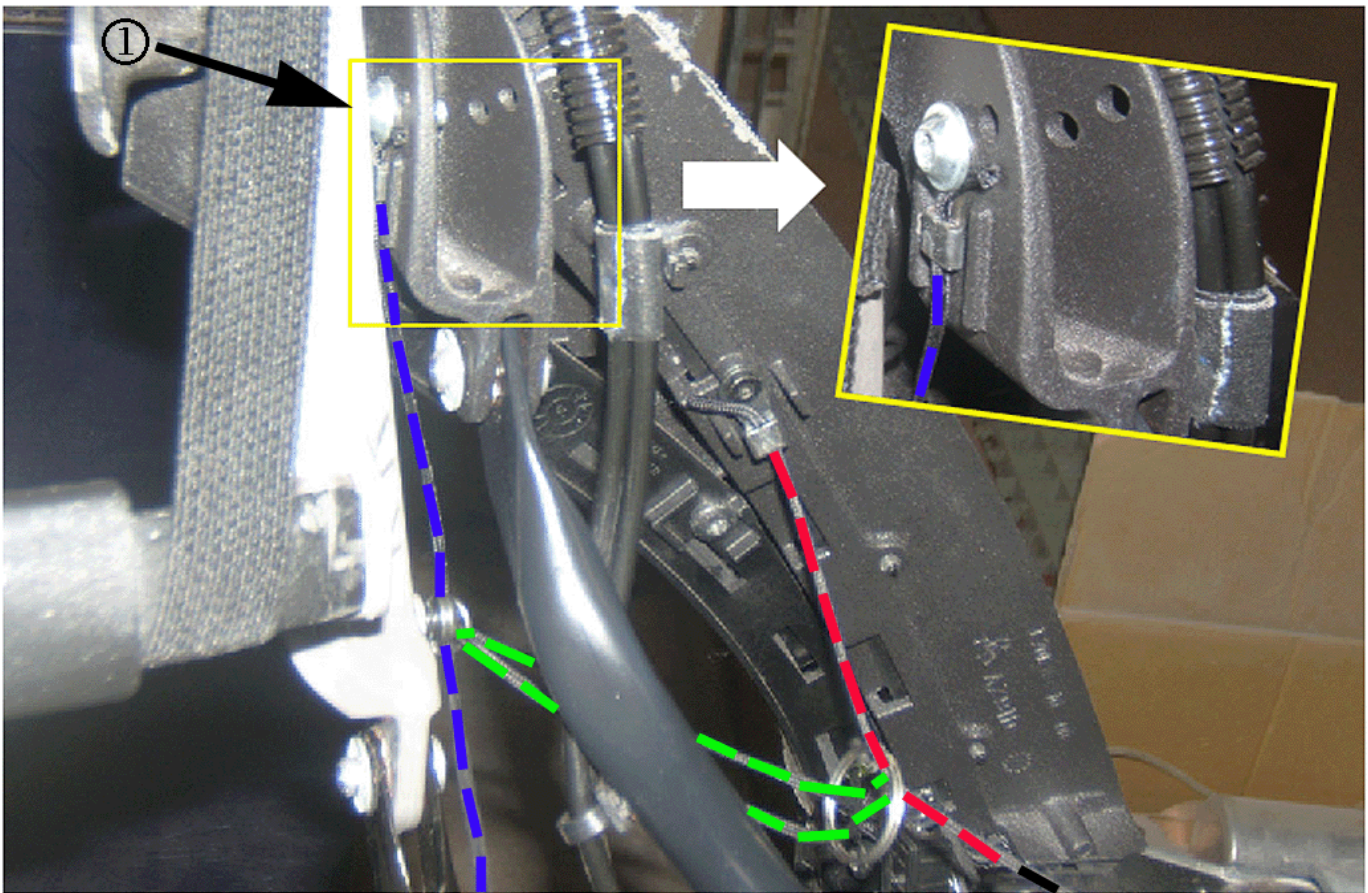

2374458

Note: Temporarily lowering the #1 bow will allow for easier access to the short headliner string attachment screw locations.

23. Install the screw (1) that attaches the end eyelet of the short headliner string (shown in blue above) to the inboard side of side rail link, on the right and left side.

Tighten

Tighten to 2 N•m (18 lb in).

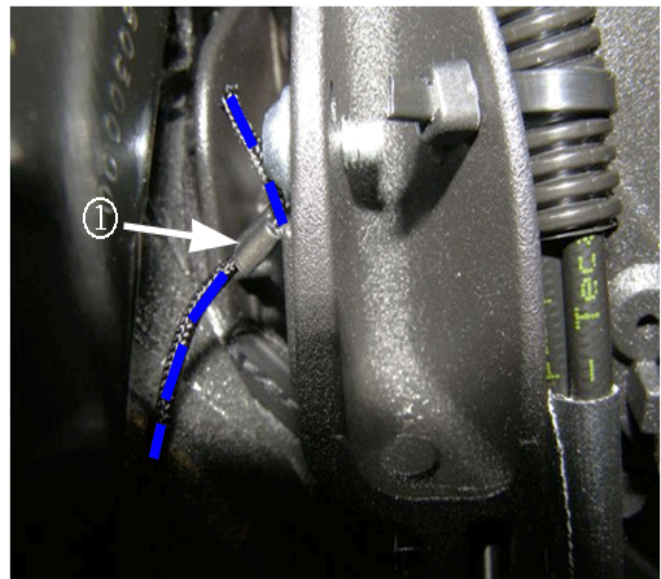

2374461

24. After the screws are installed, grab and pull the short string inboard to raise the eyelet (1) off of the side rail link, on the right and left side.
25. Reconnect the rear defroster wiring harness.

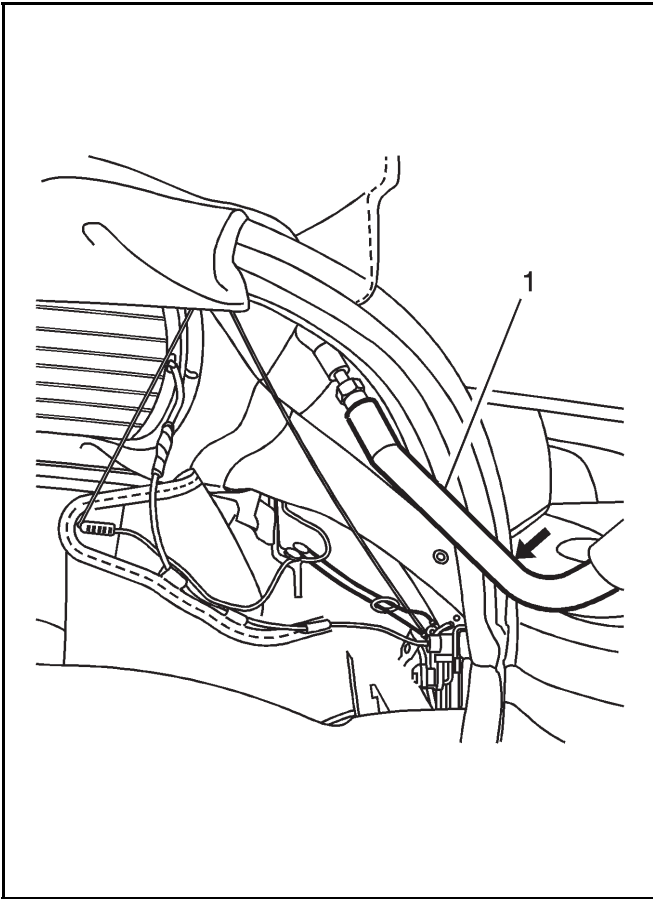

Important: Prior to installing the #5 bow link arms, lower the #1 and #5 bow to normal closed position and inspect the headliner for proper string routing and tension.

Note: When installing the #5 bow link arms, ensure that the long headliner string is routed above the arms as shown earlier in Figure 2.

26. Install the folding top #5 bow link arms (1) and pins/spring clips.

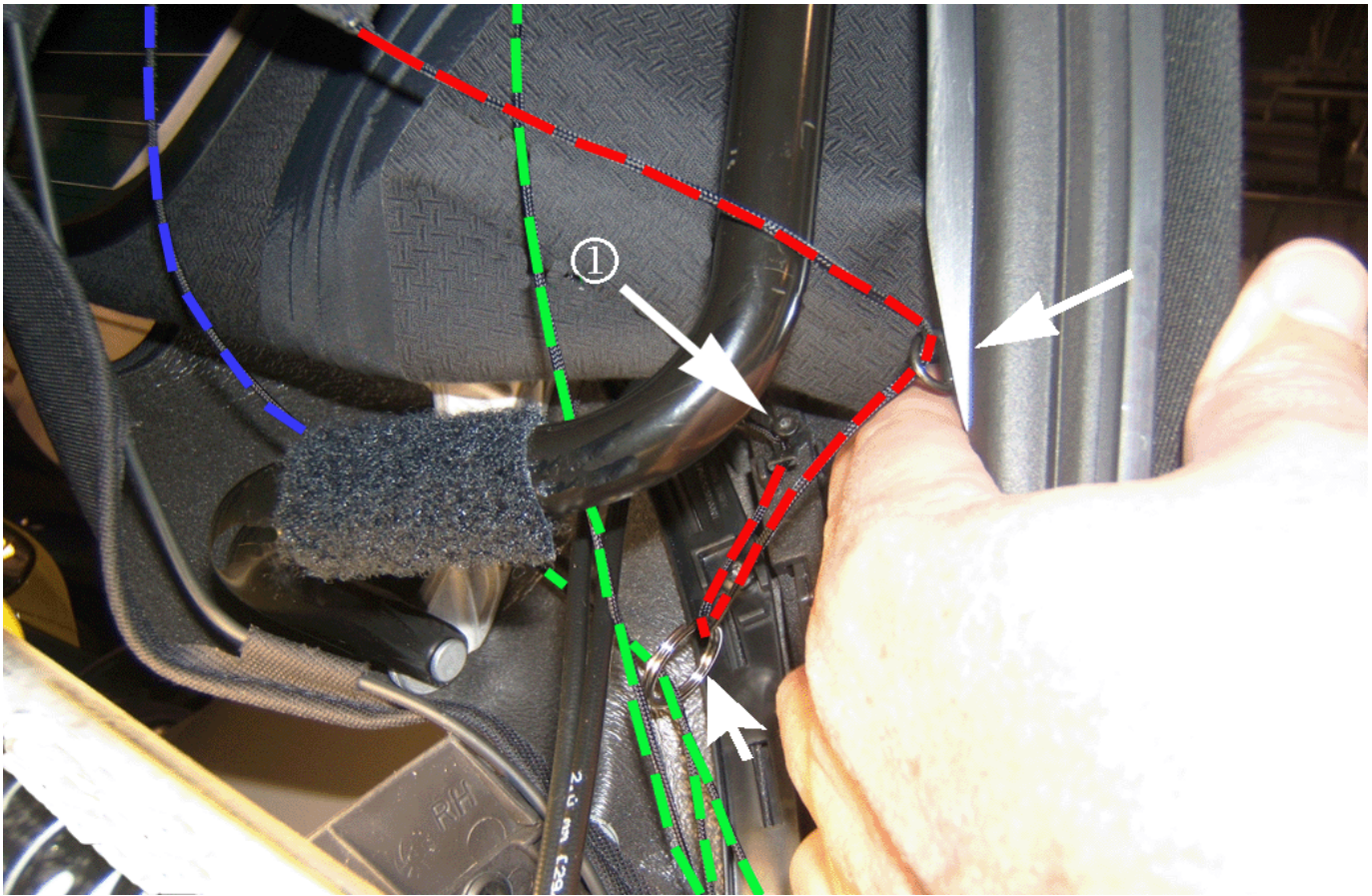

2374374

27. Route the anti-glare cover string (shown in red above) under the #5 bow link arms, through the eyelet on the #5 bow (right arrow), through the metal key ring (lower arrow) and then attach the screw (1) holding the end eyelet to the rear side rail, on the right and left side.

Tighten

Tighten to 2 N•m (18 lb in).

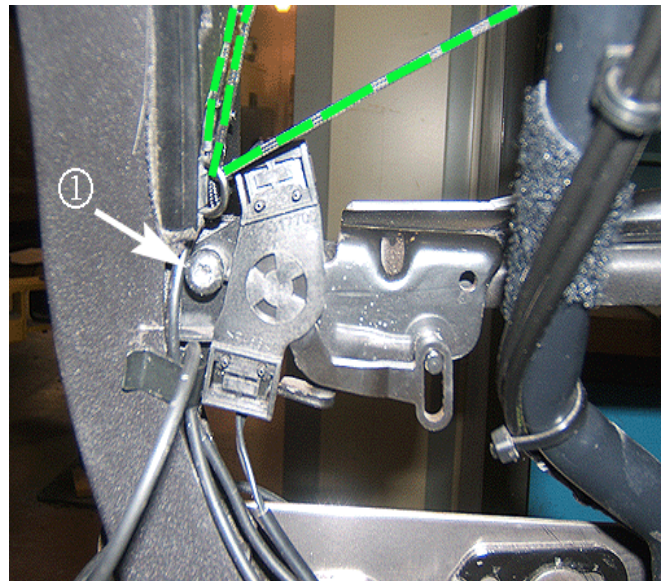

2374448

28. Install the folding top position switch and screw (1) if equipped and the interior trim to the top of the B-pillar.

Tighten

Tighten to 8 N•m (70 lb in).

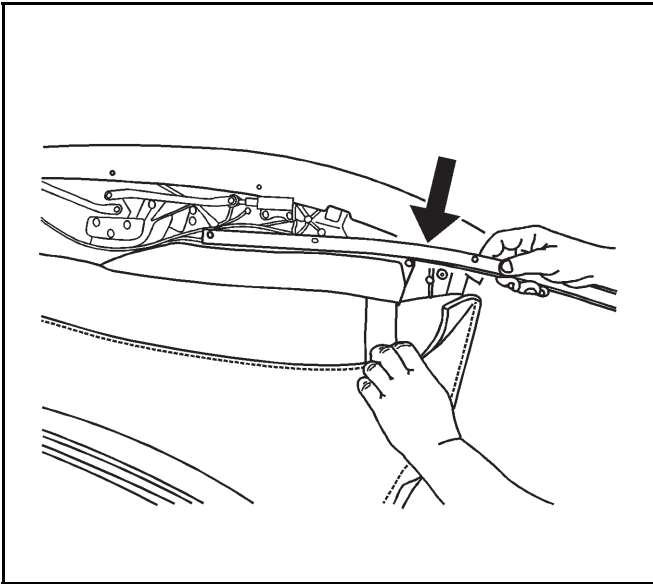

2034650

29. Install the headliner retainer and five screws to the #1 bow.

Tighten

Tighten to 2 N•m (18 lb in).

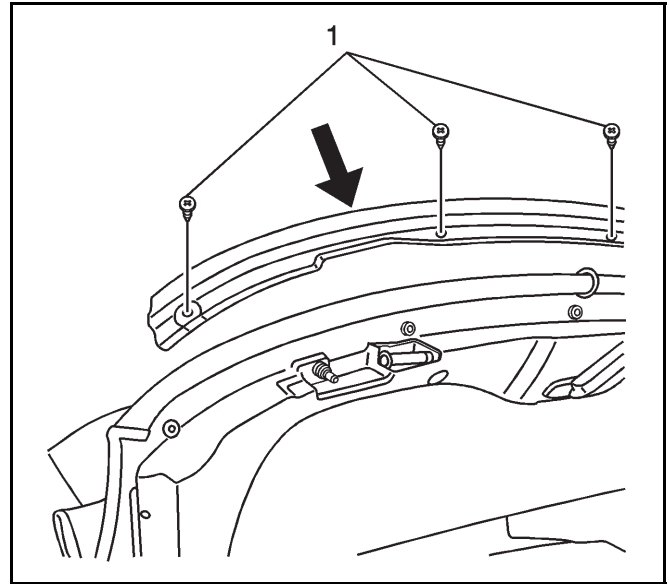

2034642

31. Fold the top cover over the #1 bow and install the top cover compression seal panel retainer and screws (1).

Tighten

Tighten to 6 N•m (53 lb in).

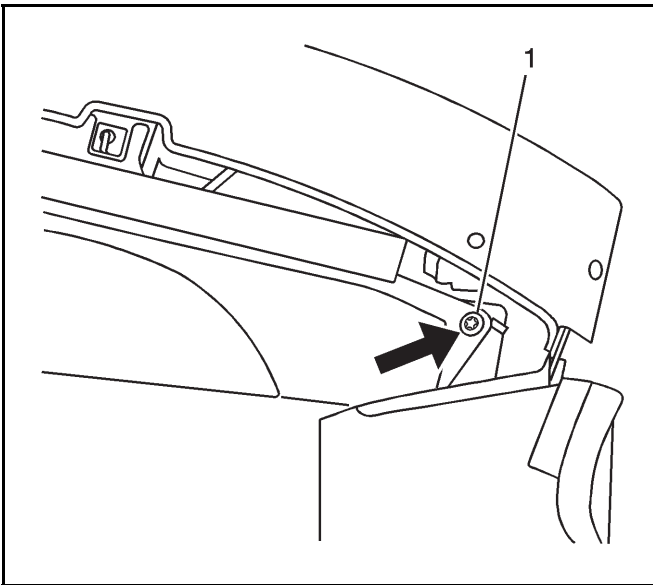

2034641

30. Install the screw (1) in each corner of the headliner.

Tighten

Tighten to 2 N•m (18 lb in).

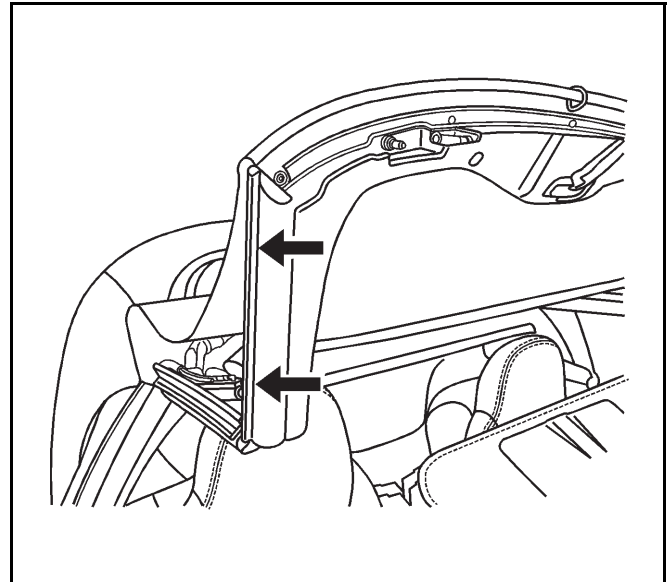

2034640

32. Install the front retainer and weatherstrip on both sides.

Tighten

Tighten to 3 N•m (29 lb in).

33. Manually place top in closed position. Observe headliner as top header approaches header. If headliner strings are binding or stretching, stop. Check strings for proper routing.

Parts Information

Part Number	Description
19181260	Push Nut (4 per vehicle)
19181261	Aluminum Pin (2 per vehicle)
19181262	Aluminum Pin (2 per vehicle)
19207984	Panel Kit, F/Top Hdng Tr

Warranty Information

For vehicles repaired under warranty, use:

Labor Operation	Description	Labor Time
6080018*	Headliner Assembly, Folding Top – Replace, File Sharp Edge & Touch Up	1.6 hrs
*This is a unique labor operation for bulletin use only. It will not be published in the Labor Time Guide.		

