

SUBJECT:**ELANTRA SEDAN AND COUPE
BRAKE PAD REPLACEMENT – 2013 MY (SERVICE CAMPAIGN TM3)****Applicable Vehicles:**

ELANTRA SEDAN (MD/UD), ELANTRA COUPE (JK)
 Applicable vehicle production date range:
 Korean Built Sedan (MD) : From March 8, 2012 to Aug. 31, 2012
 USA Built Sedan (UD) : From March 8, 2012 to Sep. 4, 2012
 Coupe (JK) : From March 17, 2012 to Sep. 4, 2012

Part Information:

PART NAME	PREVIOUS	NEW	REMARK
Front Pad Kit			LH (Inner)
			RH (Inner)
			LH/RH (Outer)
Service Campaign Front Pad Kit Part Number	581013X200QQH		

Warranty Information:

MODEL	OP CODE	OPERATION	OP TIME
Korean Built Sedan (MD)	20C106R0	Front brake pad replacement (both sides)	0.5 M/H
USA Built Sedan (UD)	20C106R1		
Coupe (JK)	20C106R2		

NOTE: Submit Claim on Campaign Claim Entry Screen

Service Procedure:

1.

*** NOTE**

Verify that the vehicle is in the affected production date range.

Lift the vehicle.

2. Remove the right front wheel lug nuts (A).

Tightening Torque :

90~110Nm(9.0~11.0kgf.m, 65~80lb-ft)

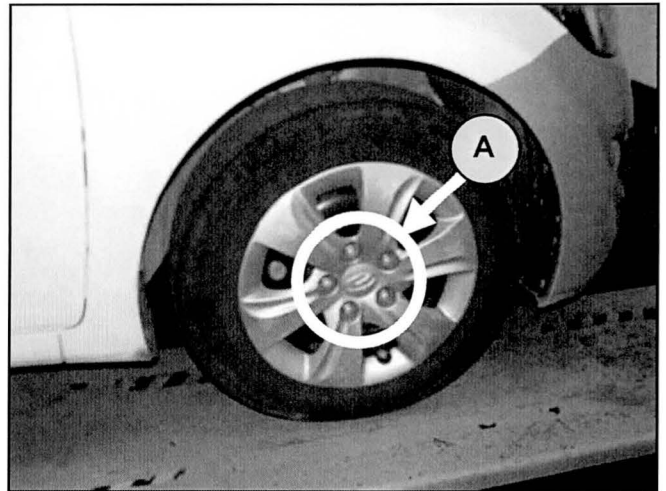

3. Remove the front wheel assembly (B).

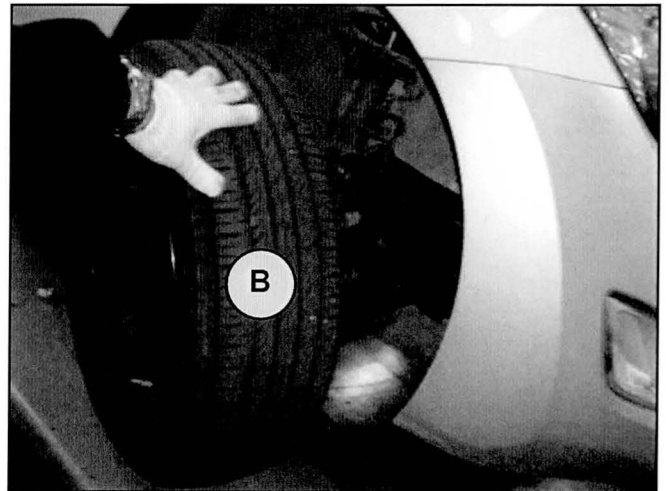

SUBJECT:

**ELANTRA SEDAN AND COUPE
BRAKE PAD REPLACEMENT – 2013 MY (SERVICE CAMPAIGN TM3)**

4. Remove the caliper guide rod bolt (C).

Tightening Torque :

21.57 ~ 31.38Nm (2.2~3.2kgf.m, 15.9 ~ 23.1 lb-ft)

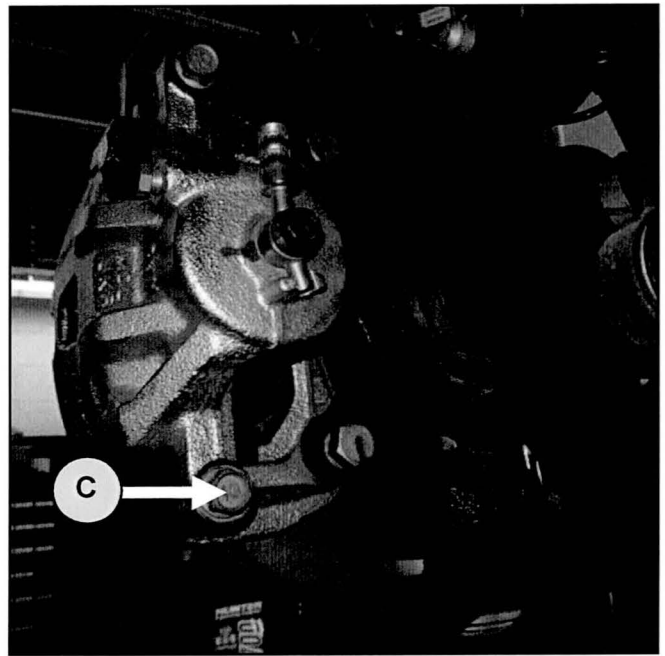

5. Raise the caliper (D) as shown.

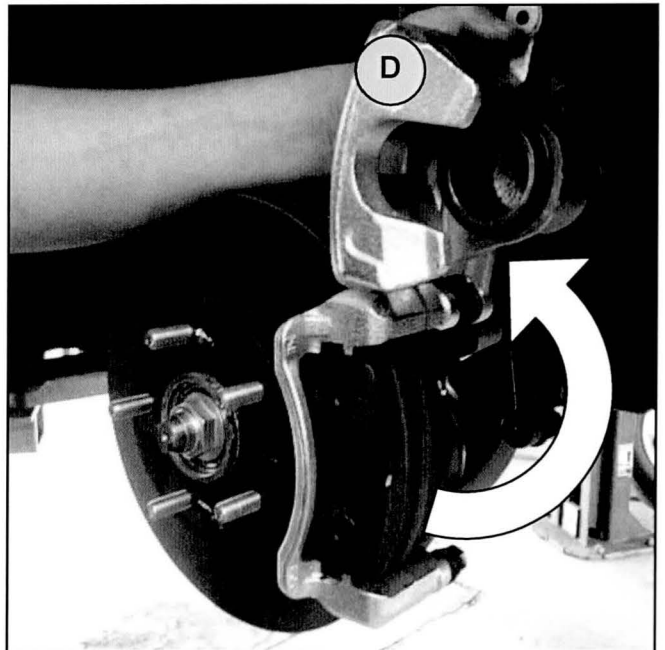

6. Remove the brake inner pad (E).

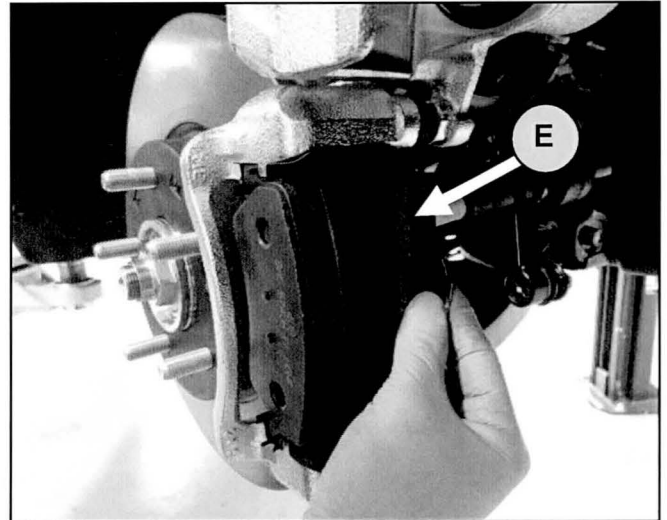

7. Remove the brake outer pad (F).

*** NOTE**
Do not lose retainers (G), they will be reused.

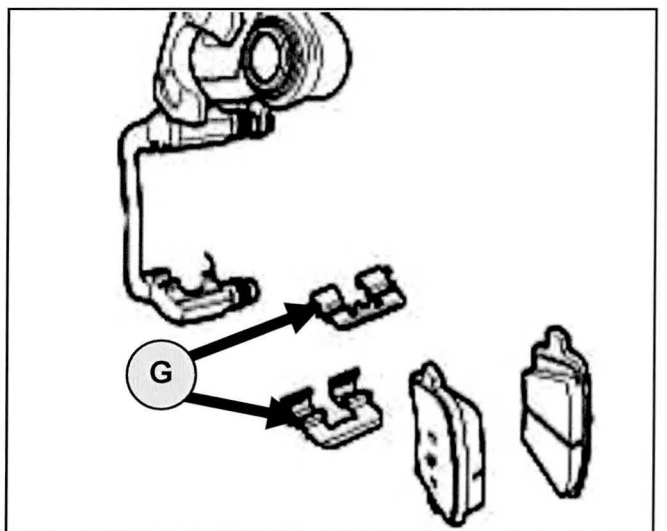
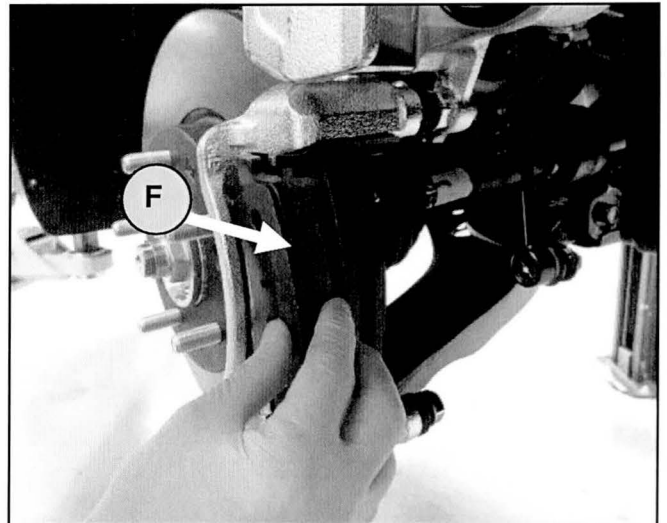

SUBJECT:

**ELANTRA SEDAN AND COUPE
BRAKE PAD REPLACEMENT – 2013 MY (SERVICE CAMPAIGN TM3)**

8. Before installing brake outer pad, peel off the plastic protective film (H) covering the adhesive surface on the backing plate.

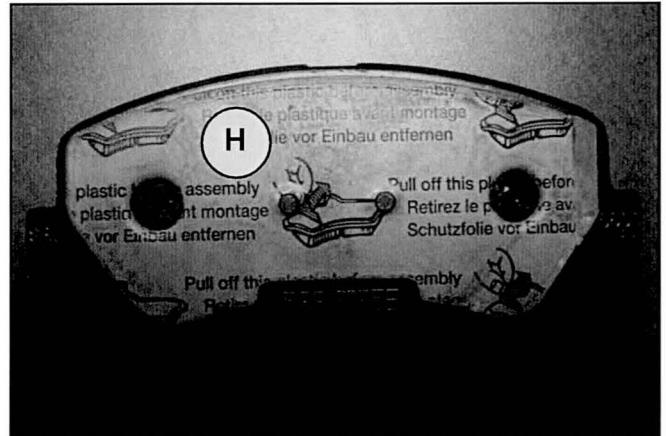

9. Install new brake inner and outer pad.

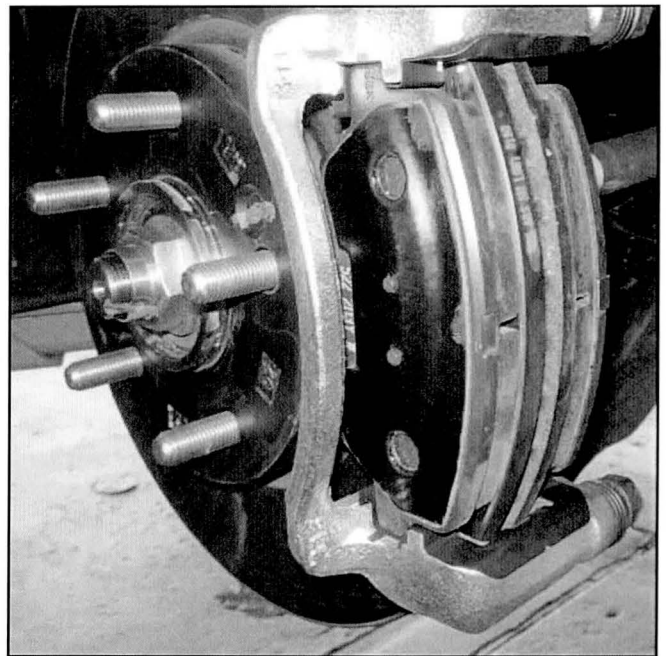

SUBJECT:**ELANTRA SEDAN AND COUPE
BRAKE PAD REPLACEMENT – 2013 MY (SERVICE CAMPAIGN TM3)**

10. The caliper piston (I) may need to be pushed in to provide clearance between the caliper and pads during reinstallation.

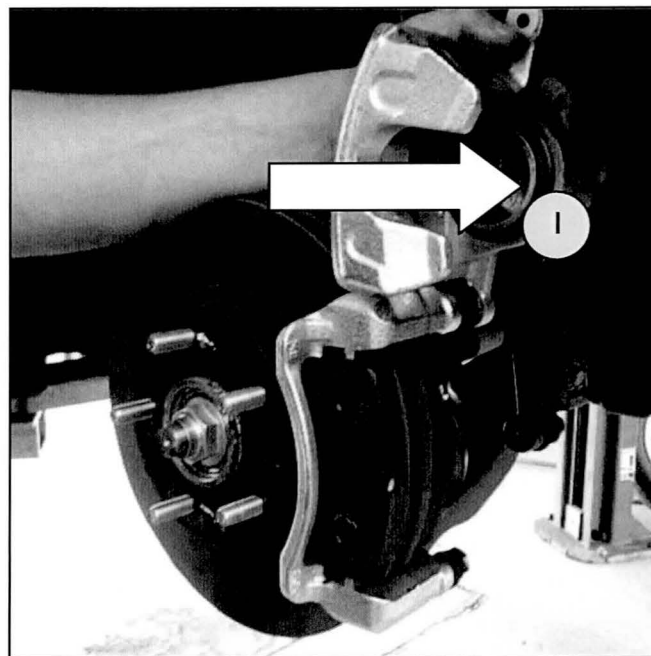

11. Reinstall all the removed parts in reverse order of removal.
12. Replace the left front brake pads with new pads referring to above procedures.