

Service Bulletin

Mazda North American Operations
Irvine, CA 92618-2922



© 2013 Mazda Motor of America, Inc.

Subject: MIL ILLUMINATION WITH DTCs P219A:00 AND/OR P219B:00	Bulletin No: 01-027/13
	Last Issued: 11/12/2013

BULLETIN NOTE

- This bulletin supersedes the previous bulletin 01-027/13, issued on 10/31/13. The REPAIR PROCEDURE has been revised.
- Changes are noted below in Red beside the change bar.

APPLICABLE MODEL(S)/VINS

2011-2013 CX-9

DESCRIPTION

Some vehicles may experience MIL illumination with DTC P219A:00 and/or P219B:00 stored in PCM memory.

DTC	Description
P219A:00	Bank 1 Air-Fuel Ratio Imbalance
P219B:00	Bank 2 Air-Fuel Ratio Imbalance

The DTCs may be caused by abnormal electrical noise within the engine harness of certain vehicles. To eliminate this concern, separate the A/F sensor signal lines from the emission harness by installing the short cord service part detailed in this bulletin.

Customers having this concern should have their vehicle repaired using the following repair procedure.

CONSUMER NOTICE: The information and instructions in this bulletin are intended for use by skilled technicians. Mazda technicians utilize the proper tools/equipment and take training to correctly and safely maintain Mazda vehicles. These instructions should not be performed by "do-it-yourselfers." Customers should not assume this bulletin applies to their vehicle or that their vehicle will develop the described concern. To determine if the information applies, customers should contact their nearest authorized Mazda dealership. Mazda North American Operations reserves the right to alter the specifications and contents of this bulletin without obligation or advance notice. All rights reserved. No part of this bulletin may be reproduced in any form or by any means, electronic or mechanical—including photocopying and recording and the use of any kind of information storage and retrieval system—without permission in writing.

REPAIR PROCEDURE

Summary:

1. Verify that DTC P219A:00 and/or P219B:00 is stored in PCM memory.

NOTE:

- The repairs are slightly different depending on which DTC is stored in PCM memory. Be sure to proceed to the correct repair for the DTC that is found.
 - If both DTCs are stored in PCM memory, complete both repairs in this bulletin.
2. Remove (pull out) four (4) terminals from PCM connector 0140-010B.
 3. Replace the four (4) removed terminals with the correct four (4) short cord terminals.
 4. Route the short cord (A) from connector 0140-010B and the A/F sensor connector 0140-24 (for DTC P219A:00) OR connector 0140-25 (for DTC P219B:00).

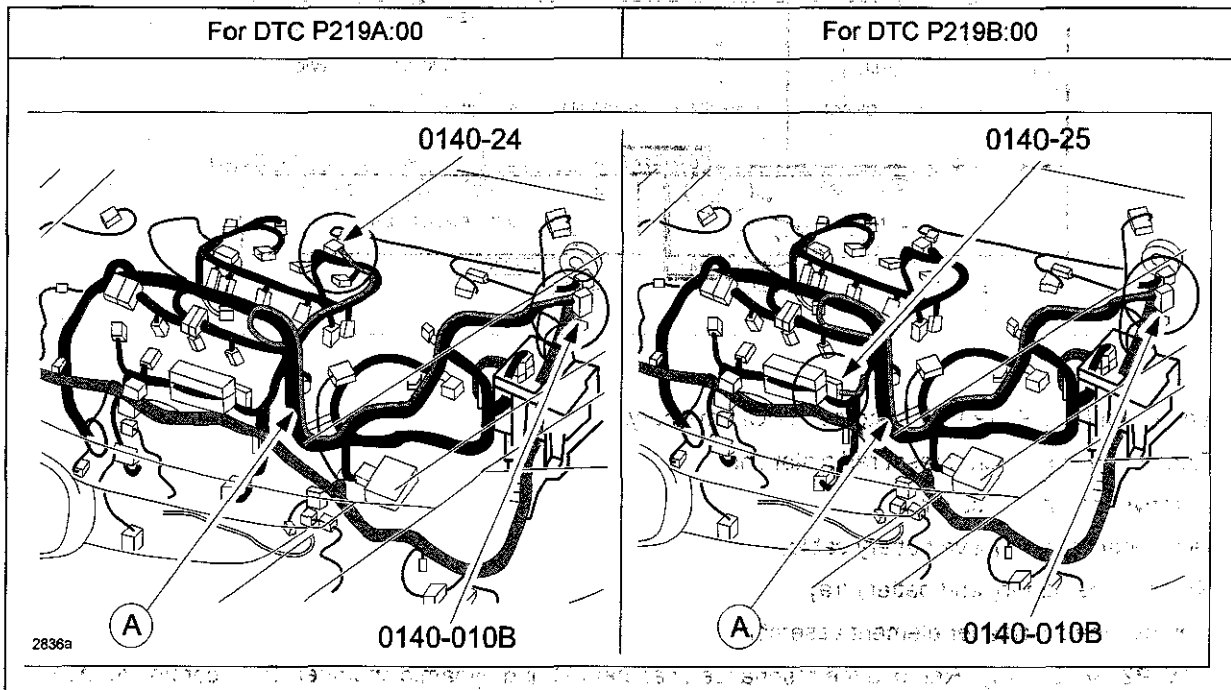

5. Pull out two (2) A/F Sensor terminals (C and E) from connector 0140-24 (for DTC P219A:00) OR connector 0140-25 (for DTC P219B:00), then install them into the short cord connector.

REPAIR PROCEDURE FOR DTC P219A:00:

Wiring Diagram:

(A) = Install short cord

(B) = A/F Sensor (RH) terminals C and E

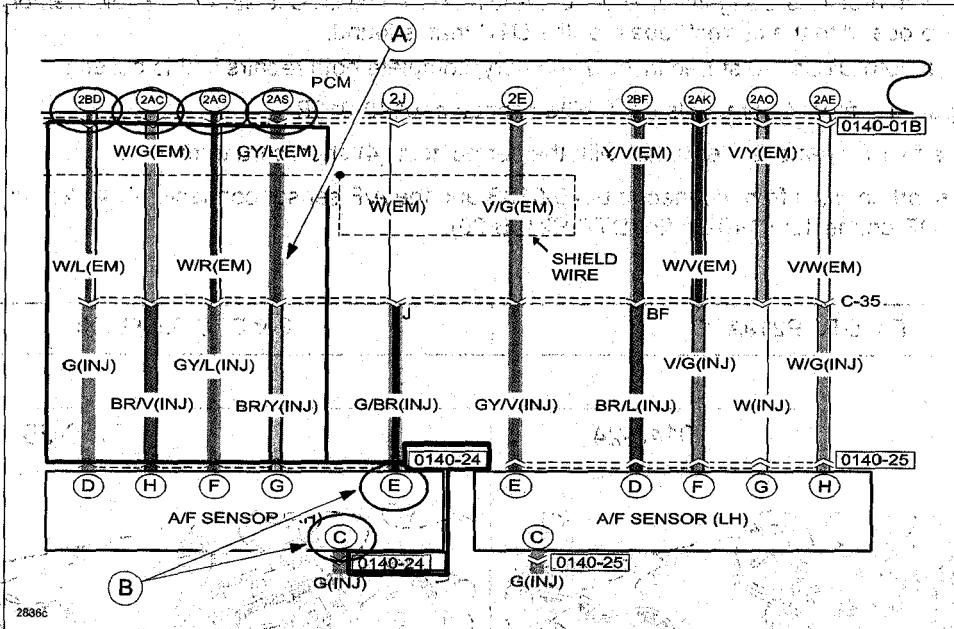

1. Verify that DTC P219A:00 is stored in PCM memory.
2. Record the customers preset radio stations.
3. Remove the engine cover.
4. Disconnect the negative battery cable.
5. Remove the battery and battery tray.
6. Remove the air cleaner element assembly.
7. **DTC P219A:00 only:** Remove the resonance chamber (A) and dynamic chamber (B) according to MS3 online instructions or the Workshop Manual (section 01-13 INTAKE-AIR SYSTEM REMOVAL/INSTALLATION [MZI-3.7]).

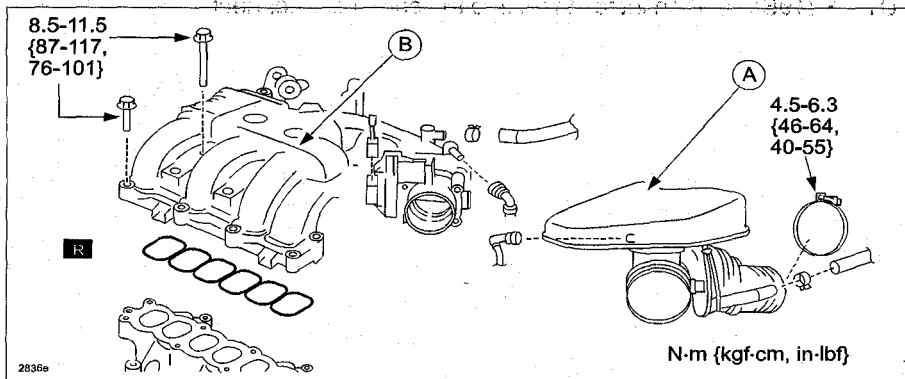

8. Disconnect connector 0140-010B from the PCM.
9. Remove the four (4) terminals (shown below) from connector 0140-010B.

NOTE: Refer to "How to remove terminals" below.

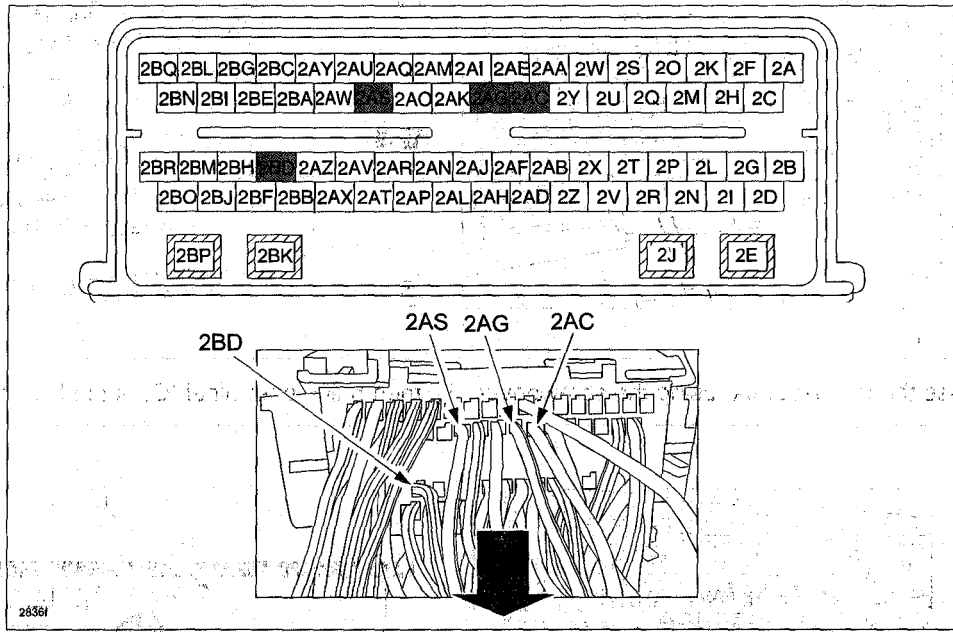

No.	Terminal	Wire Color
1	2BD	White/Blue
2	2AS	Gray/Blue
3	2AG	White/Red
4	2AC	White/Green

How to remove terminals:

- a. Lift up the lock cover (A) using a thin flat-blade screwdriver (B), then remove cover from connector.

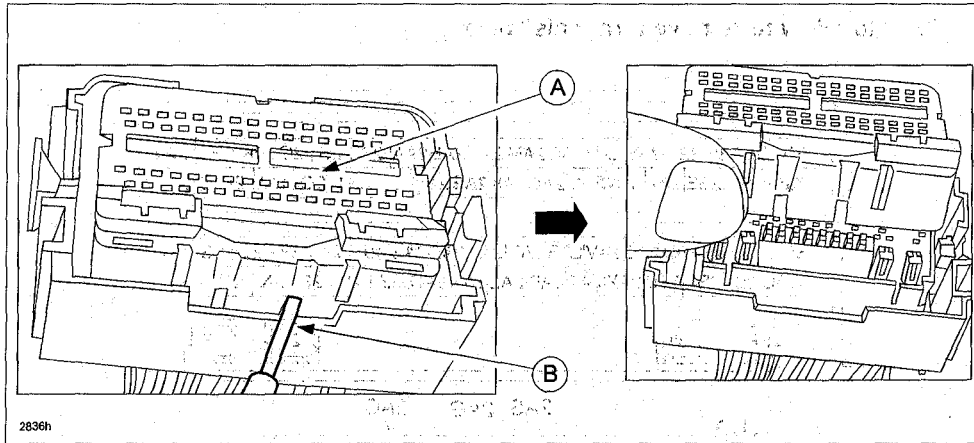

- b. Release the lock lever (A) using the screwdriver (B), then pull the terminal (C) out of the connector.

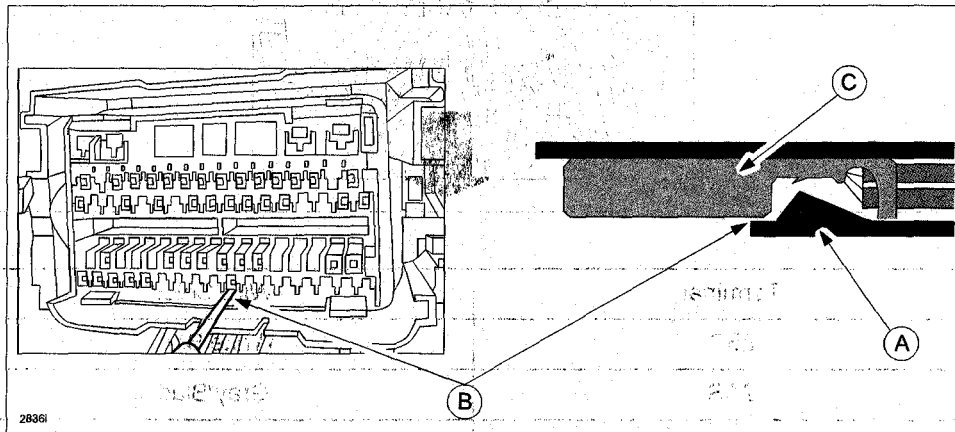

10. Install the four (4) terminals (shown below) from the short cord into the removed terminals from connector 0140-010B. Refer to the below table for terminal location and short cord wire colors.

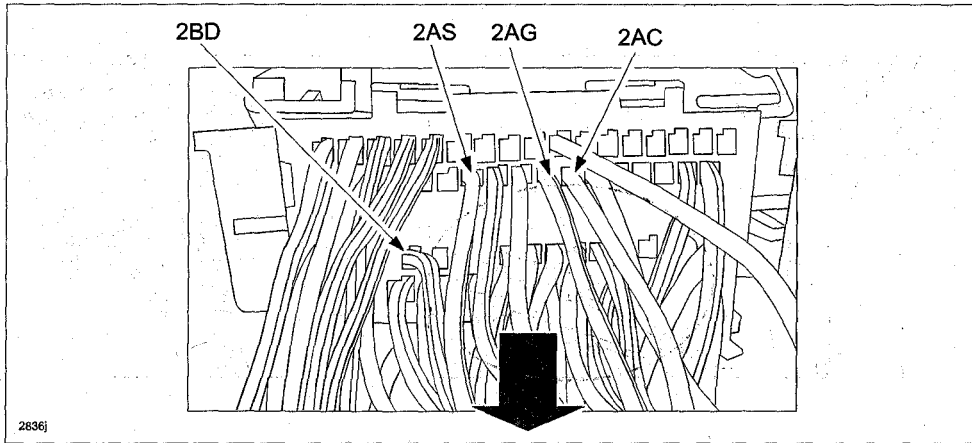

No.	Terminal	Wire Color	Short Cord Wire Color
1	2BD	White/Blue	Brown/Blue
2	2AS	Gray/Blue	White
3	2AG	White/Red	Violet/Green
4	2AC	White/Green	White/Green

11. Insert the lock cover over the connector, then push the cover down as shown below.

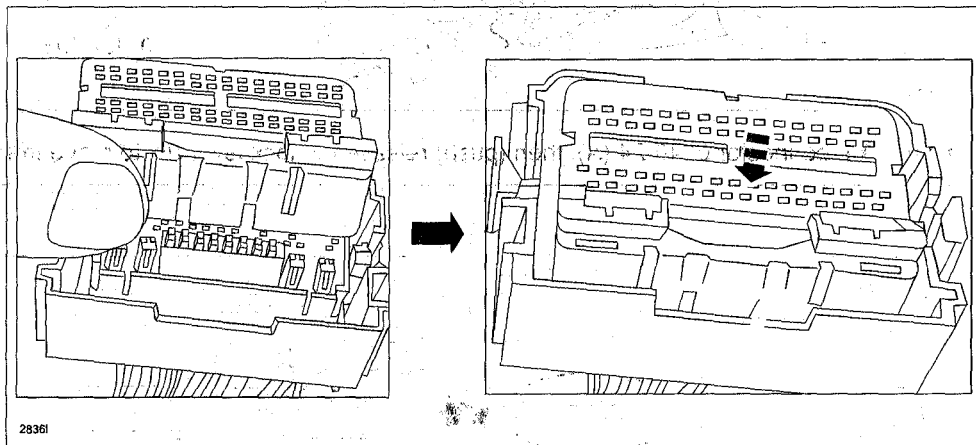

12. Tape the remaining four (4) terminals of connector 0140-010B with electrical tape; then attach them to the harness as shown below.

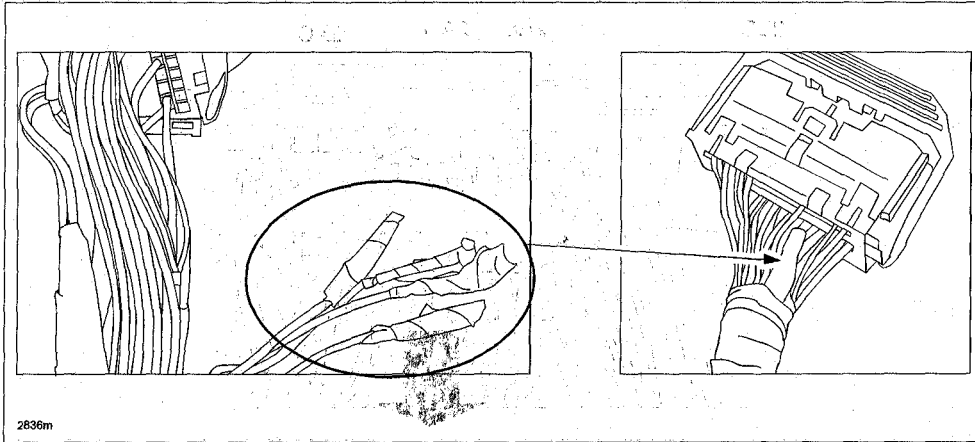

13. Route the short cord (A) as shown below.

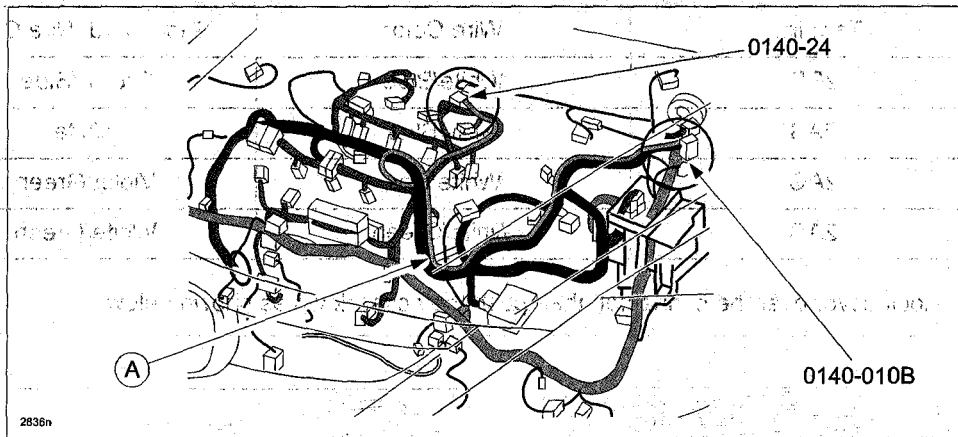

14. Disconnect the A/F connector 0140-24 (A), then (push) release the lock lever (B) to move from the harness.

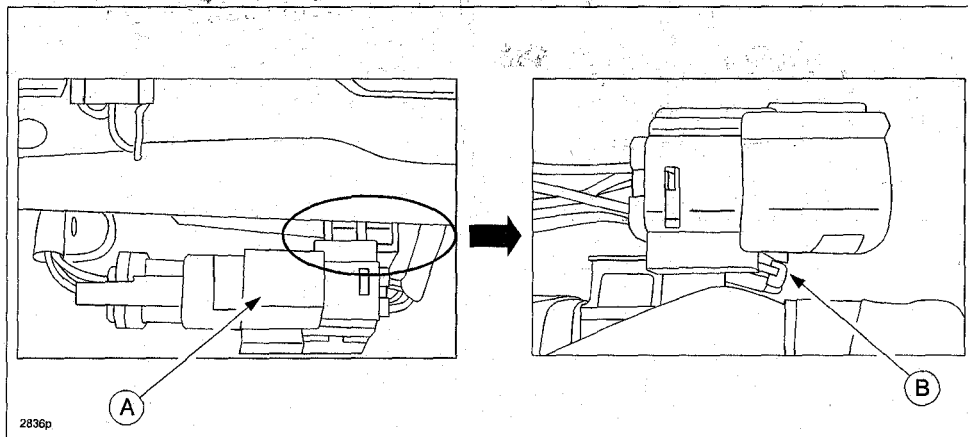

15. Remove terminals C (Green) and E (Green/Brown) from connector 0140-24.

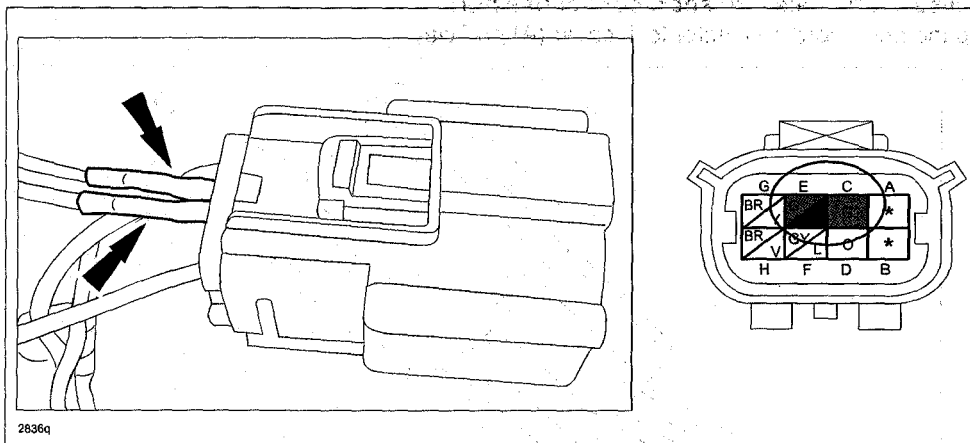

How to remove terminals:

- a. Lift up the lock cover (A) using a thin flat-blade screwdriver, then remove cover from connector.

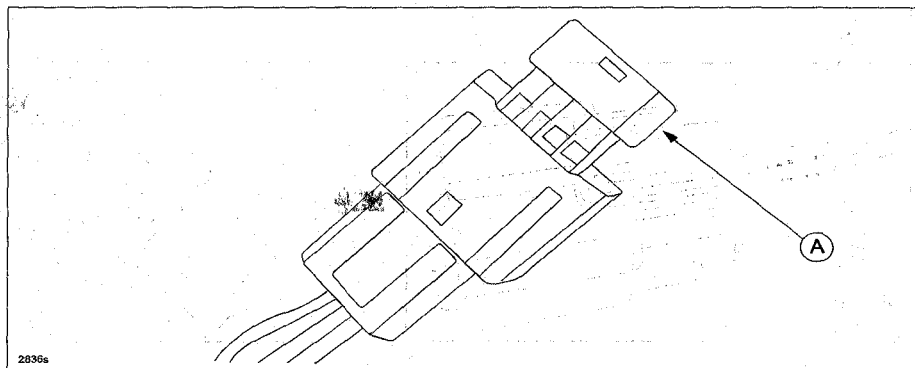

- b. Release the lock lever using the screwdriver, then pull the terminal out of the connector.

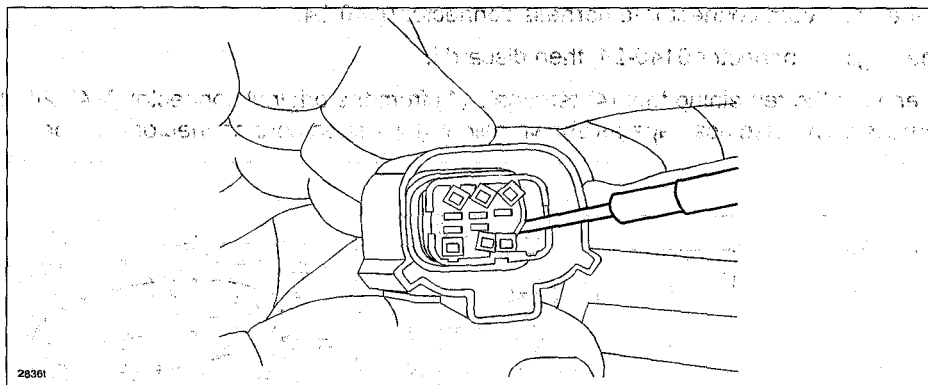

16. Insert the removed terminals from connector 0140-24 into the short cord connector.

How to insert terminals into short cord connector:

- a. Lift up the short cord connector lock cover (A) half way.

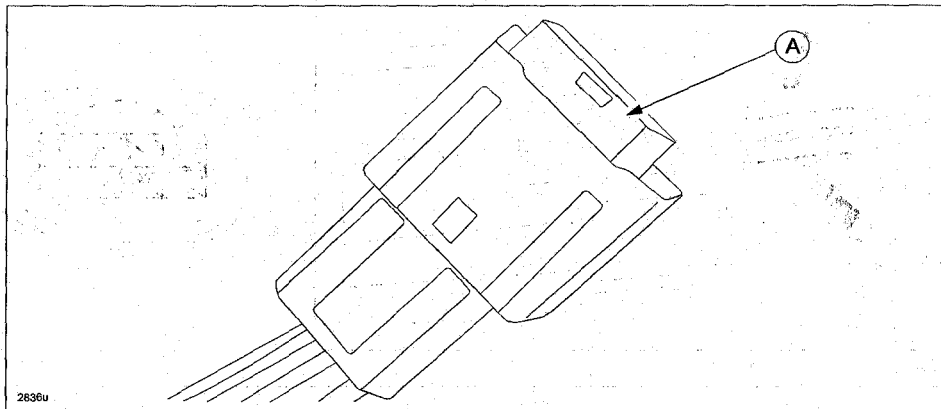

- b. Insert the terminals (A) into the connector, then push the lock cover down.

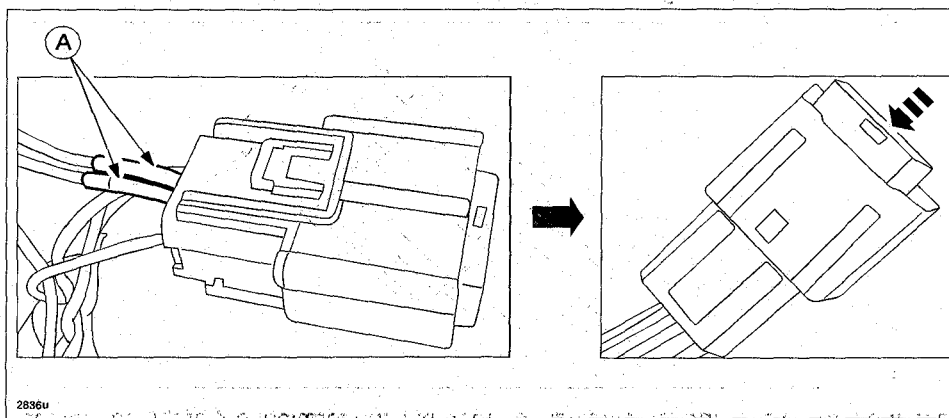

17. Connect the short cord connector to harness connector 0140-24.

18. Cut off the original connector 0140-24, then discard it.

19. Tape the ends of the remaining four (4) terminals (A) from the original connector 0140-24, then attach them to the harness using electrical tape as shown below. (B) = short cord connector location.

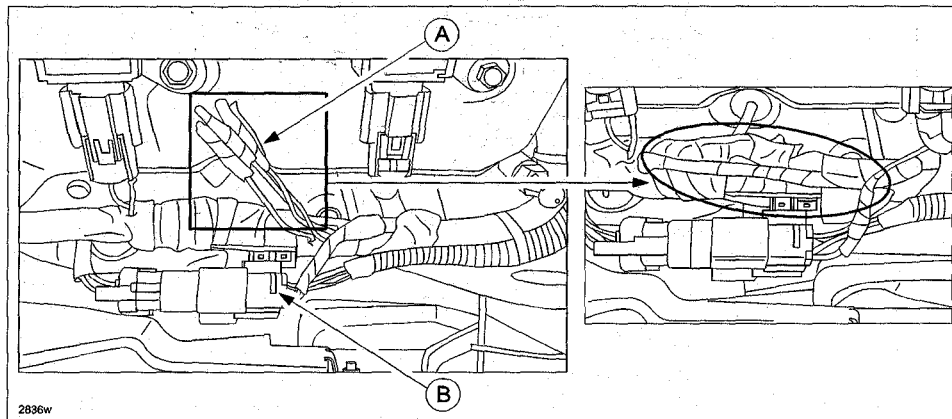

20. Using black tie-wraps (A), attach the short cord to the harness as shown below.

a. PCM side:

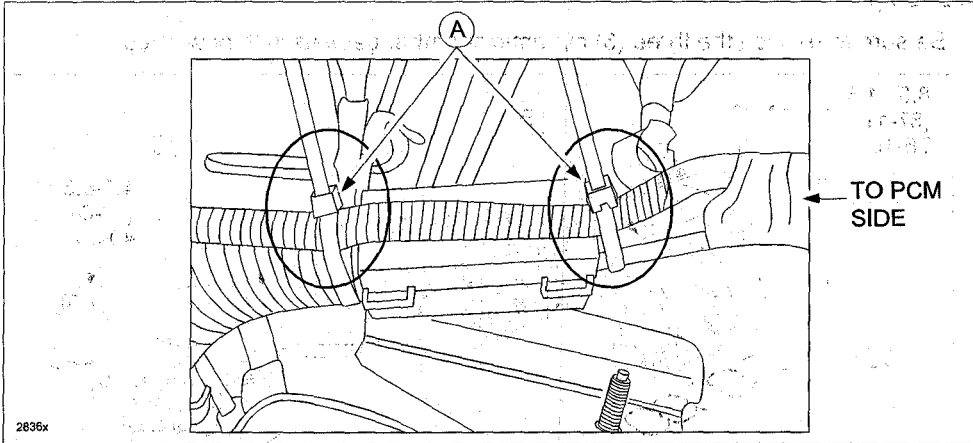

b. Starter motor side:

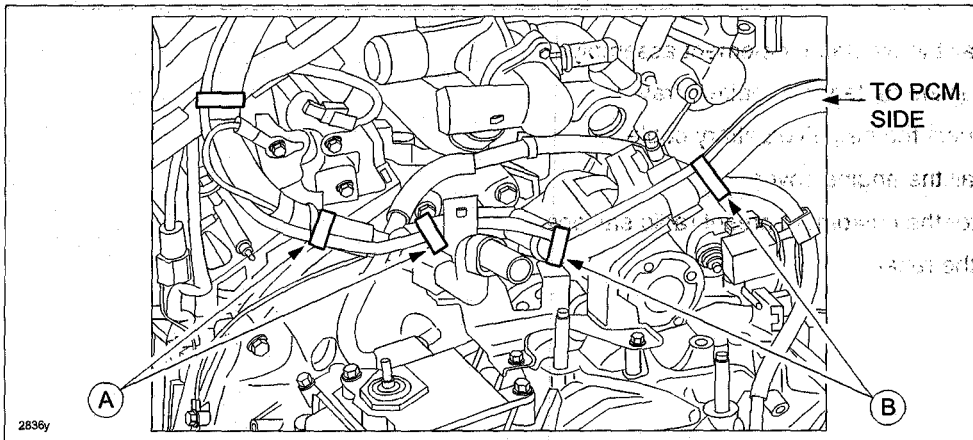

c. On Engine:

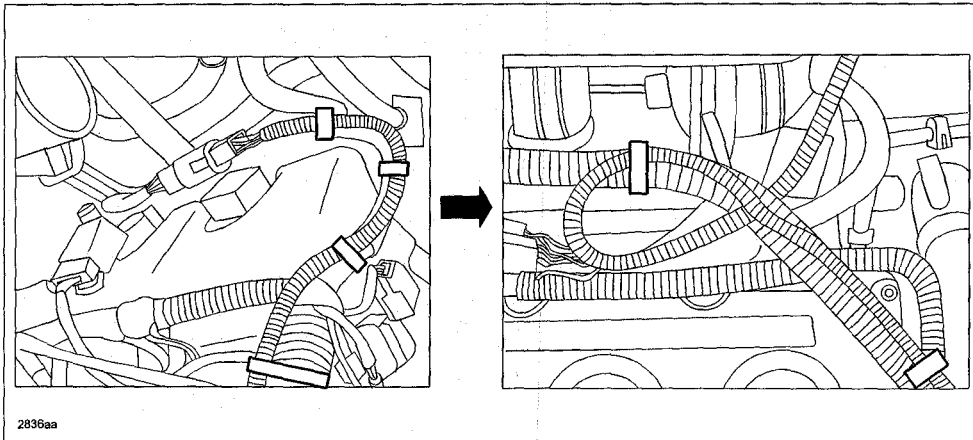

21. **DTC P219A:00 only:** Reinstall the resonance chamber (A) and dynamic chamber (B) according to MS3 online instructions or the Workshop Manual (section 01-13 INTAKE-AIR SYSTEM REMOVAL/INSTALLATION [MZI-3.7]).

NOTE: Be sure to replace the three (3) dynamic chamber gaskets with new ones.

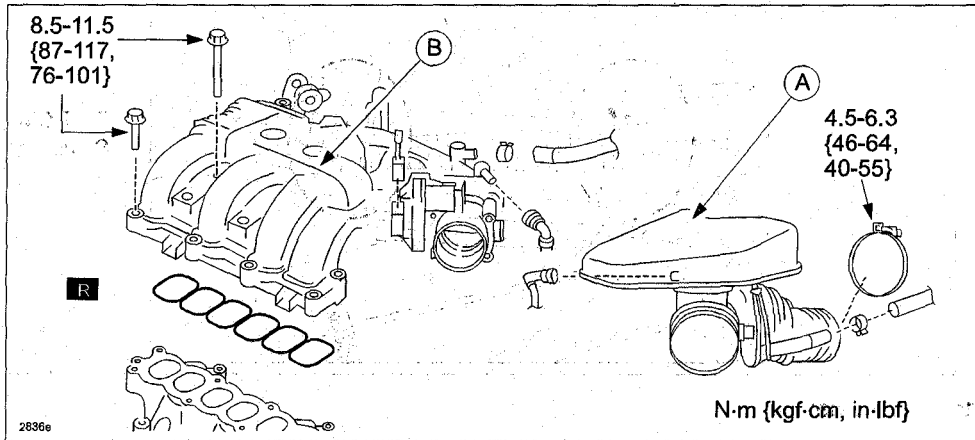

22. Reinstall the air cleaner element assembly.
23. Reinstall the battery and battery tray.
24. Reconnect the negative battery cable.
25. Reinstall the engine cover.
26. Re-enter the customers preset radio stations.
27. Verify the repair.

REPAIR PROCEDURE FOR DTC P219B:00:

Wiring Diagram:

(A) = Install short cord

(B) = A/F Sensor (LH) terminals C and E

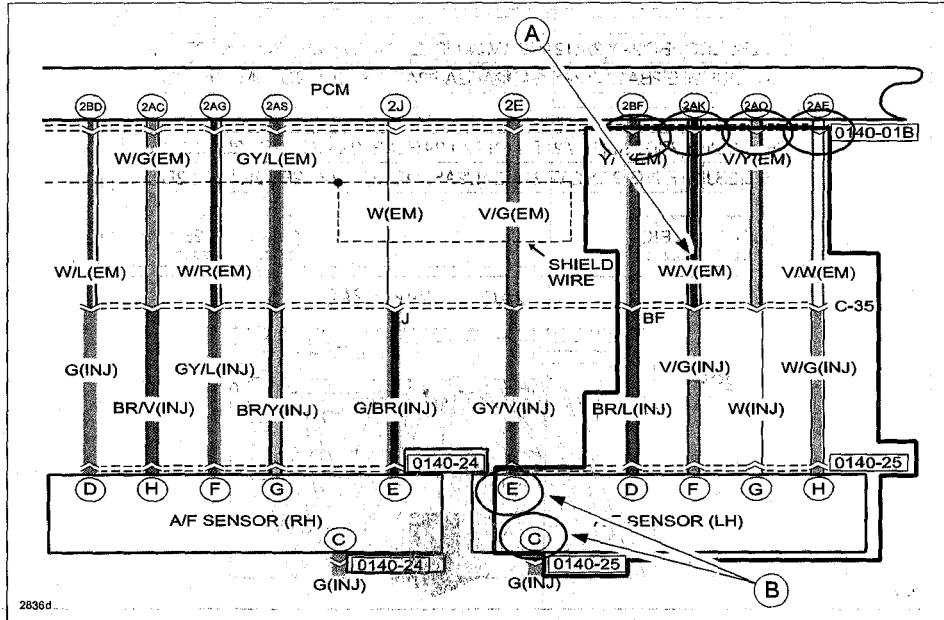

1. Verify that DTC P219B:00 is stored in PCM memory.
2. Record the customers preset radio stations.
3. Remove the engine cover.
4. Disconnect the negative battery cable.
5. Remove the battery and battery tray.
6. Remove the air cleaner element assembly.

7. Disconnect connector 0140-010B from the PCM.
8. Remove the four (4) terminals (shown below) from connector 0140-010B.

NOTE: Refer to "How to remove terminals" below.

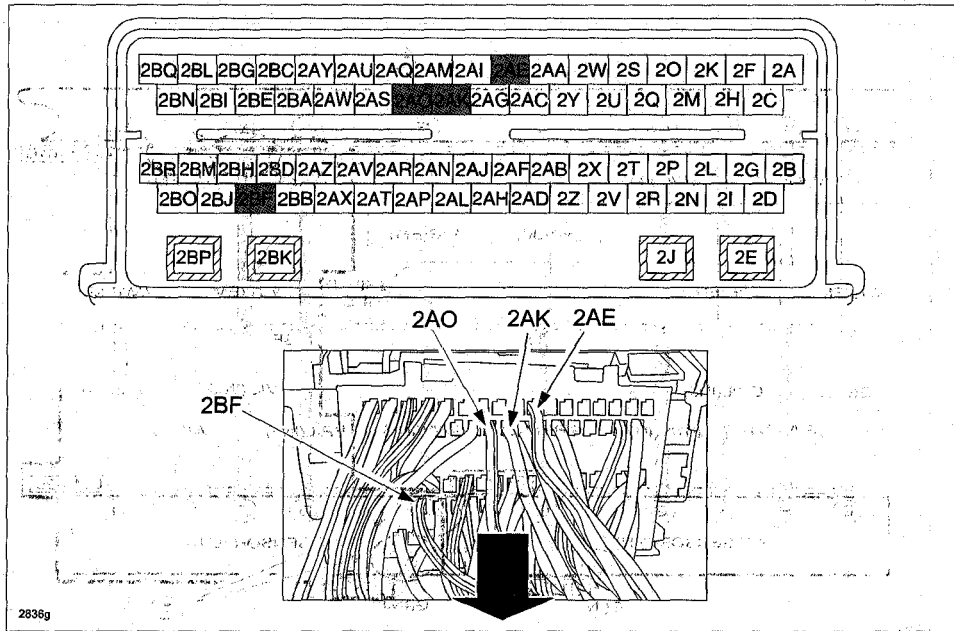

No.	Terminal Location	Wire Color
1	2BF	Yellow/Violet
2	2AO	Violet/Yellow
3	2AK	White/Violet
4	2AE	Violet/White

How to remove terminals:

- a. Lift up the lock cover (A) using a thin flat-blade screwdriver (B), then remove cover from connector.

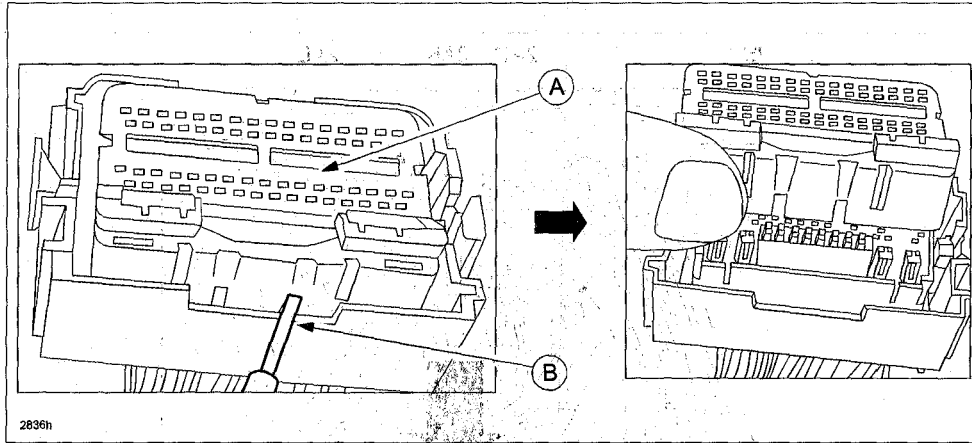

- b. Release the lock lever (A) using the screwdriver (B), then pull out the terminal (C) out of the connector.

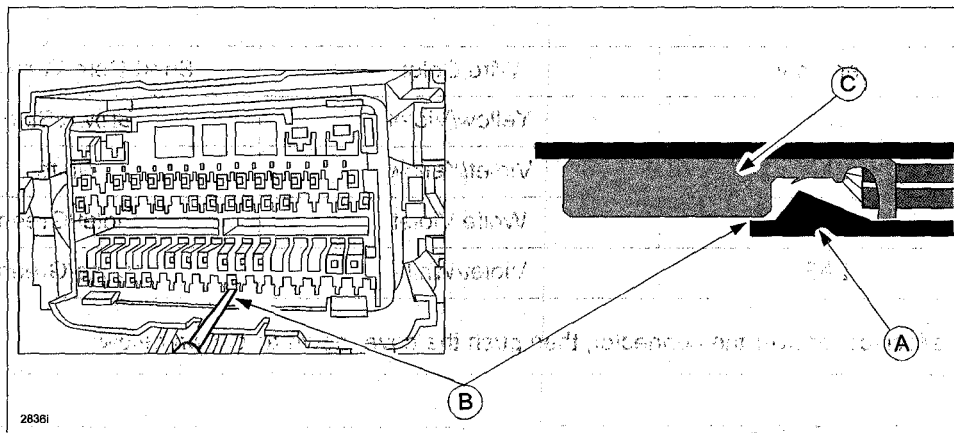

9. Insert the four (4) terminals from the short cord into the removed terminals from connector 0140-010B. Refer to the below table for terminal location and short cord wire colors.

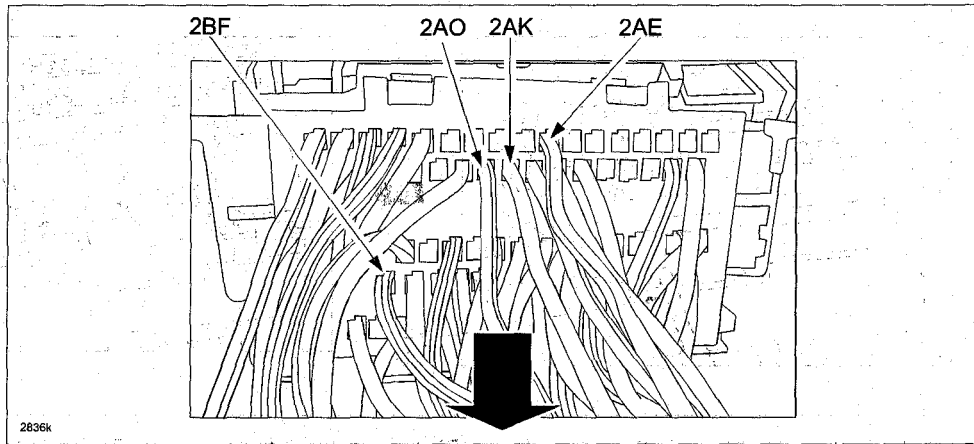

No.	Terminal	Wire Color	Short Cord Wire Color
1	2BF	Yellow/Violet	Brown/Blue
2	2AO	Violet/Yellow	White
3	2AK	White/Violet	Violet/Green
4	2AE	Violet/White	White/Green

10. Insert the lock cover over the connector, then push the cover down as shown below.

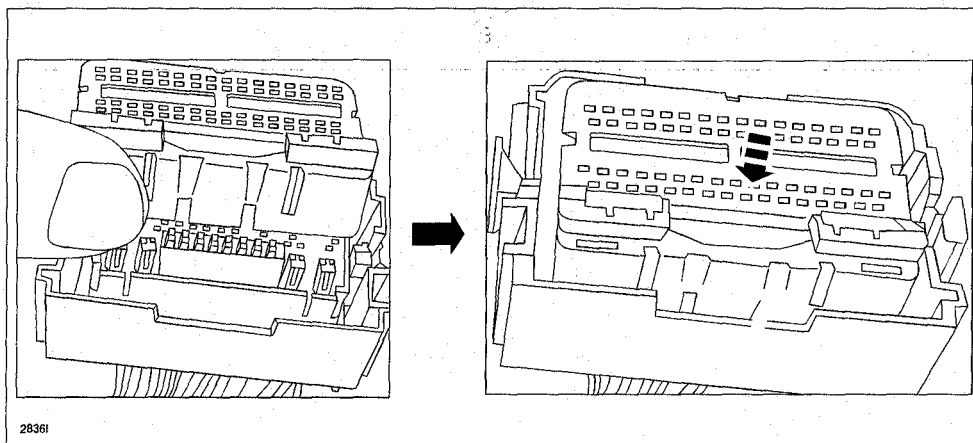

11. Tape the remaining four (4) terminals of connector 0140-010B with electrical tape, then attach them to the harness as shown below.

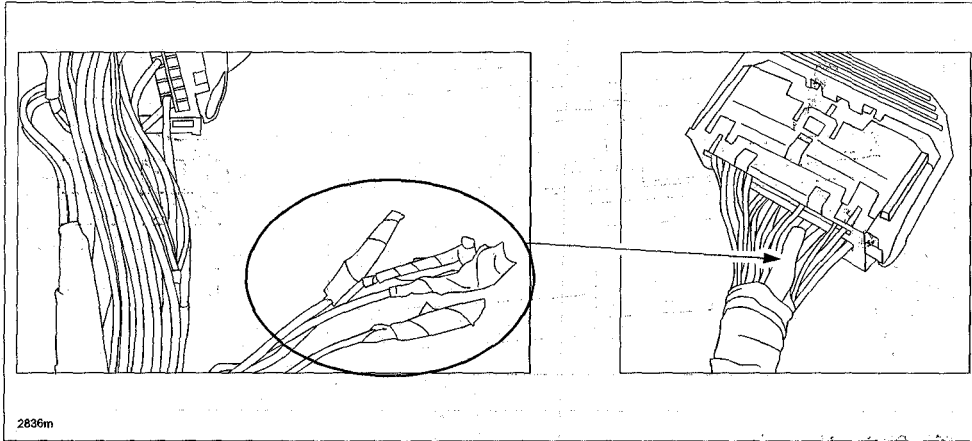

12. Route the short cord (A) as shown below.

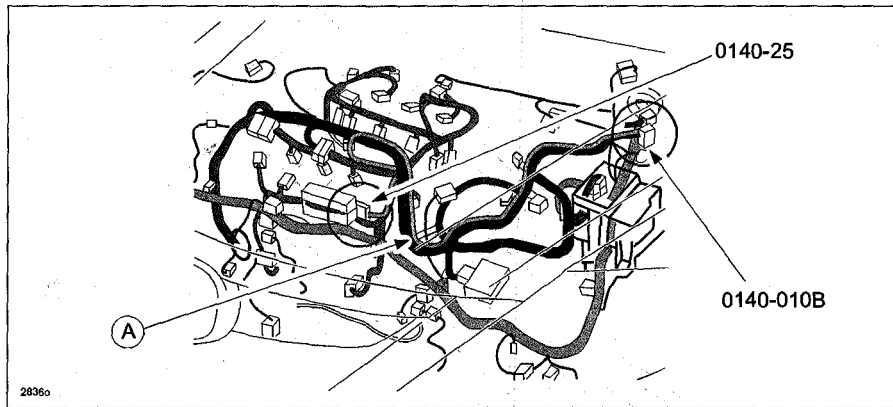

13. Disconnect the A/F connector 0140-25 (A), then (push) release the lock lever (B) to move from the harness.

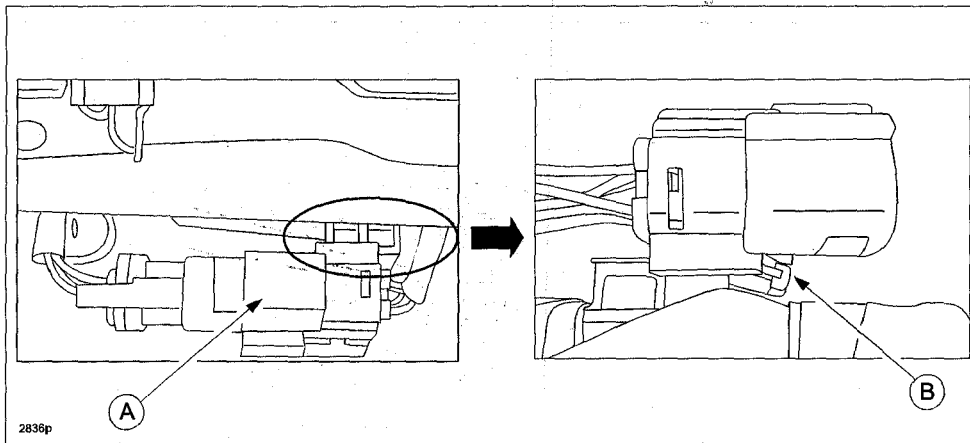

14. Remove terminals C (Green) and E (Gray/Violet) from connector 0140-25.

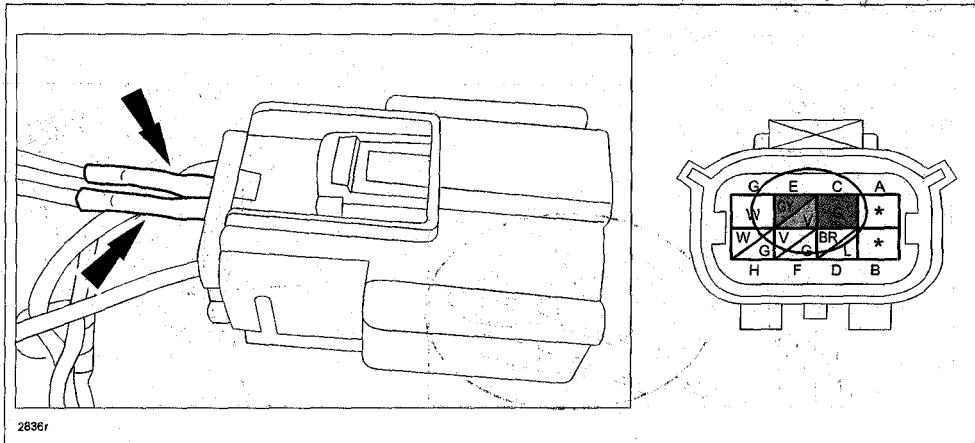

How to remove terminals:

- a. Lift up the lock cover (A) using a thin flat-blade screwdriver, then remove cover from the connector.

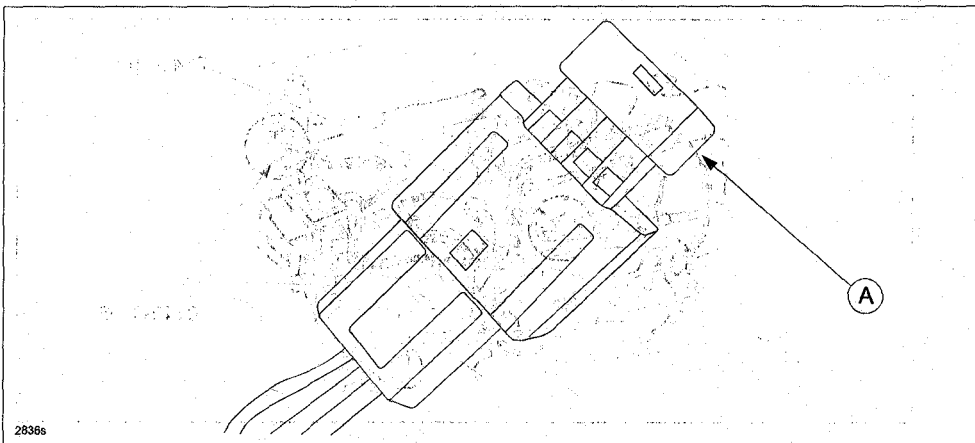

- b. Release the lock lever using the screwdriver, then pull out the terminal out of the connector.

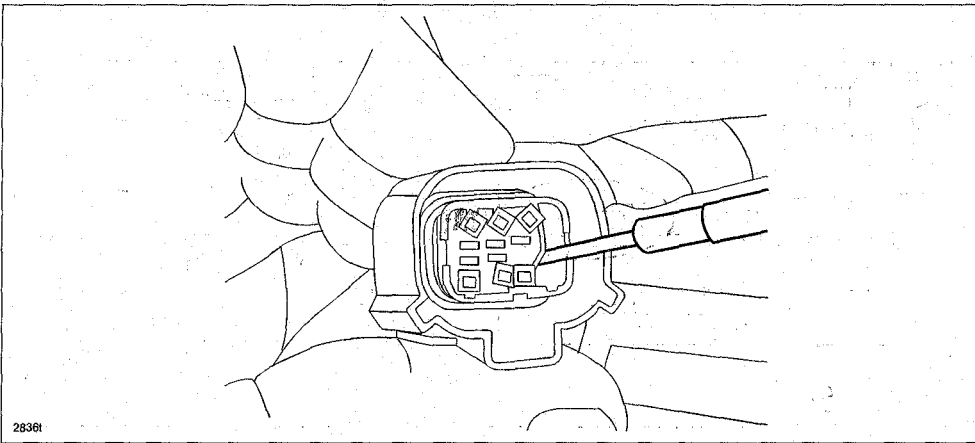

15. Insert the removed terminals from connector 0140-25 into the short cord connector.

How to insert terminals into short cord connector:

- a. Lift up the short cord connector lock cover (A) half way.

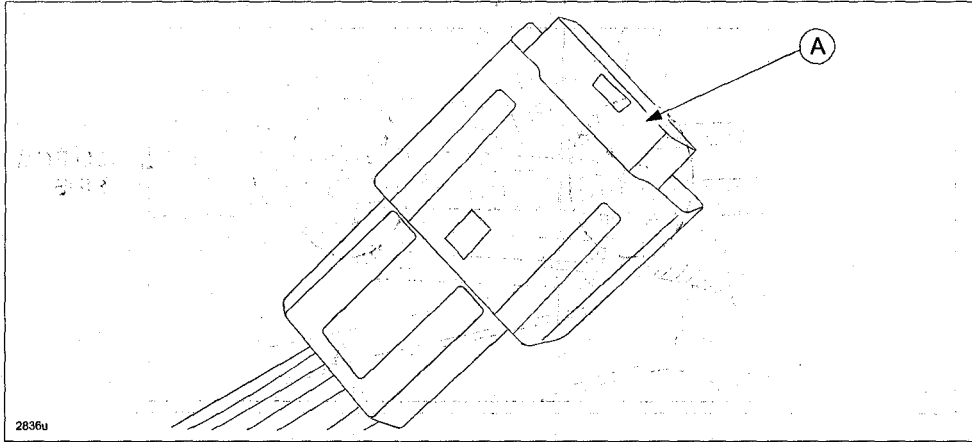

- b. Insert the terminals (A) into the connector, then push the lock cover down.

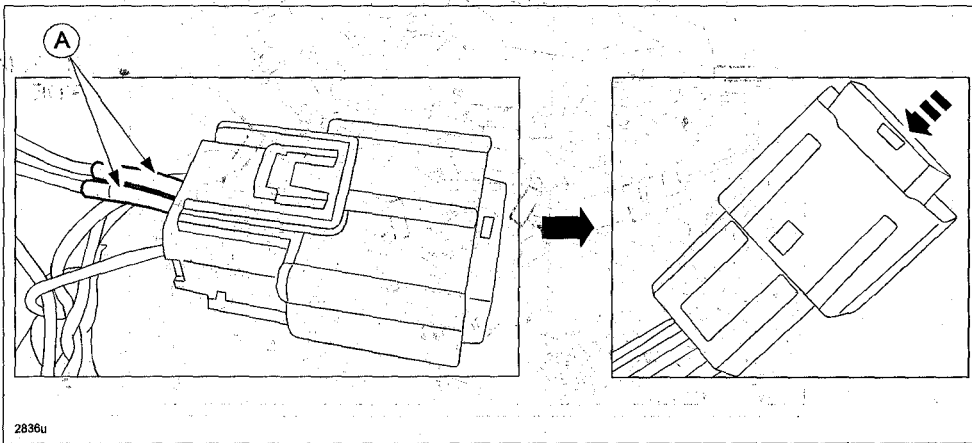

16. Connect the short cord connector to harness connector 0140-25.

17. Cut off the original connector 0140-25, then discard it.

18. Tape the ends of the remaining four (4) terminals (A) from the original connector 0140-25 and attach them to the harness using electrical tape as shown below. (B) = short cord connector location.

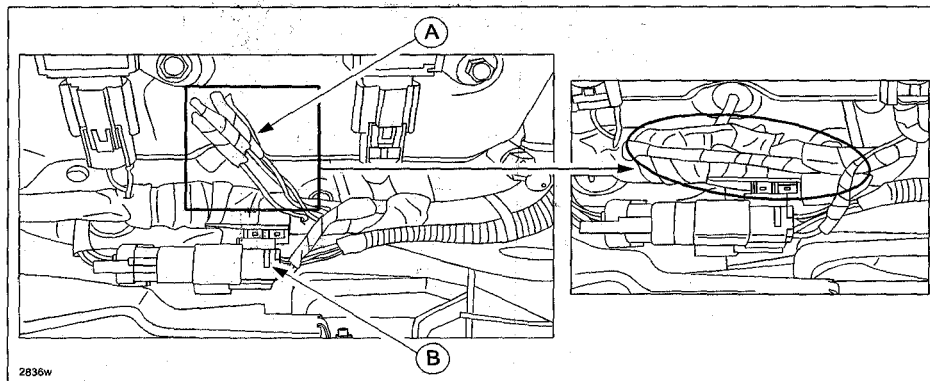

19. Using black tie-wraps (A), attach the short cord to the harness as shown below.

a. PCM side:

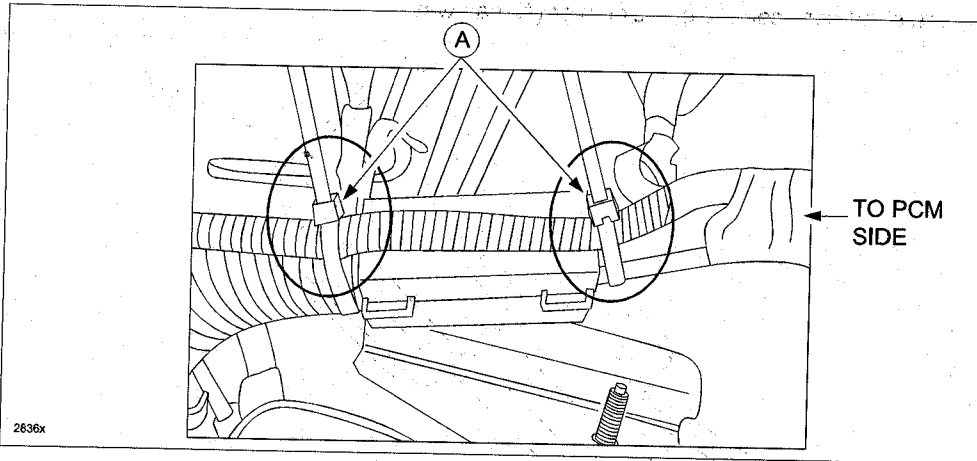

b. Starter motor side:

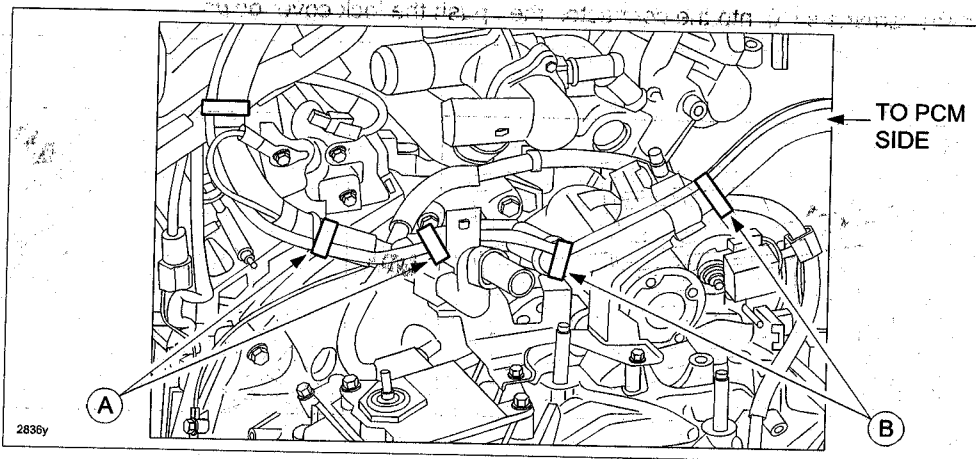

c. On engine:

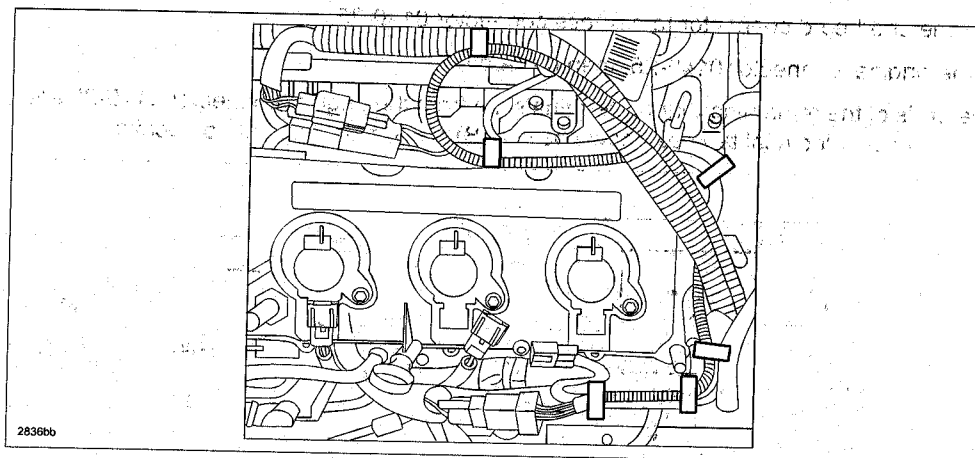

Bulletin No: 01-027/13
© 2013 Mazda Motor of America, Inc.

Last Issued: 11/12/2013

20. Reinstall the air cleaner element assembly.
21. Reinstall the battery and battery tray.
22. Reconnect the negative battery cable.
23. Reinstall the engine cover.
24. Re-enter the customers preset radio stations.
25. Verify the repair.

PART(S) INFORMATION

Part Number	Description	Qty	Notes
TGY1-67-SH1	Short Cord	1 or 2	For DTCs P219A:00 and/or P219B:00
CY01-13-135	Gasket	3	Replacement parts for DTC P219A:00 repair only

WARRANTY INFORMATION

NOTE:

- This warranty information applies only to verified customer complaints on vehicles eligible for warranty repair.
- This repair will be covered under Mazda's New Vehicle Limited Warranty term or California Emission Defects Warranty (Long Term).
- Additional diagnostic time cannot be claimed for this repair.

Warranty Type	A
Symptom Code	14
Damage Code	9Q
DTC	P219A:00 - (for DTC P219A:00) P219B:00 - (for DTC P219B:00) P219A:00 - (for DTC P219A:00 and P219B:00)
Part Number Main Cause	TGY1-67-SH1
Quantity	1 or 2
Operation Number / Labor Hours:	XXJCHXR / 1.5 Hrs. - (for DTC P219A:00 only) XXJCJXR / 0.9 Hrs. - (for DTC P219B:00 only) XXJCKXR / 1.9 Hrs. - (for DTC P219A:00 and P219B:00)