

© 2013 Mazda Motor of America, Inc.

Subject: SQUEAK NOISE FROM ENGINE COMPARTMENT	Bulletin No: 01-013/13
	Last Issued: 05/28/2013

BULLETIN NOTE

- This bulletin supersedes the previous bulletin 01-021/12 issued on 07/17/12, 08/24/12 and 11/28/12. The **APPLICABLE MODEL(S)/VINS, DESCRIPTION, REPAIR PROCEDURE, PARTS, and WARRANTY INFORMATION** have been revised.
- Changes are noted below in Red beside the change bar.

APPLICABLE MODEL(S)/VINS

2010-2013 Mazda3 (including 2.0L SKYACTIV) **vehicles with VINs lower than JM1 BL ***** 820323 (produced before April 9, 2013)**

2012-2013 Mazda5 vehicles with VINs lower than JM1 CW *** 158910 (produced before April 9, 2013)**

DESCRIPTION

Some vehicles may exhibit a squeak noise from the engine compartment when the vehicle starts moving and/or at the time of transmission shifting. This is caused by stick-slip noise occurring at the contact surfaces between the No. 4 engine mount rubber and the No. 4 engine mount bracket when the engine shakes back and forth.

Customers having this concern should have their vehicle repaired using the following repair procedure.

REPAIR PROCEDURE

1. Verify customer concern.
2. Remove the No. 4 engine mount rubber (A) from the No. 4 engine mount bracket (B). Refer to MS3 online instructions or Workshop Manual:
 - Mazda3 SKYACTIV - (section 01-10 ENGINE REMOVAL/INSTALLATION [SKYACTIV-G 2.0]).
 - Mazda3 MZR 2.0, 2.5 - (section 01-10 ENGINE REMOVAL/INSTALLATION [MZR 2.0, MZR 2.5]).
 - **Mazda5 - (section 01-10 ENGINE REMOVAL/INSTALLATION [MZR 2.5]).**
3. Clean the surfaces of the No. 4 engine mount bracket (C) where it contacts the mount rubber.

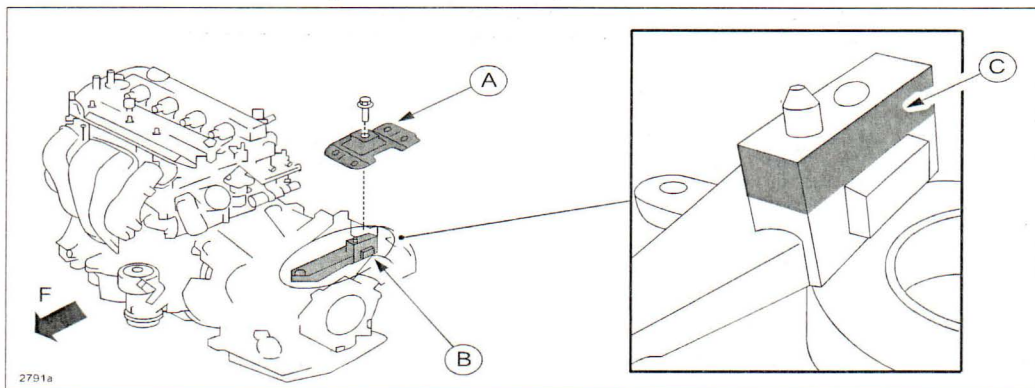

Page 1 of 3

CONSUMER NOTICE: The information and instructions in this bulletin are intended for use by skilled technicians. Mazda technicians utilize the proper tools/equipment and take training to correctly and safely maintain Mazda vehicles. These instructions should not be performed by "do-it-yourselfers." Customers should not assume this bulletin applies to their vehicle or that their vehicle will develop the described concern. To determine if the information applies, customers should contact their nearest authorized Mazda dealership. Mazda North American Operations reserves the right to alter the specifications and contents of this bulletin without obligation or advance notice. All rights reserved. No part of this bulletin may be reproduced in any form or by any means, electronic or mechanical---including photocopying and recording and the use of any kind of information storage and retrieval system ---without permission in writing.

4. Install the new mount rubber (A) on the No. 4 engine mount bracket (B).

NOTE: Install the mount rubber (A) with the notched side facing down.

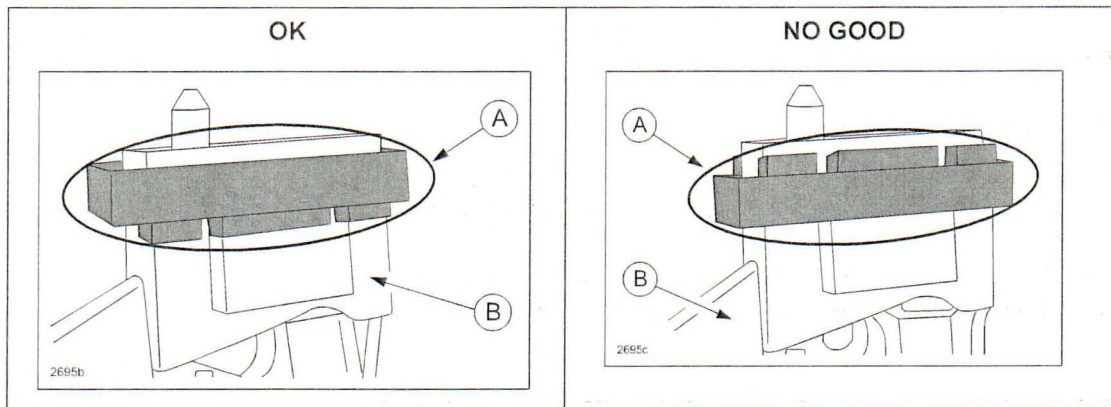

5. **Remove the original mount rubber from the No.4 engine mount rubber and clean surfaces of the No.4 engine mount rubber where it contacts with the new mount rubber.**
6. Install the No. 4 engine mount rubber (F=front).
7. Install other removed parts in the reverse order of removal.
8. Verify repair.

Bulletin No: 01-013/13 © 2013 Mazda Motor of America, Inc.	Last Issued: 05/28/2013
---	-------------------------

PART(S) INFORMATION

Part Number	Description	Qty.
BBM4-39-074	Mount Rubber	1

WARRANTY INFORMATION

NOTE:

- This warranty information applies only to verified customer complaints on vehicles eligible for warranty repair.
- This repair will be covered under Mazda's Powertrain Limited Warranty term.
- Additional diagnostic time cannot be claimed for this repair.

	Mazda3	Mazda5
Warranty Type	A	A
Symptom Code	82	82
Damage Code	97	97
Part Number Main Cause	BBM4-39-074	BBM4-39-074
Quantity	1	1
Operation Number / Labor Hours:	XXH5RXRX / 0.7 Hrs. (2.0L and 2.5L) XXH5SXRX / 0.8 Hrs. (2.0L SKYACTIV-G)	XXH7CXRX / 1.0 Hrs.