

Technical Service Bulletin

Topic	Air Bag Warning - Resistance Related Fault Codes
Market area	United States E05 Bentley USA and rest America (6E05)
Brand	Bentley
Transaction No.	2033170/2
Level	EH
Status	Released for publishing
Release date	Dec 20, 2013

New customer code

Object of complaint	Complaint type	Position
Information, navigation, communication, entertainment -> Malfunction display symbols -> Airbag\belt tensioner system malfunction display	Functionality -> Activates	

New workshop code

Object of complaint	Complaint type	Position
Occupant protection, passenger protection -> Seat belts -> Three-point seat belt -> Belt force limiter igniter	Electrical -> Resistance too high	
Occupant protection, passenger protection -> Seat belts -> Three-point seat belt -> Belt tensioner igniter	Electrical -> Resistance too high	Left
Occupant protection, passenger protection -> Seat belts -> Three-point seat belt -> Belt tensioner igniter	Electrical -> Resistance too high	Right
Occupant protection, passenger protection -> Seat belts -> Three-point seat belt -> Belt force limiter igniter	Electrical -> Resistance too low	
Occupant protection, passenger protection -> Seat belts -> Three-point seat belt -> Belt tensioner igniter	Electrical -> Resistance too low	Left
Occupant protection, passenger protection -> Seat belts -> Three-point seat belt -> Belt tensioner igniter	Electrical -> Resistance too low	Right

Vehicle data

Continental GTC derivatives 11MY,12MY,13MY USA. not New GT

Sales types

Type	MY	Brand	Designation	Engine code	Gearbox code	Final drive code
3W4*	2011	E		*	*	*
3W4*	2012	E		*	*	*
3W4*	2013	E		*	*	*
3W7*	2011	E		*	*	*
3W7*	2012	E		*	*	*
3W7*	2013	E		*	*	*

Chassis numbers

Manufacturer	Filler	Type	Filler	MY	Factory	From	To	Prod from	Prod to
SCB	***	ZA	*	B	C	063745	999999		
SCB	***	ZA	*	C	C	063745	999999		
SCB	***	ZA	*	D	C	063745	999999		

Documents

Document name
master.xml
master_751375_en-gb.doc

■

Condition

Air bag warning displayed

Technical Background

Specific electrical resistance fault codes may periodically be recorded and subsequently read during service diagnostic procedures

The fault codes displayed relevant to this concern are detailed below:

00654 (driver side pre-tensioner) - 001 Upper limit exceeded

002 Lower limit not reached

007 Short to ground

00655 (passenger side) - 001 Upper limit exceeded

002 Lower limit not reached

007 Short to ground

01740 (driver side load limiter) - 001 Upper limit exceeded

002 Lower limit not reached

007 Short to ground

01741 (passenger side) - 001 Upper limit exceeded

002 Lower limit not reached

007 Short to ground

To prevent this occurrence a reduced electrical resistance wiring harness is available. This new service harness removes the intermediate connections thus reducing the electrical resistance in this circuit avoiding unnecessary warnings being displayed and reducing diagnostic time for resistance related fault codes

Production Solution

Service

To be applied to applicable cars exhibiting fault codes as detailed above. Although the fault codes may only be pertaining to one side of the car at the time of complaint the new harness must be fitted in its entirety, integrated into both the drivers and front passengers seat belt reel assembly.

The procedure consists of electrically disconnecting the original wires connecting the air bag control module to the front seat belt reels. This is done by cutting off the ends of the connectors at the seat belt reel end and de-pinning the main connector housing at the control module end, the redundant wires are then taped back into the main harness. The new harness is then connected to the components and secured to the main harness.

□

The following illustrations show a front centre console fitted in a 4 seat car. However, the general remove and fit procedures apply to all cars, except where shown.

1. Remove the infotainment unit. Rep. Gr 91 Infotainment and navigation unit (RX1) - To remove and fit
2. Remove the front centre console

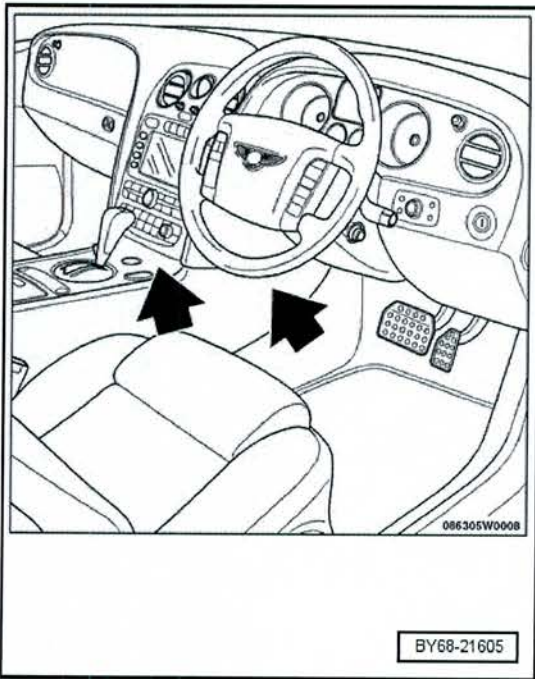

Figure 1

3. Note the front centre console is secured to the dashboard by two side buttons and two screws located under the facia panel, arrows figure 1

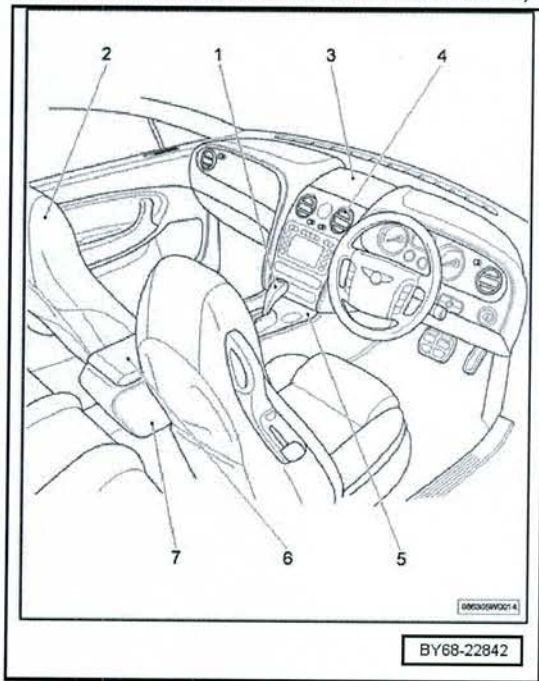

Figure 2

4. Move the gear selector (1) into the 'D' (drive) position
5. Remove the front console facia panel (5) Rep. Gr 68.
6. Remove the centre console armrest (6) Rep. Gr 68
7. Remove the rear centre console (7) Rep. Gr 68

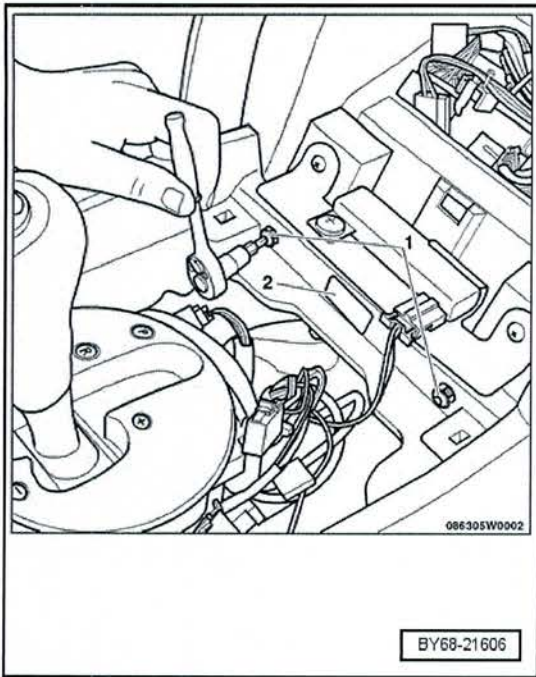

Figure 3

8. Remove the two retaining screws (1) from the front of the console frame (see Figure 3)
9. Pull the console rearwards to disengage the two side buttons and the centre pin (2) then lift upwards over the gear selector and remove from the car (see Figure 3)

Important

Whilst carrying out the following operations the operator must note the following warnings to avoid inadvertent deployment of the passive restraint system (air bags)

Caution

Crash sensors are located behind each rear quarter trim panel and must not be disturbed during panel removal. Before starting the removal procedure, refer to 'Precautions-Passive restraint systems and components'. Failure to comply with the instructions could lead to inadvertent deployment of the car air bags and the roll over protection system.

Rep. Gr.69

DANGER!

The seat belt retractor incorporates a pre-tensioner which has a pyrotechnic device, which 'detonates' whenever an air bag is deployed. Refer to Air bag system – Introduction for details

Rep Gr.69

The seat belt retractor is electrically connected to the air bag circuit. Before starting the procedure, refer to 'Precautions – Passive restraint systems and components'. Failure to comply with the instructions could lead to inadvertent deployment of the vehicle air bags. Rep. Gr.69 Remove the air bag fuse and replace it with a dummy fuse (WT 10033). Attach the dummy fuse ribbon to the steering wheel to alert other service technicians that the fuse has been removed.

Rep Gr.69

10. Disconnect both batteries Rep. Gp.27
11. Remove both rear quarter trim panels Rep. Gr 70
12. **Note:** The following shows the removal and wiring modifications performed on the seat belt reel assembly on the left hand side of the vehicle, the same operation has to be performed on the right hand side

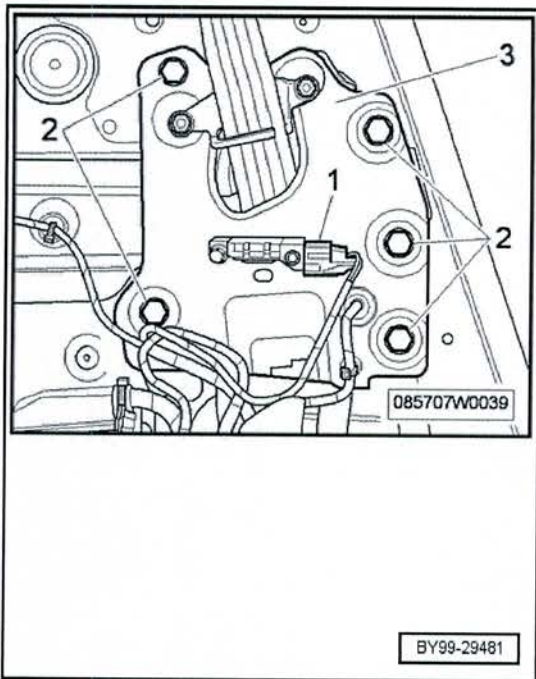

Figure 4

13. Disconnect the main harness from the crash sensor (1). Remove the five screws and washers (2) that secure the retractor mounting plate (3) (see Figure 4)

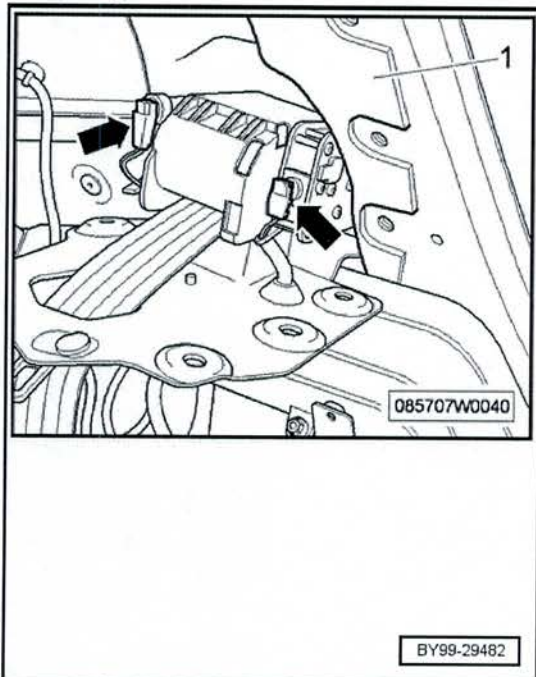

Figure 5

14. Move the retractor plate away from the body taking care not to damage the water shedder (1). If the water shedder is damaged, it must be replaced. (see Figure 5)



Figure 6

15. Disconnect the two electrical connectors (arrows) from the load limiter and pre-tensioner. The pre-tensioner plug housing is yellow and black (1), the load limiter plug housing is all yellow (2). Note: Lift the orange keeper up before attempting to release the connectors from the seat belt assembly (see Figure 6)

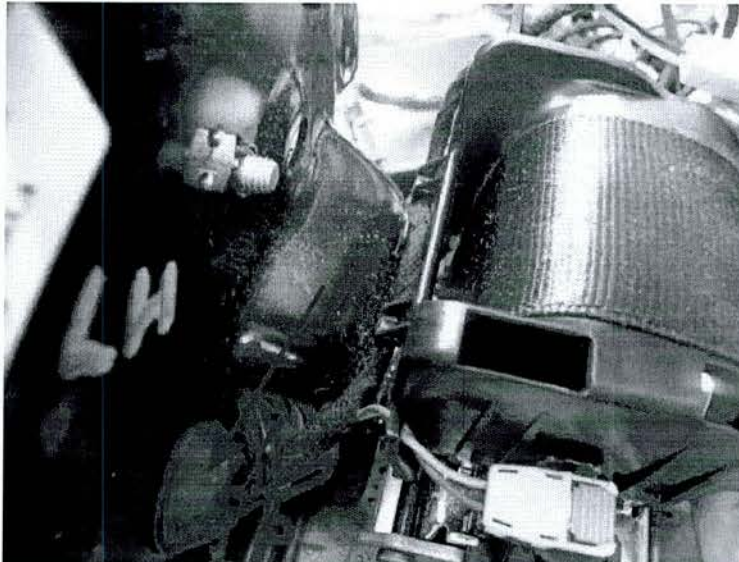

Figure 7

16. Referencing figure 7 cut the plugs off the harness, push out the grommet (arrow) and discard. Tape back the now redundant end of the harness

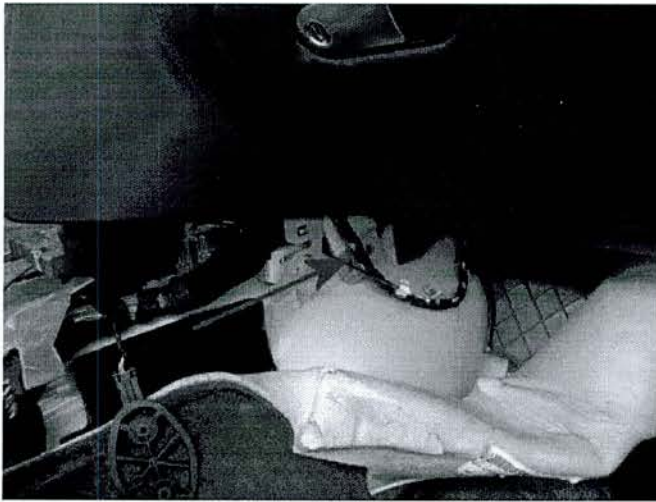

Figure 8

17. To improve access at the air bag control module remove the upper and lower retaining bolts secure the right hand support bracket for the instrument panel (see Figure 8)

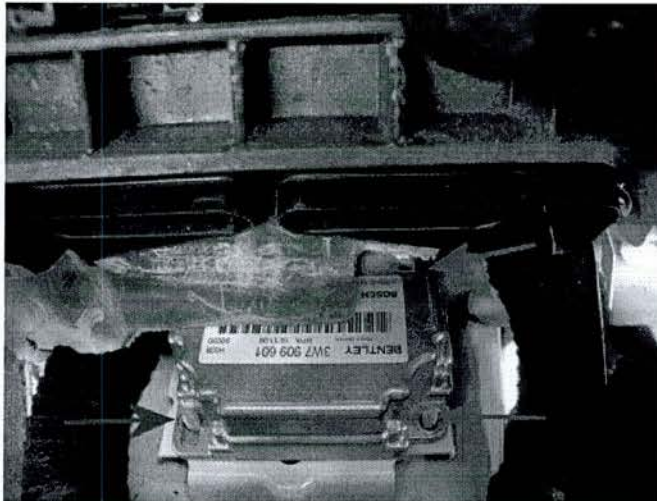

Figure 9

18. Ensure both batteries have been disconnected for a least on minute and are still disconnected before removing three fasteners securing the air bag control module (see Figure 9)



Figure 10

19. Lift the module off the three studs and position through the aperture in the instrument panel enabling access to the electrical connection. To release the connector housing from the control module. 1/ Pull the red locking bar (B) out to unlock. 2/ Rotate the securing cam until the housing is released (see Figure 10). Remove the control module. Note: Do not drop or expose the unit to shock loads

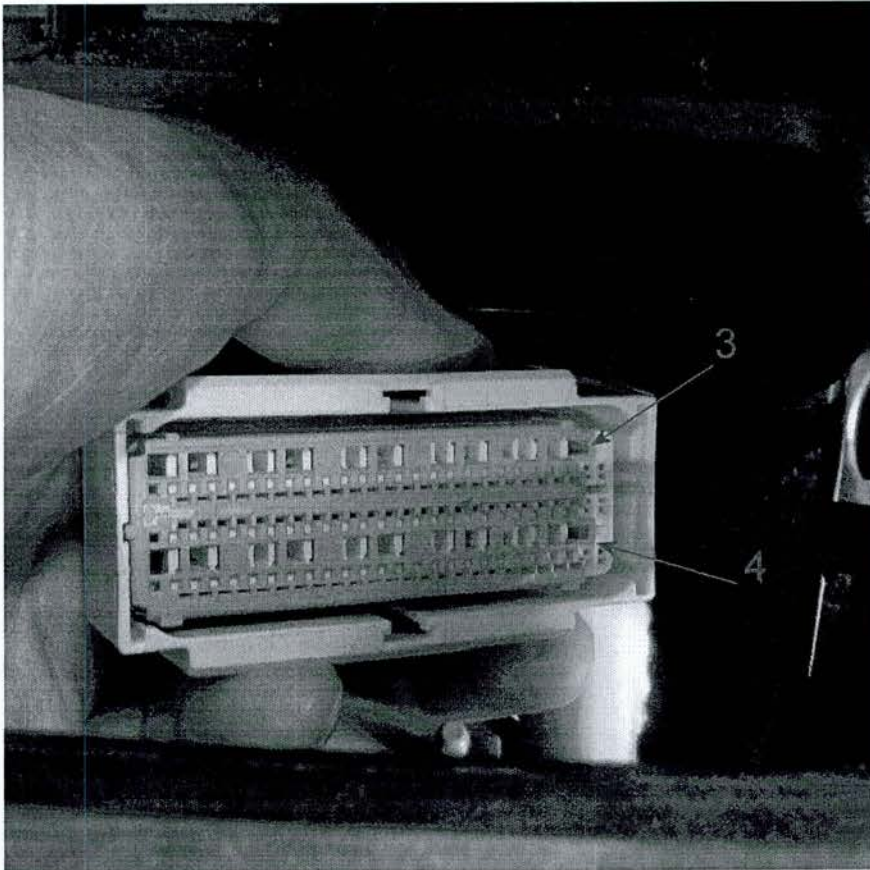

Figure 11

20. Lift and slide the secondary keeper over the two barbs at points 3 and 4 to reveal the terminal lance access ports (see Figure 11)

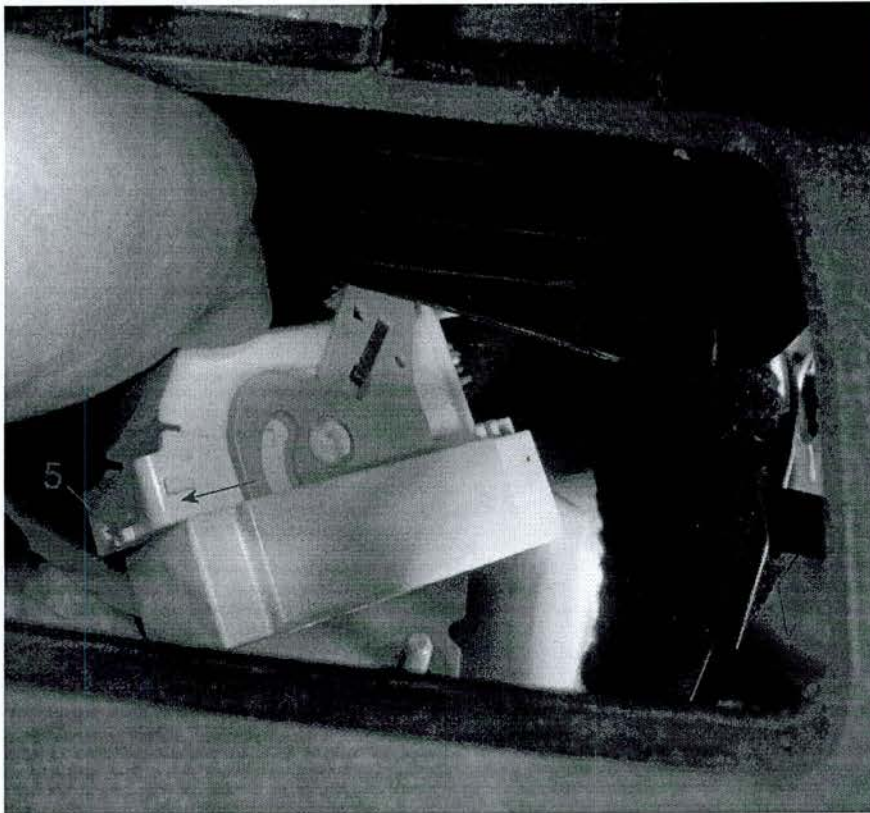

Figure 12

21. Lift and slide the cable cover at the rear of the housing over the two barbs at points 5 then lift the cover off the housing (see Figure 12)

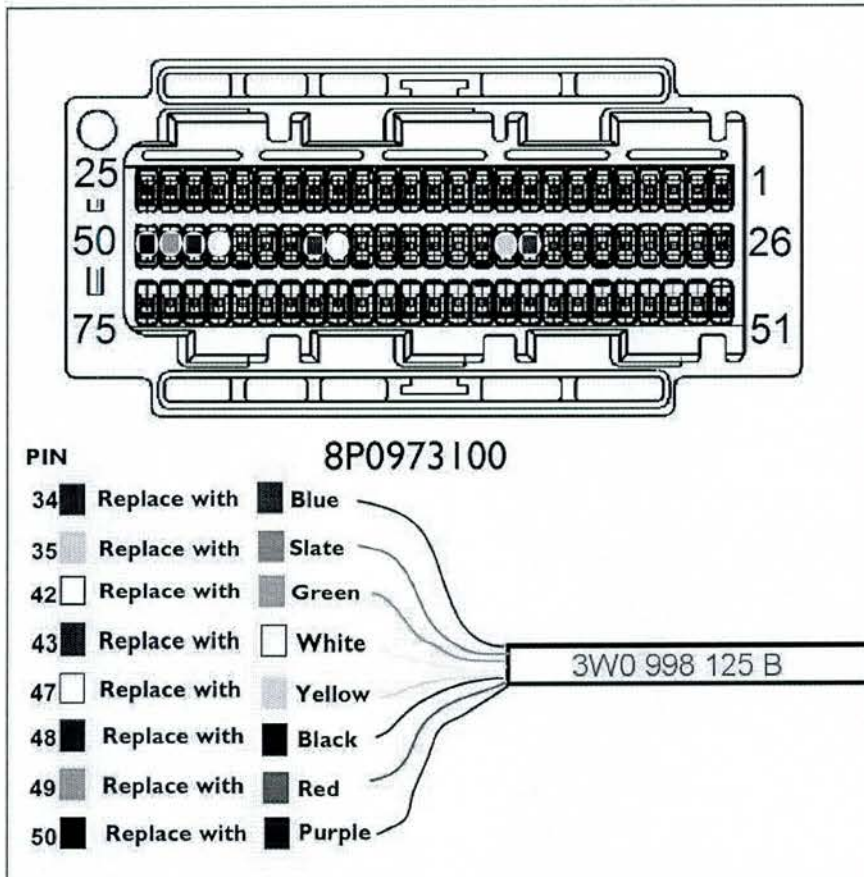

Figure 13

22. Identify the eight wires that have to be removed from the housing (see Figure 13). Note: figure 13 shows the connector face (not cable entry). The left hand list and the plug detail depicts the cable colours originally in the harness. The new cable colours are shown associated with the new harness (part number 3W0 998 125B)

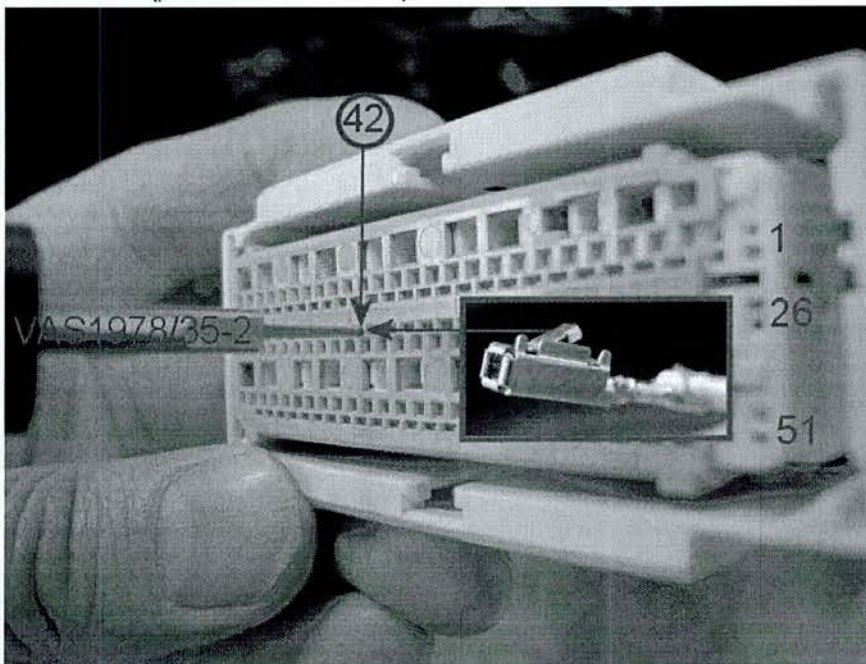

Figure 14

23. Using VAS 1978/35-2 releasing tool from kit ASE 401 578 000 00 extract each of the eight wires in turn.

Note: A sample of vehicles may have the white and brown cables in cavity 47 and 48 transposed this is expected and despite this the new harness cables should be inserted into the cavities as shown in figure 13. This is the yellow in cavity 47 and the black in cavity 48

Note: Each of the eight terminals in the new harness will have a seal incorporated into the crimp this seal may not be present on the original wires in the air bag harness. The absence of this seal in the rest of the housing is not detrimental



Figure 15

24. With the new harness in position fit each of the eight new wires in turn into the correct cavities as detailed in figure 13. Note: the correct orientation of the locking lance when fitting the new terminals into the centre row of cavities in the housing (see Figure 14)
25. Re check that you have correctly populated the air bag control module terminal housing (see Figure 13 and 15)
26. Re engage the secondary keeper, reverse operation 20
27. Remove a section of harness tape to allow the cut point to be staggered then cut off the redundant terminals. Over tape the cut cables before refitting the cable cover onto the rear of the housing, reverse operation 21
28. Re connect the harness to the air bag control module pushing the securing cam down to lock before pushing the red locking bar in, reverse operation 19
29. Position the control module onto the three studs and secure the three fasteners

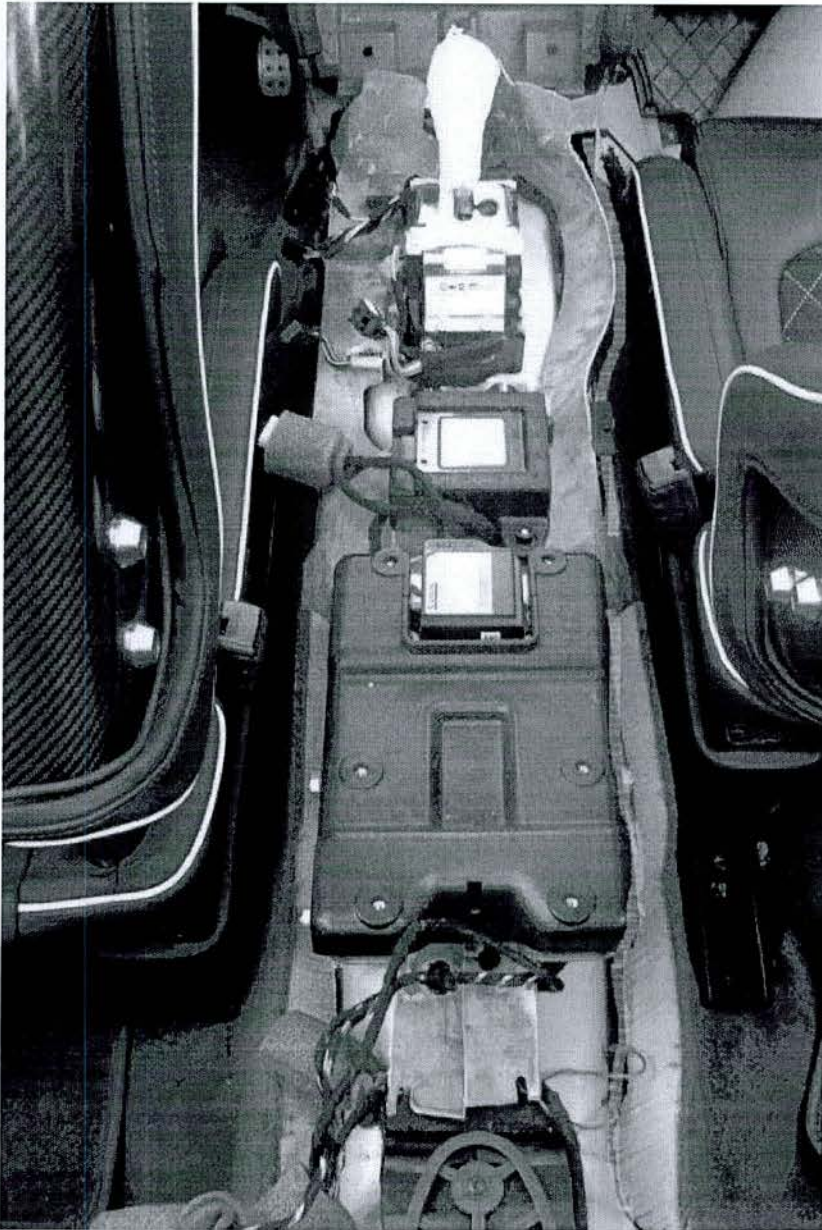

Figure 16

30. Route the new harness down the right hand side following the centre console main harness (see Figure 16)



Figure 17

31. Route each branch from the 'T' point to both seat belt reel assembly's follow the original harness route. (see Figure 17)

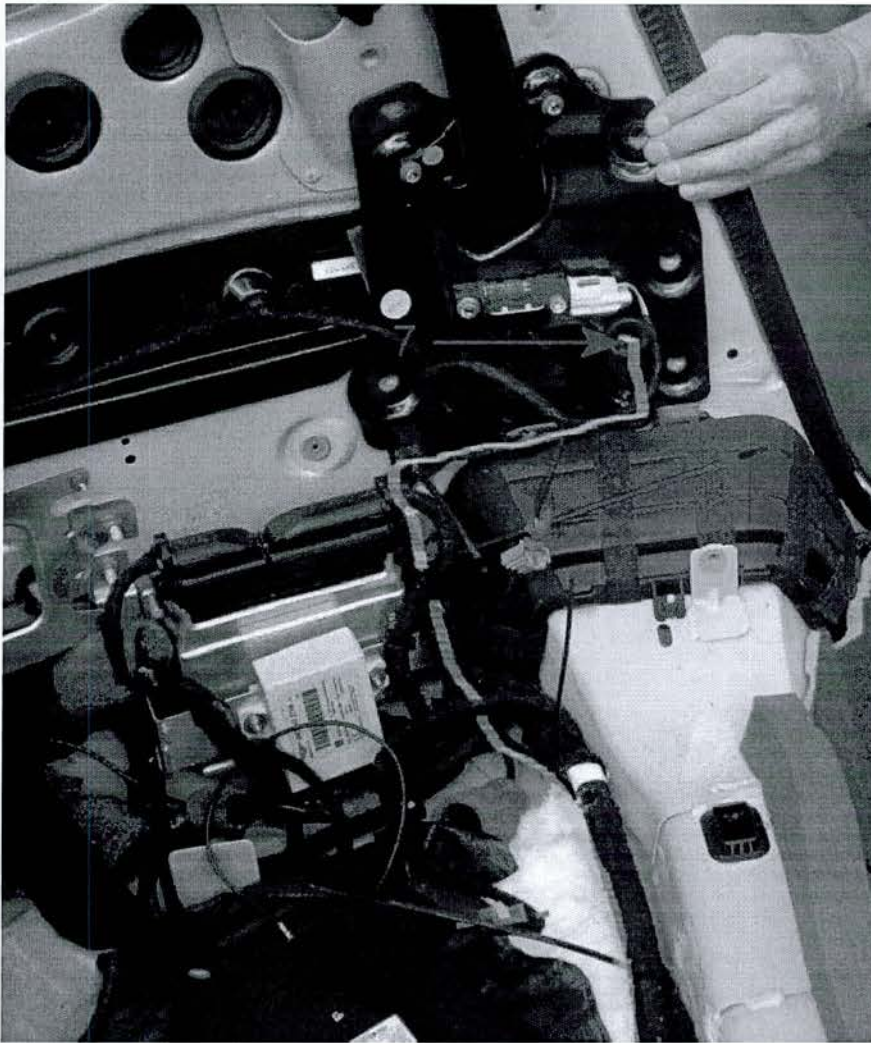

Figure 18



Figure 19

32. Locate the grommet (7) incorporated in the new harness into each retractor plate. To enable correct harness routing on the right hand side remove the fasteners and lift the cable carrier (6), route the new harness under the carrier then refit the carrier. Ensure the harness is not trapped when refitting the carrier. On the left hand side the harness runs over the top of the cable carrier (see Figure 18)
33. Ensure the harness is secure along its entire length, use cable ties where required

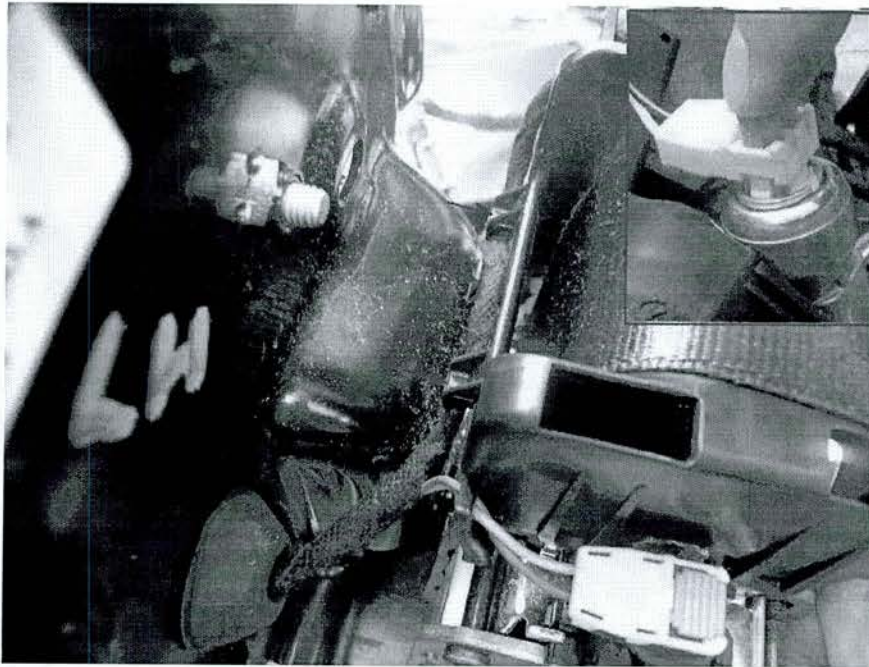

Figure 20

34. With the new harness in position and the grommet (7) engaged in the retractor plate position the harness under, over and finally under the three guides (arrows) before making the connections at each seat belt pre-tensioner and load limiter. To make each connection the respective connector should be positioned over the component before pressing down on the orange keeper this will first engage the main yellow housing into the component before the inhibit is released allowing the orange keeper to engage (see inset Figure 20). Carry out the same operation on the right hand belt assembly

35. Re install all removed parts. Note the following during installation.

- Care must be taken to prevent damage to the water shedder located behind the seat belt retractor plate. If damaged it must be replaced
- Ensure that the seat belt webbing runs correctly through the webbing guides
- Tighten all relevant fixings to the specific torque values
- When refitting the centre console, locate the centre pin (2) first followed by the two side buttons before pushing forward into position
- Use the Bentley diagnostic tool to check for and remove fault codes relevant to this TPI



Figure 21

On completion apply a white paint identification mark adjacent to the OBD connector

Component	Nm	Kgf	Lbf ft
Seat belt retractor plate fasteners	40	4.1	30
Air bag control module	9	0.9	6.6

Warranty

Warranty Type 910 or 110

Labour Operation Code 97 66 19 99

97 66 19 01 (for Supersports version)

Damage Service Number 97 66

Damage Code 02 02

Time 430 time units

Part Number	Description	Quantity
3W0 998 125 B	Overlay harness – seat belt pre tensioner	1