

Plastic Battery Box Cover Retainer Clip

54-274

FLA COE
FLB COE
FLD Conventional
Business Class
FLC 112 Conventional

> Century Class Conventional
Argosy COE
Cargo
> Columbia

> Coronado
> Business Class M2
> Cascadia
108SD/114SD

Freightliner
Service Bulletin

General Information

The plastic battery box cover may become loose, and possibly lost, due do inadequate retention. To improve the retention of a loose or replacement plastic battery box cover, install additional retainers and seals as described in the following work instructions .

Parts

See [Table 1](#) for all vehicles *except* Cascadia 113 BBC.

See [Table 2](#) for Cascadia 113 BBC vehicles.

Battery Box Retainer Parts, All Vehicles Except Cascadia 113 BBC		
Part Number	Part	Quantity
D06-89878-000	Installation Drawing, Retainers, Battery Box	—
A06-89610-003	Coated Retainer, Left Hand	1
A06-89610-004	Coated Retainer, Right Hand	1
06-89611-000	Bulb Seal	2

Table 1, Battery Box Retainer Parts, All Vehicles Except Cascadia 113 BBC

Battery Box Retainer Parts for Cascadia 113 BBC Vehicles		
Part Number	Part	Quantity
D06-89878-001	Installation Drawing, Retainers, Battery Box, Cascadia 113 BBC	—
A06-89610-003	Coated Retainer, Left Hand	1
A06-89610-002	Coated Retainer, Strut	1
06-89611-000	Bulb Seal	2

Table 2, Battery Box Retainer Parts for Cascadia 113 BBC Vehicles

Instructions

1. Park the vehicle, shut down the engine, and apply the brakes. Chock the tires.
 2. Remove the battery box cover.
 3. Install the seals on the left- and right-hand side of the battery box.
 - 3.1 Position the seals at the edge of the battery box front plate flange, with the bulb-side of each seal oriented to the outside of the box. See [Fig. 1](#) for all vehicles *except* Cascadia 113 BBC vehicles. See [Fig. 2](#) for Cascadia 113 BBC vehicles.
 - 3.2 Press the seals into the battery box until they fit securely.
 4. Loosen the two upper bolts that secure the battery box to the frame rail.
- NOTE: The bolt, the nut, and the two washers will be used to install the retainers.
5. Position the retainer between the washer and bolt head. See [Fig. 1](#) and [Fig. 2](#).
 - 5.1 Feed the bolt through the retainer, then install one of the washers.
 - 5.2 Install the nut, and tighten 136 lbf-ft (184 N·m).

Freightliner Service Bulletin

FLA COE
FLB COE
FLD Conventional
Business Class
FLC 112 Conventional

> Century Class Conventional
Argosy COE
Cargo
> Columbia

> Coronado
> Business Class M2
> Cascadia
108SD/114SD

5.3 Repeat this procedure for the other retainer.

6. Install the batter box lid so it fits securely over the seals. See **Fig. 3**.

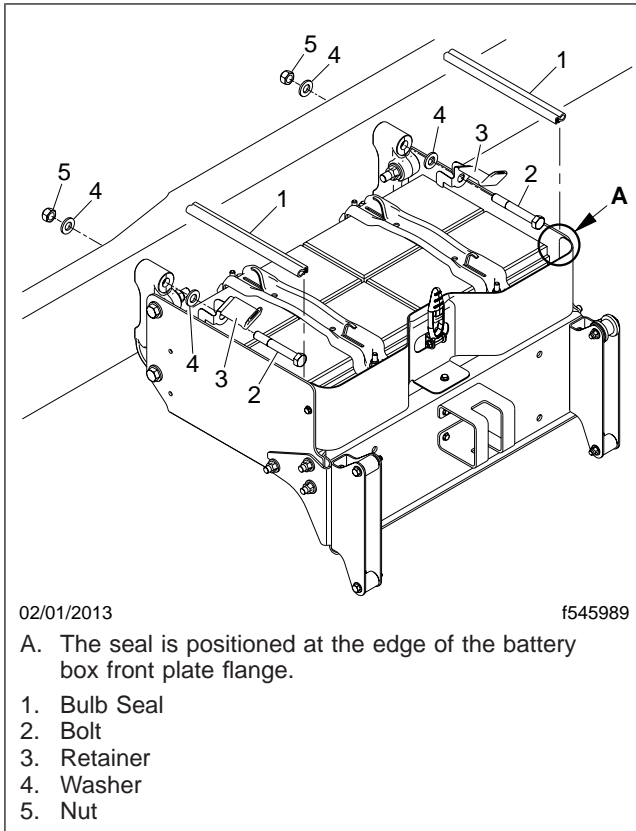

Fig. 1, Battery Box Retainer Installation, All Vehicles Except Cascadia 113 BBC

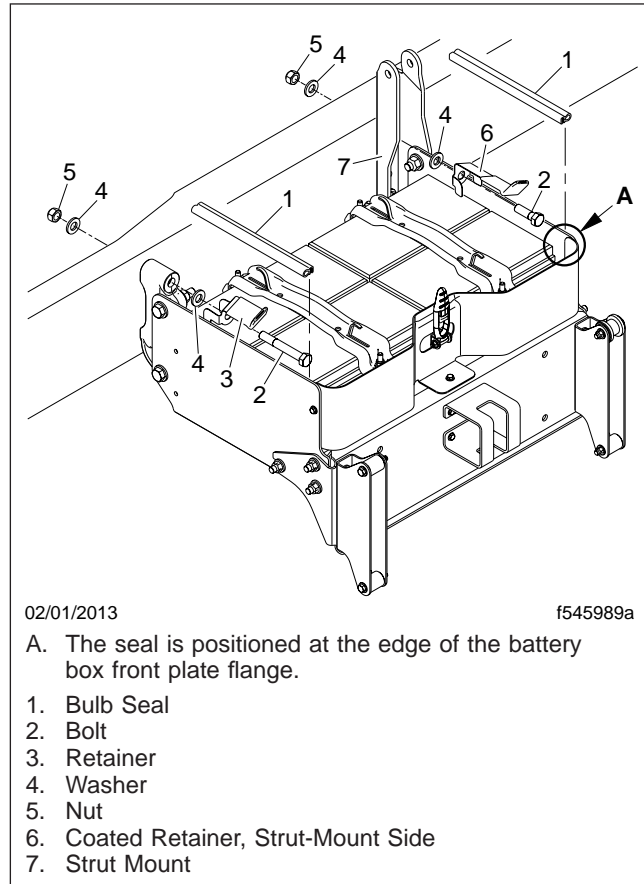

Fig. 2, Battery Box Retainer Installation, Cascadia 113 BBC Vehicles

7. Position the battery box cover so it fits securely under the retainers.

Warranty

This procedure is warrantable only if the described condition exists and the repair is performed within the applicable base or extended coverage warranty period. If a failure is not found, this procedure is considered preventive and warranty does not apply.

Normal warranty applies. See **Table 3** for QuickClaim damage code and labor allowance information. Refer to this service bulletin by number at the beginning of the claim comments. See **Table 4** for OWL VMRS codes and labor allowance information. Enter this service bulletin number in the *Service Bulletin #* field.

Plastic Battery Box Cover Retainer Clip

54-274

FLA COE
 FLB COE
 FLD Conventional
 Business Class
 FLC 112 Conventional

> Century Class Conventional
 Argosy COE
 Cargo
 > Columbia

> Coronado
 > Business Class M2
 > Cascadia
 108SD/114SD

**Freightliner
 Service Bulletin**

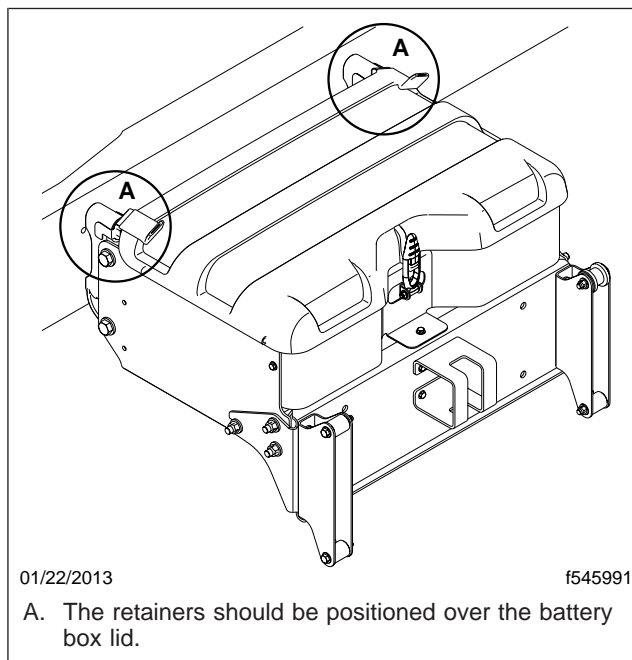

Fig. 3, Battery Box Retainer Installation

QuickClaim Damage Code and Labor Allowance			
Damage Code	SRT Code	Description	Time: Hours
289-000A01950	290-5010A	Retainer, Battery Box Cover, Install	0.3

Table 3, QuickClaim Damage Code and Labor Allowance

OWL VMRS Codes and Labor Allowance					
Primary Failed Part	Component Code	Cause Code	SRT Code	Description	Time: Hours
Battery Box Cover	014-005-006	30	290-5010A	Retainer, Battery Box Cover, Install	0.3

Table 4, OWL VMRS Codes and Labor Allowance