



Date	Group	No.	Release	Page
11.13	512	002	01	1(17)

SB-10054105-4632

Thermal Overload, Air Disc Brakes
CHU, CXU, GU, LEU, MRU, TD

FSB 512-002, Thermal Overload, Air Disc Brakes

(November 2013)

It has been reported in the field that the Bendix air disc brake may exhibit a thermal overload condition. Thermal overload is simply an over adjustment of the normal pad wear compensation that maintains the running clearance between the brake pad and rotor. Thermal overload reduces the running clearance between the pad and rotor below a desired level. This over adjustment does not come on suddenly, but rather slowly over time, until the running clearance goes to zero and the pads are in contact with the rotor. Under this condition the pads swell and may drag until the high temperature (accelerated) wear removes enough pad material to reestablish running clearance. The main causal issue is high frequency or magnitude of axle vibration and why it is typically only seen at one wheel end.

There have been very limited occurrences of thermal overload across varying applications and vehicle configurations. However, in the event that any of the above issues are found, or any thermal overload is suspected, immediately go to the on-line document library at www.bendix.com for free downloads of Service Data Sheets (SD-23-7541). BW7514b will provide specific instructions regarding how to diagnose a potential thermal overload occurrence. You can also contact the Bendix Technical Help Line: 1-800-AIR-BRAKE, (1-800-247-2725) and select option 2, then option 1, Mon.- Fri., 8 a.m. - 6 p.m. EST. for information on how to remedy these issues.

Bendix Document Number and Description

- BW7514 – Thermal Overload Checklist
- SD-23-7541 – AIR DISC BRAKE ADB22X AND ADB22X-V

Bendix Contact Info

- Website: www.bendix.com
- Tech team phone number: 1-800-AIR-BRAKE
- Tech team e-mail: TechTeam@Bendix.com

Part Numbers

- 85136663 — Disc Brake Caliper Assembly LHS
- 85136662 — Disc Brake Caliper Assembly RHS
- 85136940 — Brake Shoes

Caliper Fasteners

		Highway	Refuse
Steer Axle	Washer	994875	994875
	Bolt	992475	992935
Drive Axle	Washer	994875	994875
	Bolt	992475	993339 (Ridewell Quantity 5 and HN Quantity 6)
			993337 (Ridewell Quantity 1)

Inspection Procedure

Inspect Vehicle (Thermal Overload Event)

- 1 Secure the vehicle for service by parking it on a level surface, applying the parking brake, blocking the wheels, and placing the transmission in neutral or park.
- 2 Disconnect all cables from the negative (ground) battery terminals to prevent personal injury from electrical shock and prevent damage to electrical components.
- 3 Follow safe lifting guidelines, lift and support both the frame and the axle housing.



DANGER

Failure to properly support the front of the axle housing may result in the axle rolling forward, causing serious injury or death.

- 4 Remove the wheel/tire assemblies.
- 5 Release the parking brake.
- 6 Retrieve instructions for inspection by accessing Bendix website at bendix.com.
- 7 Perform a search for the words "Thermal Overload".
- 8 Click "*more*" on the *Bendix Commercial Vehicle Systems, BW7514 THERMAL OVERLOAD CHECKLIST Download*.
- 9 Download the latest *BW7514 THERMAL OVERLOAD CHECKLIST*.
- 10 Perform steps in the checklist.
- 11 Replace as needed.

Brake Pad Replacement

- 1 Chock the wheels.
- 2 Lift and support the axle on jack stands.
- 3 Release the parking brakes.
- 4 Remove the wheel/tire assembly(s) from the wheel end(s) in question.
- 5 Back off the brake adjuster.
- 6 Remove the brake pad retainer, pin and clip.

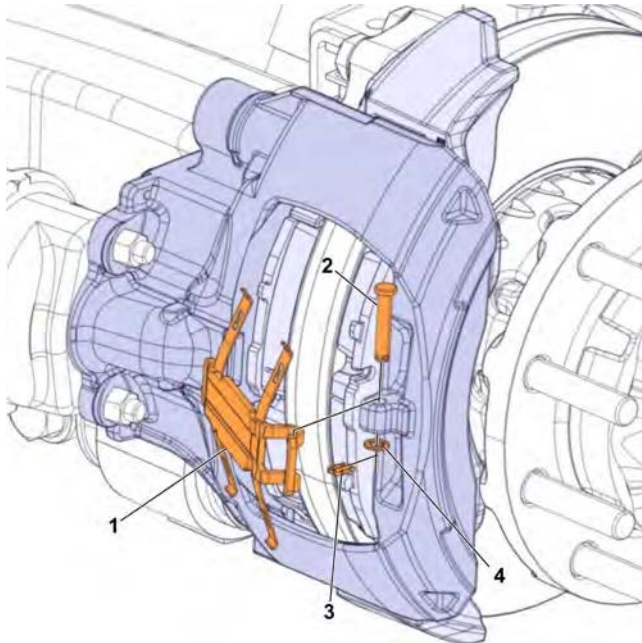

W5084508

- 1 Retainer
- 2 Pin
- 3 Clip
- 4 Washer

7 Remove the brake pads.

Note: Ensure the rest of the brake assembly is operational and within serviceable limits.

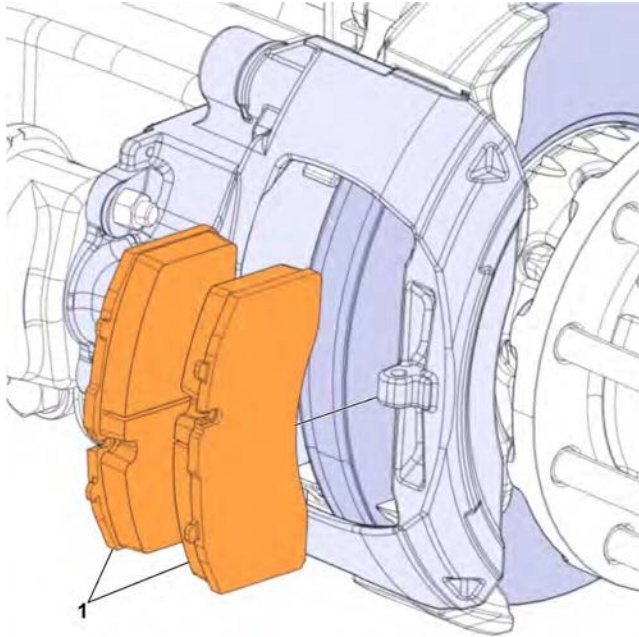

W5084510

1 Pad removal

- 8 If wear sensors are used, ensure they are serviceable or replace as needed. The adjuster may need to be turned counter-clockwise to open up enough room between the caliper and rotor to install the pads. Clean the brake pad contact area on caliper. Install new brake pads.

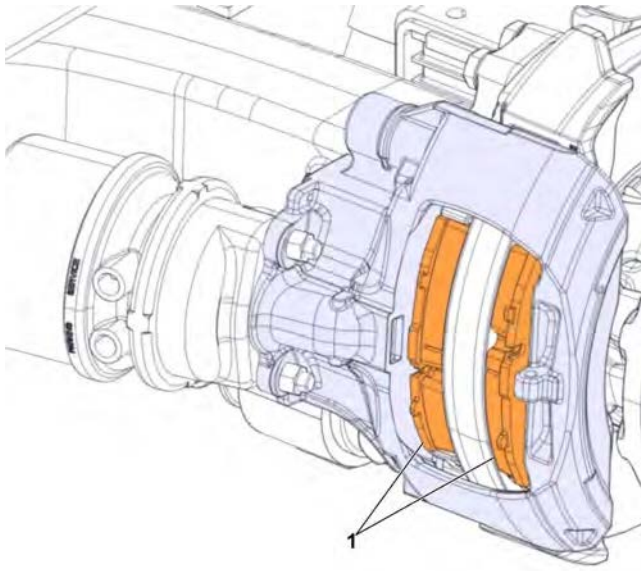

W5084526

1 Pads installed

9 Secure pads with retainer, pin, washer and clip.

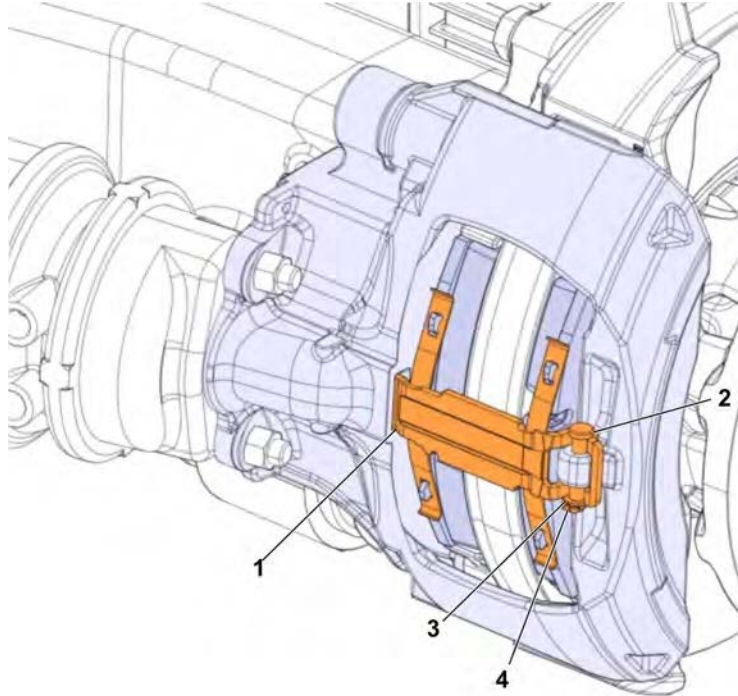

W5084527

- 1 Retainer
- 2 Pin
- 3 Clip
- 4 Washer

10 Adjust the brake pad clearance by turning the adjuster screw until the clearance between the tappets and pads is between 0.5 mm (0.020 in.) and 1.0 mm (0.040 in.).

Note: The caliper should be pushed inboard on its guide pins during this check.

11 Repeat the above steps for the other wheel end of the same axle.

12 Install wheel/tire assembly(s). Torque wheel nuts to 610 Nm (450 ft-lb).

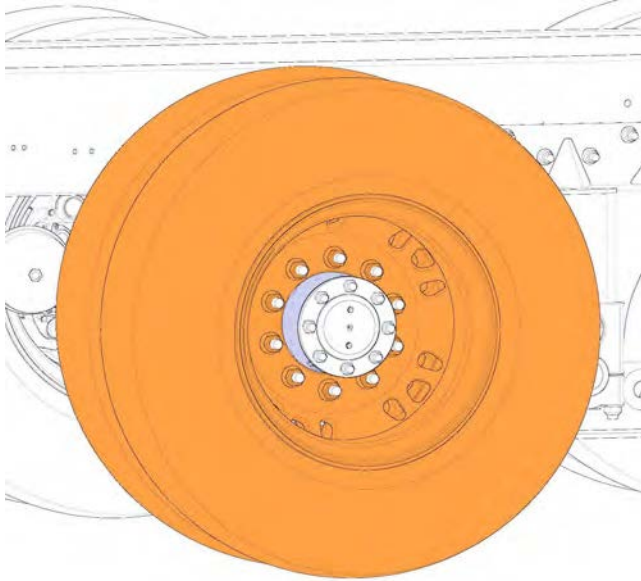

W5084816

13 Apply the parking brake.

14 Lift the axle, remove the jack stands and chocks. Lower vehicle.

Caliper Removal

- 1 Chock the wheels.
- 2 Lift and support the axle on jack stands.
- 3 Release the parking brakes.
- 4 Remove the wheel/tire assembly(s) from the wheel end(s) in question.

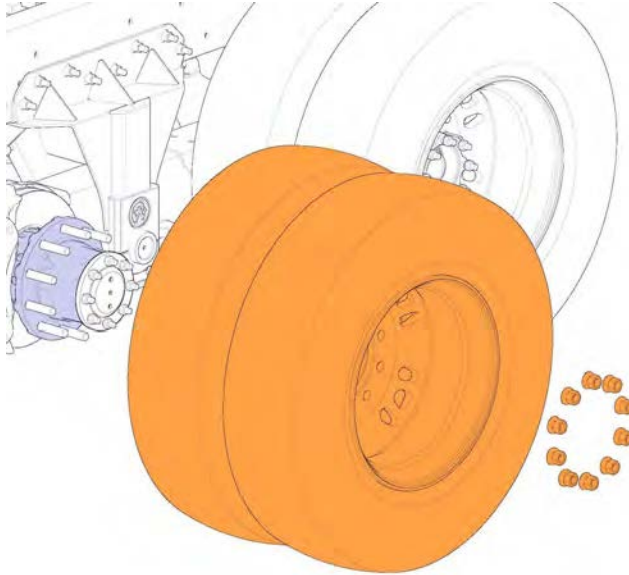

W5084810

- 5 Back off the brake adjuster.
- 6 Remove the brake pad retainer, pin and clip.

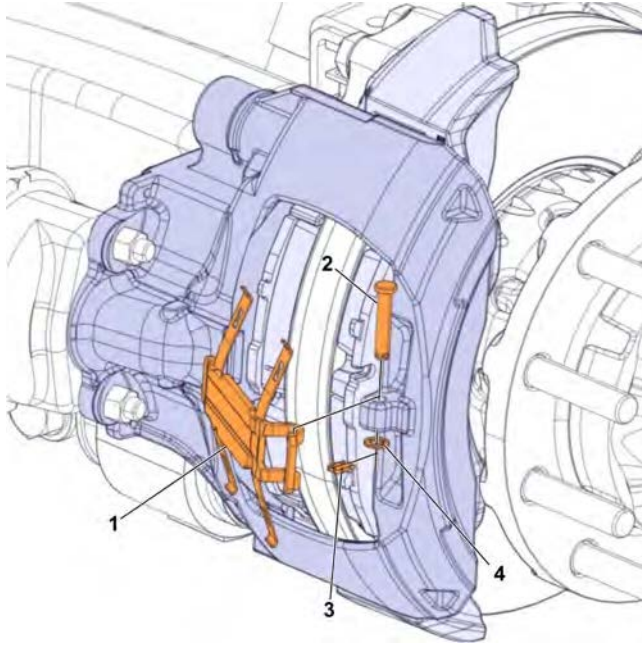

W5084508

- 1 Retainer
- 2 Pin
- 3 Clip
- 4 Washer

- 7 Remove the brake pads.

Note: Ensure the rest of the brake assembly is operational and within serviceable limits.

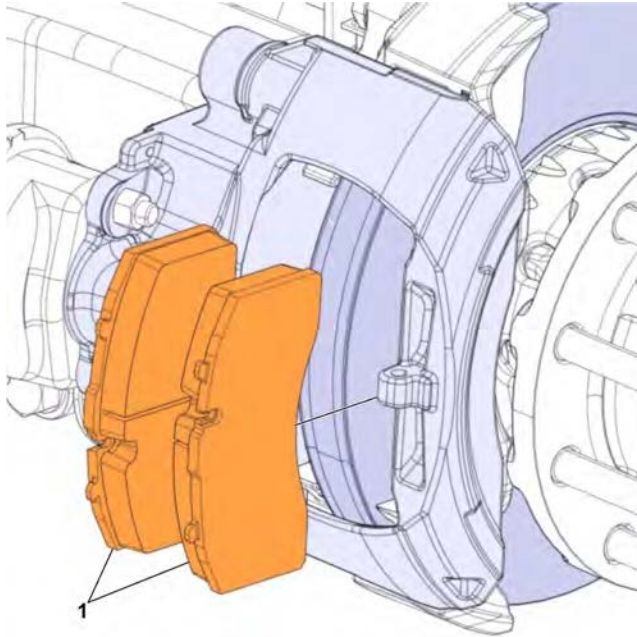

W5084510

- 1 Pad removal
- 8 Release parking brakes and cage brake chamber (if applicable).
- 9 Remove the brake hose.

10 Remove the actuator assembly - service brake chamber or park brake chamber.

Note: Brake chamber mounting hardware can be reused.

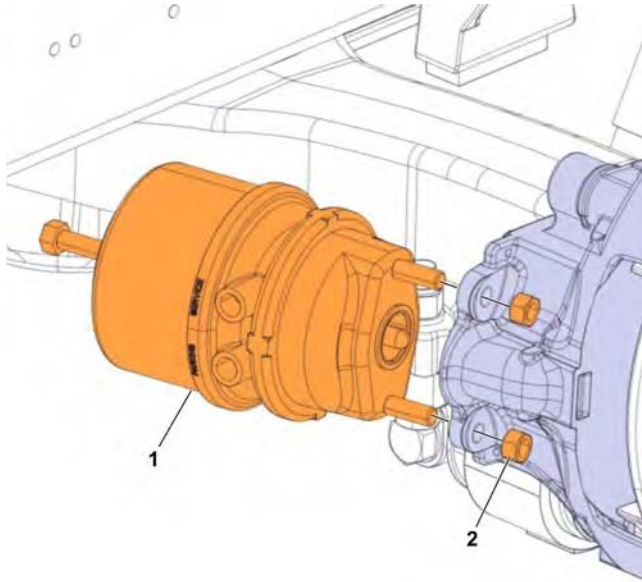

W5084511

1 Actuator Assembly (Park Brake Chamber)

2 Fasteners

11 Remove the outer boot clips or cap.



WARNING

Never insert fingers between caliper and carrier. Hold the exterior of caliper only, or serious personal injury may result.

12 Remove the caliper bolts and discard. **Use new caliper mounting hardware.**

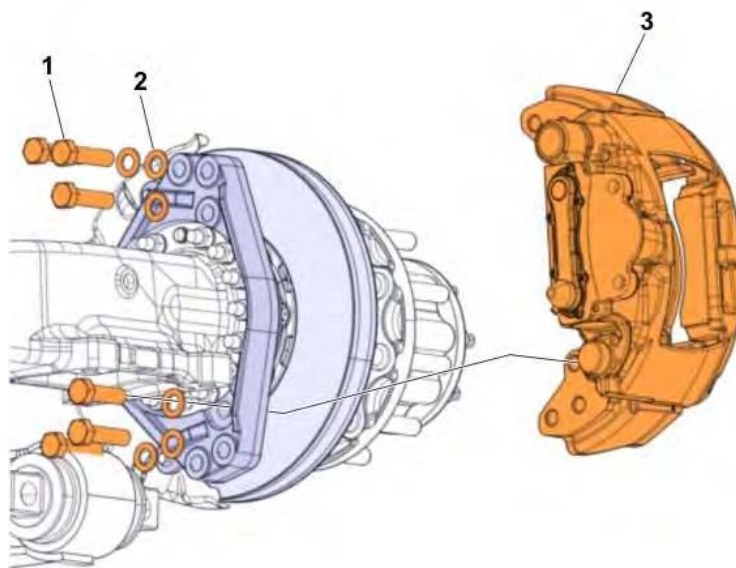

W4084963

- 1 Bolts
- 2 Washers
- 3 Caliper

13 Remove lower fasteners on suspension (if applicable) to access caliper bolts.

14 Remove upper fasteners (if applicable).

15 Remove bracket (if applicable).

Caliper Installation

- 1 Install caliper to carrier with **new** hardware and tighten M20 bolts to 508 Nm (375 ft-lb) for **Highway** brake or 271 Nm + 60 degrees (200 ft-lb + 60 degrees) for **Refuse** brake.

Note: Check caliper hardware part numbers to ensure correct installation of new caliper (refer to table on page 2).

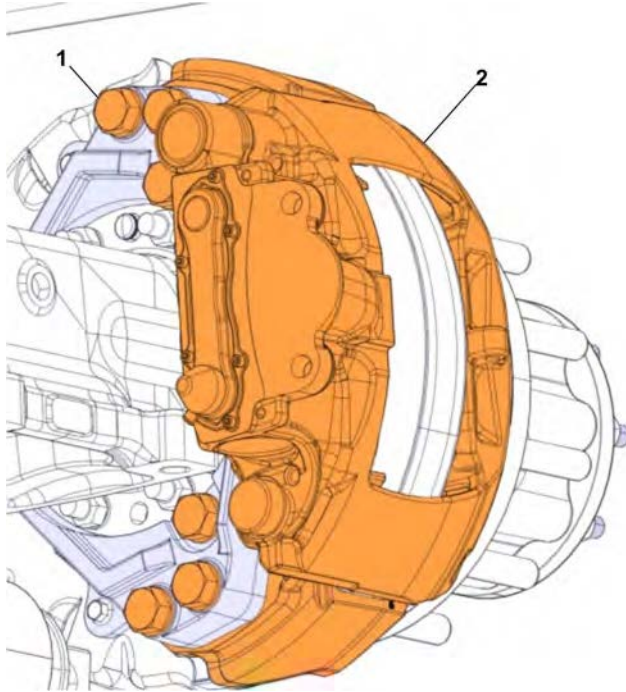

W5084524

- 1 Fastener
- 2 Caliper

- 2 Check caliper after mounting to carrier: Ensure caliper slides easily on carrier and check inner boot position on caliper bolt sleeves.
- 3 Install rubber boots and clips.
Note: Replace rubber boots and clips if necessary.
- 4 If wear sensors are used, ensure they are serviceable or replace as needed. The adjuster may need to be turned counter-clockwise to open up enough room between the caliper and rotor to install the pads. Clean the brake pad contact area on caliper.
- 5 Install new brake pads and secure retainer, pin, washer and clip. Torque to 27 ±3 Nm (20 ±2 ft-lb).

- 6 Install the actuator assembly - service brake chamber or park brake chamber. Torque to 180 ± 30 Nm (133 ± 22 ft-lb).

Note: Brake chamber mounting hardware can be reused.

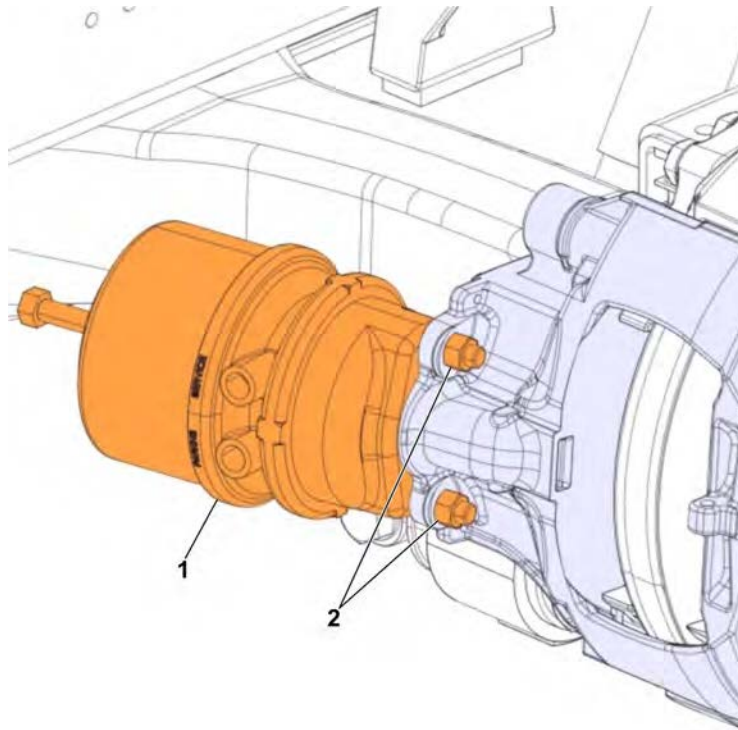

W5084525

- 1 Actuator Assembly (Park Brake Chamber)
 - 2 Fastener
- 7 If spring brake chamber was installed, un-cage park brake chamber at this time.
 - 8 Install brake hose.
 - 9 Adjust the brake pad clearance by turning the adjuster screw until the clearance between the tappets and pads is between 0.5 mm (0.020 in.) and 1.0 mm (0.040 in.).
- Note:** The caliper should be pushed inboard on its guide pins during this check.

10 Install wheel/tire assembly(s). Torque wheel nuts to 610 Nm (450 ft-lb).

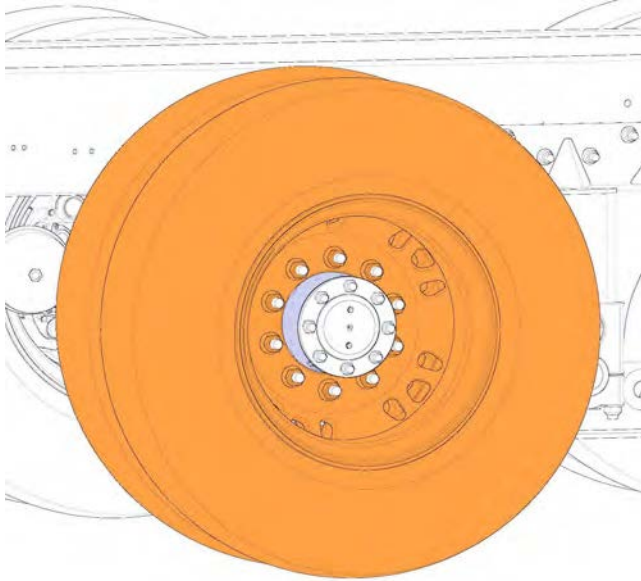

W5084816

11 Apply the parking brake.

12 Lift the axle, remove the jack stands and chocks. Lower vehicle.

Rotor Inspection

Refer to Bendix Service Data Sheet SD-23-7541 for rotor inspection.

- Use wire brush to thoroughly remove all orange discoloration from all rotor surfaces to prevent future misdiagnosis of the wheel end.
- If thorough inspection indicates rotor must be replaced, replace per instructions in Bendix Service Data Sheet SD-23-7541.

Note: If rotor replacement is required, use part number 21538404.