

This bulletin replaces PV729-FSB356-003 (USA41001) dated 2.2010.

Date 10.13 Group **356** No. **003** Release Page 1(5)

Fog Lamp Moisture Intrusion
 VNL Version2

FSB 356-003, Fog Lamp Moisture Intrusion

(October 2013)

It was determined that the use of pneumatic or high torque electric tools caused the captive nuts moulded into the fog lamp housing to spin and crack the housing. To prevent future failures, a new fog lamp installation procedure has been created. Should a fog lamp assembly require replacement, the new installation procedure must be used for the repair.

Procedure

You must read and understand the precautions and guidelines in Service Information, group 3, "General Safety Practices, Electrical" before performing this procedure. If you are not properly trained and certified in this procedure, ask your supervisor for training before you perform it.

- 1 Open the hood

Service personnel: Please circulate, read and initial

Service Manager	Warranty Administrator	Workshop Foreman	Service Technicians						

- 2 Using hand tool only, remove the three (3) mounting bolts.

Note: Do not use pneumatic or high torque electric tools this may cause the captive nuts to spin and crack the fog lamp housing.

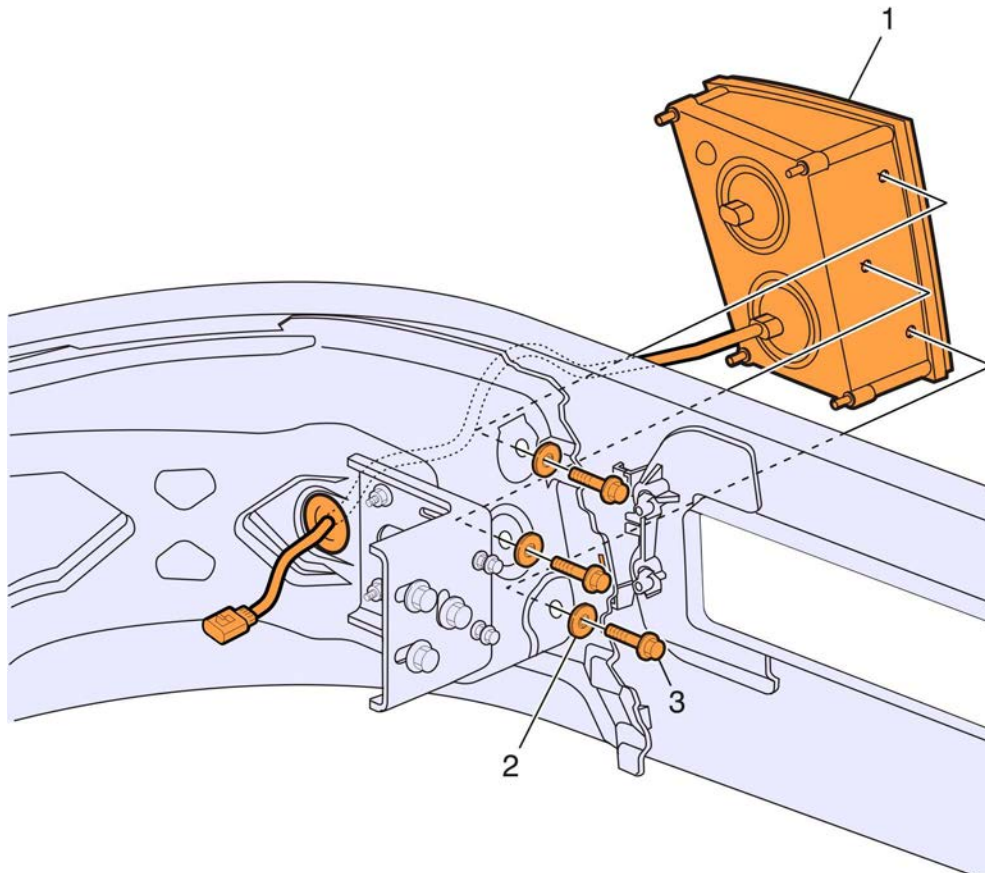

W3047653

- 1 Fog Lamp
- 2 Washer
- 3 Bolt

- 4 Remove the fog lamp assembly from the bumper
- 5 Insert the fog lamp assembly into the bumper

- 6 Install the bolt finger tight, then using only hand tools torque tighten to 7 Nm (5 ft-lb).

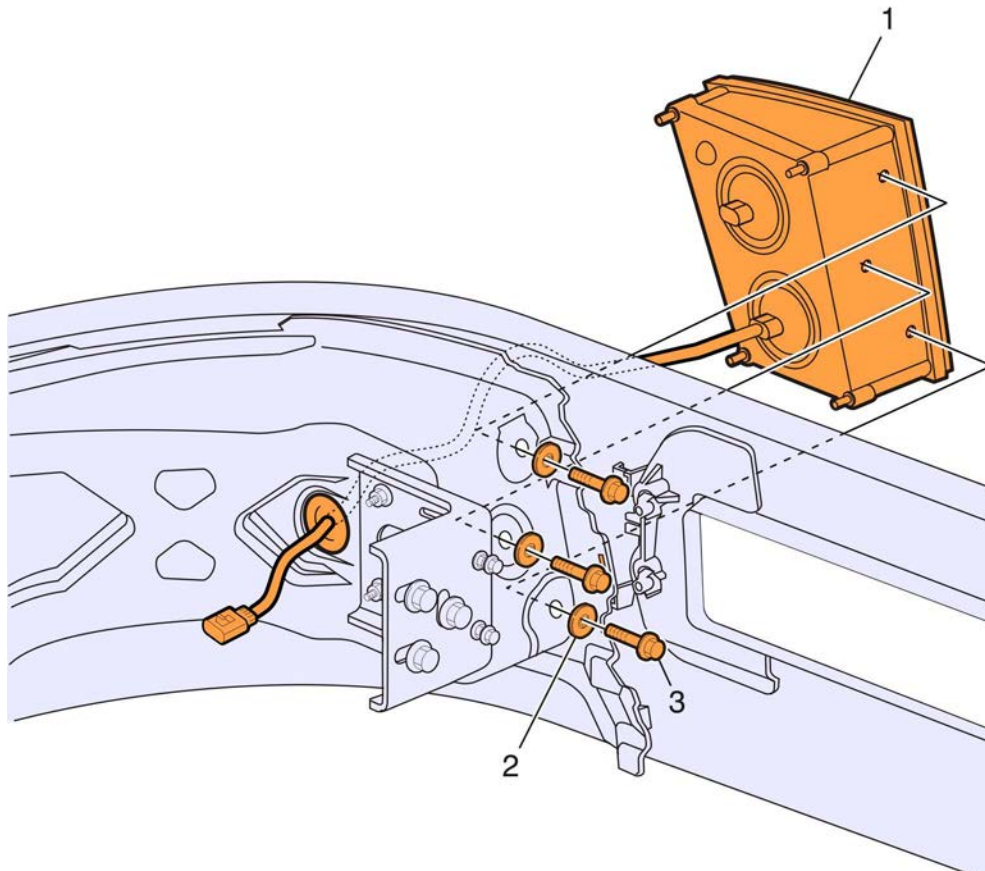

W3047653

- 1 Fog Lamp
- 2 Washer
- 3 Bolt

Volvo Trucks North America engages in a continuous program of testing and evaluating to provide the best possible product. Volvo Trucks North America, however, is not committed to, or liable for updating existing chassis.