

6F50/6F55 TRANSMISSION—SLIP/NEUTRAL OUT—
5TH GEAR START FROM STOP—BACKUP CAMERA
ON IN DRIVE—BUILT 3/13/2009-6/30/2010

TSB 13-5-27

FORD:

2009-2011 Taurus, Edge, Flex

LINCOLN:

2009-2011 MKS, MKX
2010-2011 MKT

This article supersedes TSB 13-4-2 to update Service Procedure

ISSUE

Some 2009-2011 Edge, Taurus, Flex, MKS, MKX and 2010-2011 MKT vehicles equipped with a 6F50 or 6F55 transmissions and built on 3/13/2009 and through 6/30/2010 may intermittently exhibit one or more of the following concerns; transmission slipping or neutral-out, 5th gear start from stop, backup camera on in Drive, or speed control dropping out or inoperative. This may be due to high resistance in the digital transmission range (TR) sensor.

ACTION

Follow the Service Procedure steps to correct the concern.

SERVICE PROCEDURE

Check the TR sensor circuit resistance.

1. With brakes applied, engine off, key on, move the shifter to low gear (L or M) position.
2. Turn key off.
3. Disconnect connector C168 from the transmission.
4. Measure the resistance between the transmission connector pins:
 - 8 and 4
 - 8 and 5
 - 8 and 6
 - 8 and 7
 - a. The top row of the transmission's pins are numbered 1-10 from left to right. (Figure 1)

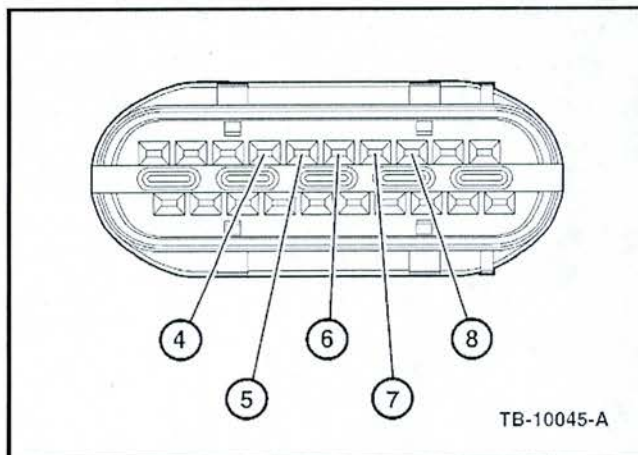
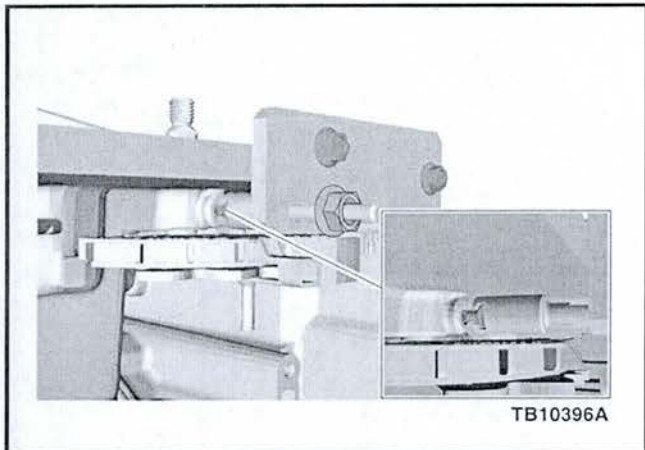

Figure 1 - Article 13-5-27

- b. If any of the four measurements are above 5 Ohms, proceed to Step 5.
- c. If all measurements are within specification, this article does not apply. Refer to the appropriate Workshop Manual (WSM) Section for diagnosis and repair.
5. Replace the TR sensor. Refer to the WSM, Section 307-01.
 - a. Use only essential special service tool (ESST) 307-696 to remove the retaining pin that holds the TR sensor in the transmission case.
 - b. Attach ESST 307-696 to the transmission case with two (2) pan bolts.
 - c. Slide the cylinder over the head of the retaining pin and tighten the nut on the threaded shaft to pull the cylinder up and retaining pin out of the transmission case. (Figure 2)

NOTE: The information in Technical Service Bulletins is intended for use by trained, professional technicians with the knowledge, tools, and equipment to do the job properly and safely. It informs these technicians of conditions that may occur on some vehicles, or provides information that could assist in proper vehicle service. The procedures should not be performed by "do-it-yourselfers". Do not assume that a condition described affects your car or truck. Contact a Ford or Lincoln dealership to determine whether the Bulletin applies to your vehicle. Warranty Policy and Extended Service Plan documentation determine Warranty and/or Extended Service Plan coverage unless stated otherwise in the TSB article. The information in this Technical Service Bulletin (TSB) was current at the time of printing. Ford Motor Company reserves the right to supersede this information with updates. The most recent information is available through Ford Motor Company's on-line technical resources.

TSB 13-5-27 (Continued)



TB10396A

Figure 2 - Article 13-5-27

- d. Do not allow the park pawl actuator rod to become disengaged from the park pawl and the abutment. Keep the end of the park pawl actuator rod behind the machined valve body mating surface of the transaxle case. If the park pawl actuator rod becomes disengaged from the park pawl and the abutment, transaxle removal and disassembly is required to install the actuator rod. (Figure 3)

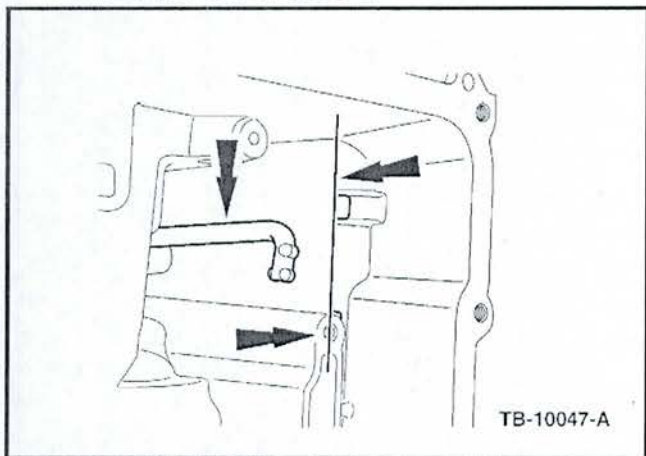

TB-10047-A

Figure 3 - Article 13-5-27

PART NUMBER	PART NAME
9E9Z-7H557-B	TR Sensor
7T4Z-7B210-A	Retaining Pin

WARRANTY STATUS: Eligible Under Provisions Of New Vehicle Limited Warranty Coverage And Emissions Warranty Coverage
 Warranty/ESP coverage limits/policies/prior approvals are not altered by a TSB.
 Warranty/ESP coverage limits are determined by the identified causal part and verified using the OASIS part coverage tool.

OPERATION	DESCRIPTION	TIME
130527A	2009-2011 Edge, Flex, MKX, MKS, Taurus and 2010-2011 MKT: Replace The TR Sensor Includes Time To Perform The Diagnosis In The Service Procedure	2.5 Hrs.

DEALER CODING

BASIC PART NO.
7H557

CONDITION
CODE
42