

SB-10052599-7956

TECHNICAL BULLETIN
UPS4812-6bNAS2
31 MAY 2013



© Jaguar Land Rover North America, LLC

NOTE: The information in Technical Bulletins is intended for use by trained, professional Technicians with the knowledge, tools, and equipment required to do the job properly and safely. It informs these Technicians of conditions that may occur on some vehicles, or provides information that could assist in proper vehicle service. The procedures should not be performed by 'do-it-yourselfers'. If you are not a Retailer, do not assume that a condition described affects your vehicle. Contact an authorized Jaguar service facility to determine whether this bulletin applies to a specific vehicle.

Changes are highlighted in gray

SECTION: 502-00

Update Prior to Sale: Front Sub Frame Bolts Incorrectly Torqued

AFFECTED VEHICLE RANGE:

XF (X250)
Model Year: 2012-2013
VIN: S60251-S62610

MARKETS:

NAS

CONDITION SUMMARY:

Situation: A concern has been identified with a limited number of 2012 model year XF vehicles where the front subframe rear bolts have the incorrect torque applied.

Action: Retailers are required to HOLD all affected vehicles in the above VIN range that are in their control and refrain from releasing the vehicles for new or used vehicle sale pending completion of the rework action detailed in this Technical Bulletin. This rework action should be performed after completing the Pre-Delivery Inspection (PDI) process.

PARTS:

The parts below should be ordered through Jaguar Parts Operations in the normal manner.

Description	Part No.	Qty.	Expected % of vehicles requiring this part*
Bolt	C2P7447	2	100

* - when ordering parts, please order the expected percentage failure rate of parts identified only

SPECIAL TOOLS:

Refer to Workshop Manual / Service Instruction for any required special tools

WARRANTY:

NOTE: Always check DDW to verify that the vehicle is affected by this program prior to undertaking any repairs. Repair procedures are under constant review, and therefore times are subject to change; those quoted here must be taken as guidance only. Refer to Repair Times Searcher (RTS) on TOPIX to obtain the latest repair time.

Warranty claims must be submitted quoting Program Code 'K154' together with the relevant Option Code from the table. The SRO and part information listed have been included for information only. The Option Code(s) that allows for the drive in / drive out allowance can only be claimed if the vehicle is brought back into the workshop for this action alone to be undertaken.

This program is valid for a limited time only. Warranty claims with a repair date prior to the 17 October 2013 closure date must be submitted for payment within 30 calendar days of completion of the repair.

Program Code	Option Code	Description	SRO	Time	Part No.	Qty. / Value
K154	B	Install new front subframe rear bolts and re-torque front bolts	10.10.99	0.20	C2P7447	2
K154	C	Install new front subframe rear bolts and re-torque front bolts Drive in/drive out	10.10.99 10.10.10	0.20 0.10	C2P7447 -	2 -
K154	D	Install new front subframe rear bolts and re-torque front bolts - 5.0L Supercharged Only	05.10.50	0.50	C2P7447	2
K154	E	Install new front subframe rear bolts and re-torque front bolts - 5.0L Supercharged Only Drive in/drive out	05.10.50 10.10.10	0.50 0.10	C2P7447 -	2 -

Normal Warranty policies and procedures apply

SERVICE INSTRUCTION:



NOTE: 5.0L Supercharged only.

1. Remove the radiator splash shield (see TOPIx Workshop Manual section 501-02: Front End Body Panels).

All vehicles

2. **NOTE: Remove and replace only one bolt at a time.**



NOTE: Right-hand shown; left-hand similar.

Remove and discard the front subframe right-rear bolt.

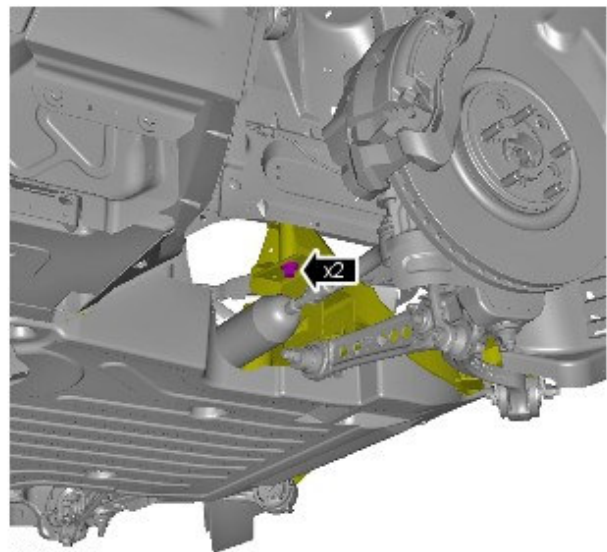

E150119

3. Install a new front subframe right-rear bolt.
 - Tighten the new bolt to 80Nm + 240°
4. Remove and discard the front subframe left-rear bolt.
5. Install a new front subframe left-rear bolt.
 - Tighten the new bolt to 80Nm + 240°

6.  **NOTE: Do not loosen / remove the bolts.**

With a torque wrench set to 250Nm (185 lbf ft), over-check the torque of the front subframe right-front and left-front bolts.

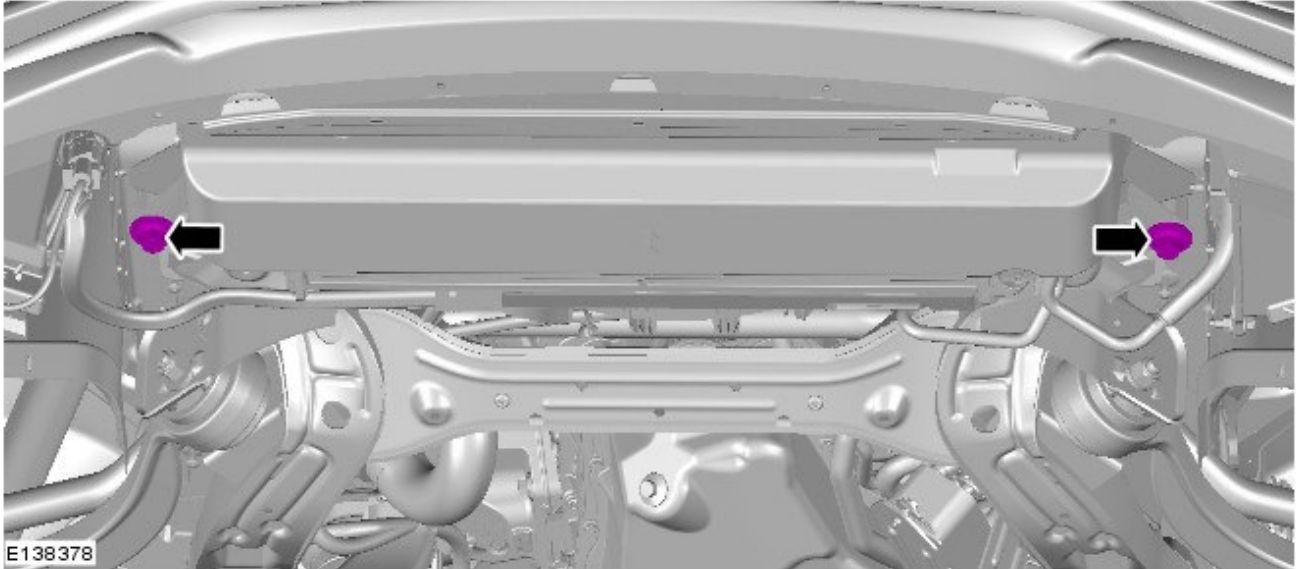

 **NOTE: 5.0L Supercharged only.**

7. Install the radiator splash shield (see TOPIx Workshop Manual section 501-02: Front End Body Panels).

8. Lower the vehicle.