

SB-10052549-8694

Repair Notice

413-1

Section

Engine

Description

2013 Cummins After-Treatment Fuse Rating

Release Date

6/4/2013

Revision History

06/12/2013 - Added Model 587 to the exclude list.

06/05/2013 - Updated the fuse panel hyperlink to an image

Introduction

It has been determined that all Conventional Model and Model 320 vehicles built with a Cummins 2013 EPA engine before 02/21/2013 may experience a loss of power to after-treatment components. Model 567/579/587 is NOT included in this campaign.

Expiration Date: 06/04/2014

Resolution

Change the 5 AMP fuse with a 10 AMP fuse on all eligible trucks. See attached procedure below for location of the AECU 5Amp fuse.

Warranty

Affected chassis are identified in SIR with "413-1".

Submit Quick Claim "**413-1**" for warranty claims associated with this repair.

Parts

Peterbilt will reimburse the dealer, dealer net + 30% to replace the 5 AMP fuse labeled AECU in the fuse panel with a 10 AMP fuse. Part number is M1N10.

Labor

Peterbilt Motors will reimburse up to **0.30** hours for this repair.

Procedure

Replace 5 AMP fuse AECU with a 10 AMP

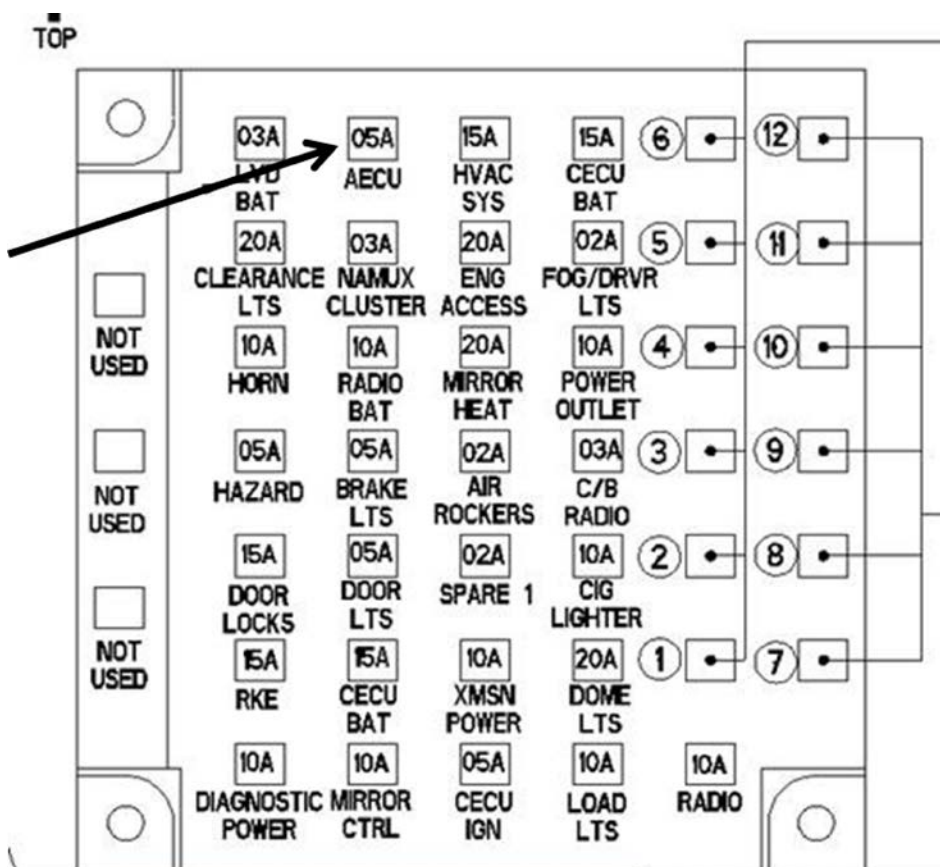

Attachments

[413-1 Chassis List](#)

413-1 Sample Customer Letter

Access to PACCAR's Enterprise Portal is provided as a benefit of doing business with PACCAR. All applications and content accessed through this system are confidential and proprietary and the property of PACCAR Inc and its suppliers, and must be kept strictly confidential pursuant to the contract licensing such access. Disclosure, publication, release or distribution of any material found on PACCAR systems to any person other than employees with a need to know such information is strictly prohibited. All activity on this system is monitored. If PACCAR suspects or discovers any unauthorized activity, access may be immediately terminated without prior notification. Violators may be subject to legal action.

© Copyright 2013 PACCAR Inc. All rights reserved. We welcome your [feedback](#) on this page. For technical questions or concerns about this page, please contact the [DealerNet Webmaster](#).