



Service Bulletin

File in Section: 03 - Suspension

Bulletin No.: 11-03-08-001A

Date: June, 2013

TECHNICAL

Subject: Growl Type Noise Coming from Front of Vehicle

Models: 2006-2013 Chevrolet Impala (Including Police Vehicles)
2014 Chevrolet Impala Limited (Including Police Vehicles)

This bulletin is being revised to add the 2012-2014 model years. Please discard Corporate Bulletin Number 11-03-08-001.

Condition

Some customers may comment on a growl type noise coming from the front of the vehicle at speeds between 32-80 km/h (20-50 mph).

Cause

This condition may be caused by loss of preload on the front wheel bearings.

Correction

Important: DO NOT replace the front wheel bearing and hub for this condition.

To diagnose the noise, retorque the existing front axle shaft nut to 220 N•m (162 lb ft) and test drive the vehicle. If the noise is eliminated, replace both front axle shaft nuts with GM P/N 10257766 and tighten to the specification indicated below. On vehicles equipped with the police package (RPOs 9C1 or 9C3), add an additional Nord-Lock washer, GM P/N 20861489, between the hub and nut as shown in the illustration below.

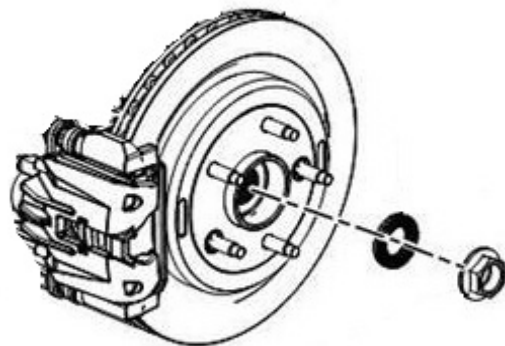

2623632

Application	Specification	
	Metric	English
Front Axle Shaft Nut	220 N•m	162 lb ft

Parts Information

Part Number	Description	Qty
10257766	Nut, Axle Shaft	2
20861489 (Police Vehicles Only)	Washer, Wheel Drive Shaft	2

Warranty Information

For vehicles repaired under warranty, use:

Labor Operation	Description	Labor Time
3080008*	Replace Both Front Axle Shaft Nuts to Correct Noise Concern	0.5 hr

*This is a unique labor operation for bulletin use only. It will not be published in the Labor Time Guide.

