

Applies To: **2013 Crosstour** – Check the iN VIN status for eligibility

February 6, 2013

Product Update: Seat Memory and Customized Door Lock Settings Can't Be Set

BACKGROUND

The customer's customized settings cannot be set because of a communication problem between the immobilizer control unit and the MICU.

CUSTOMER NOTIFICATION

Owners of affected vehicles will be sent a notification of this product update. An example of the customer notification is at the end of this service bulletin.

Do an **iN VIN status inquiry** to make sure the vehicle is shown as eligible.

Some of the vehicles affected by this product update may be in your new or used vehicle inventory. **These vehicles must be updated before they are sold or leased.** To see if a vehicle is affected by this campaign, do a VIN status inquiry before selling it, leasing it, or returning it to a service customer.

CORRECTIVE ACTION

Replace the immobilizer-keyless control unit.

NOTE: Make sure the customer has all of the keys before doing this repair.

PARTS INFORMATION

Immobilizer-Keyless Control Unit: P/N 39730-TY4-A01

WARRANTY CLAIM INFORMATION

Operation Number: 7251B7

Flat Rate Time: 0.5 hour

Failed Part: P/N 39730-T2A-A01

Defect Code: 5UF00

Symptom Code: S7800

Skill Level: Repair Technician

REPAIR PROCEDURE

1. Adjust the steering column to the full tilt down up position.
2. Remove the driver's dashboard lower cover.
 - Pull out the bottom of the cover to detach the clips.
 - Pull out along the edge of the cover to detach the clips.
 - Release the hooks.
 - Disconnect the VSA OFF switch connector.

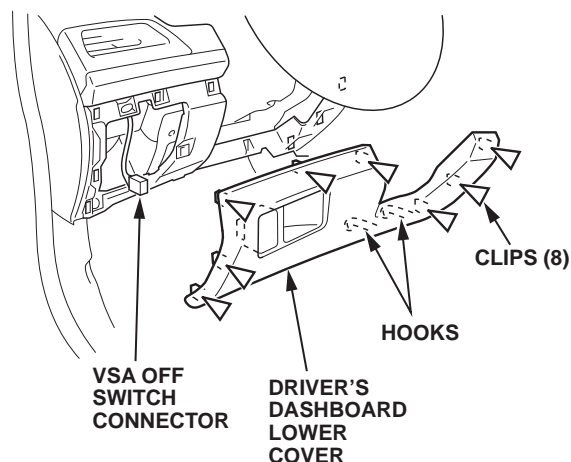

3. Remove the steering column covers.
- Adjust the steering column to the full tilt down position.
 - Pull out the column blind cover to detach the clips.

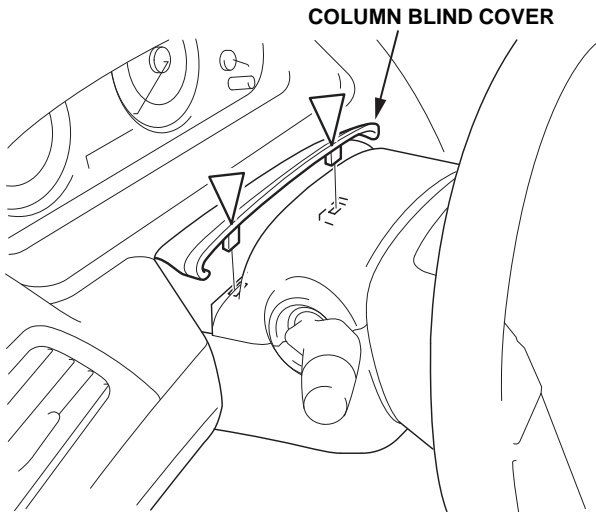

- Adjust the steering column to the full tilt down position, and to the full telescopic out position.
- Turn the steering wheel 90 degrees clockwise, then release the hook.

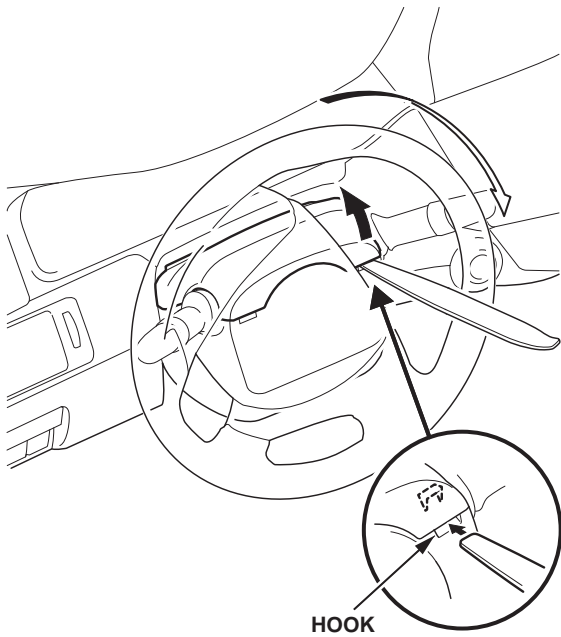

- Turn the steering wheel 180 degrees counterclockwise, then release the hook.

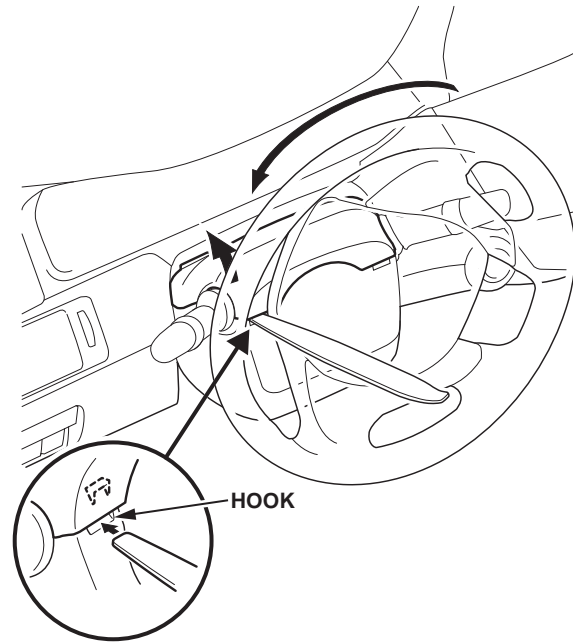

- Remove the upper column cover.

UPPER COLUMN COVER

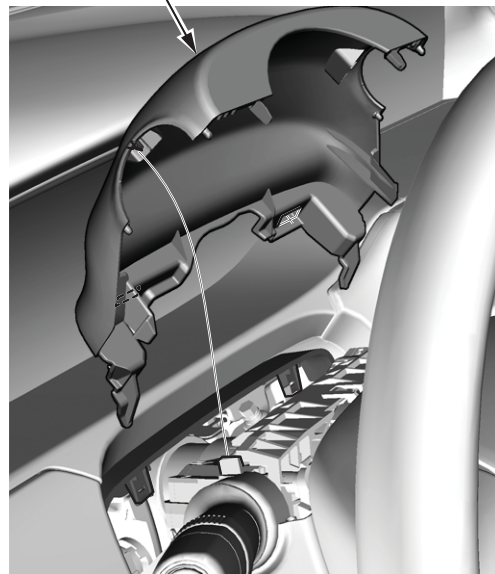

- Remove the screws.

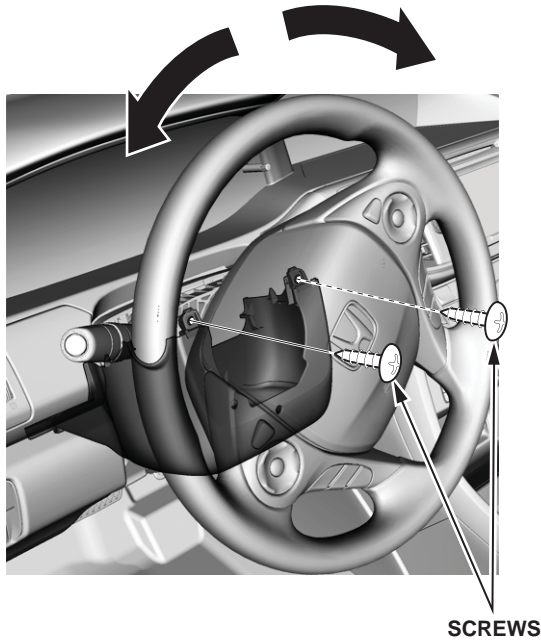

- Remove the lower column cover.

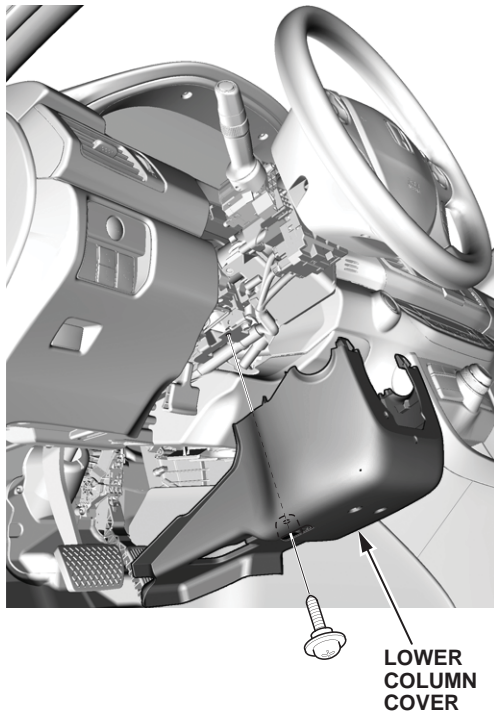

4. Disconnect the 7P connector from the immobilizer-keyless control unit.

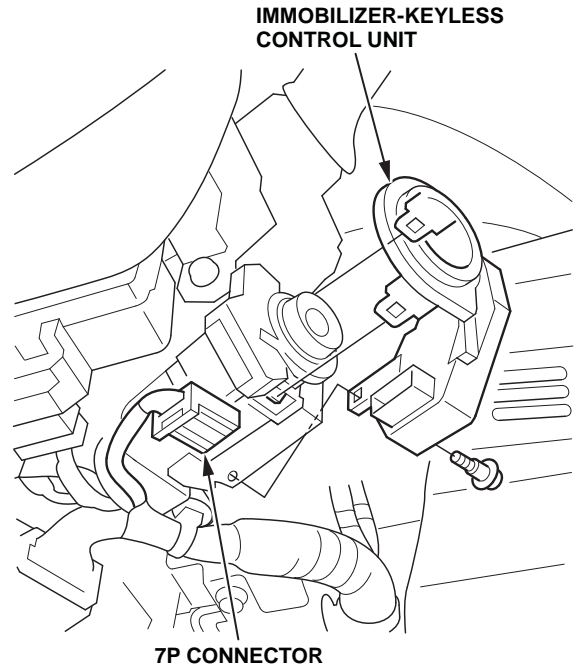

5. Remove the screw and the immobilizer-keyless control unit.
6. Install the new immobilizer-keyless control unit with the removed screw.
> Immobilizer-keyless control unit.
7. Reconnect the 7P connector to the immobilizer-keyless control unit.
8. Reinstall the column covers and the column blind cover.
9. Reinstall the dashboard lower cover and reconnect the VSA off switch connector.
10. Register the immobilizer-keyless control unit and program **all of the customer's keys**.

- **All programmed ignition keys (master and valet) for the vehicle.**
- PCM code. (This four-digit code is available on the iN. Go to SERVICE, select Vehicle Information from the left column, then select Immobilizer Code Inquiry.)
- HDS with the latest software.

NOTE: Make sure the market, the date, and the time on the HDS setup screen are correct. Select the **F12** key in the upper right corner to get the **Set-up Details** screen. Make sure **Market:** is set to **USA**. Select the time display in the lower right corner to get the **Date/Time Properties** pop-up window. Make sure the date and time are correct. For details, refer to the **Honda Diagnostic System (HDS) Setup Instructions** listed under **Tool Information** on-line.

- Make sure you have all registered keys and the PCM code.
- Connect the HDS to the data link connector (DLC).
- Turn the ignition switch to ON (II).
- Select IMMOBI from the SYSTEM SELECTION MENU, then select IMMOBILIZER SETUP.
- Select REPLACE IMMOBILIZER RECEIVER/CONTROL UNIT.
- Do the registration according to the instructions on the HDS screen.

NOTE: Program all of the customer's keys.

- When prompted by the HDS, do the keyless transmitter programming.
- Check that the engine can be started with all registered keys.
- Make sure the keyless remote operation works properly.

Example of Customer Letter

February 2013

Product Update: Seat Memory and Customized Door Lock Settings Can't Be Set

Dear Crosstour Owner:

This letter is to notify you of a potential problem with your vehicle and what you should do to resolve it.

What is the problem?

On some 2013 Crosstours, the seat memory and customized door lock settings cannot be set. The message "Unable to complete" comes on.

What should you do?

Contact any authorized Honda dealer for an appointment to have your vehicle's immobilizer-keyless control unit replaced. This work will be done free of charge. Please plan to leave your vehicle at the dealer for a half a day to allow them flexibility in scheduling.

Make sure you bring all of the keys to the vehicle. If you do not bring all of the keys with you, those keys will no longer work.

Lessor Information

If you are the vehicle lessor receiving this product update notice, please forward a copy of this notice to the lessee.

If you have questions

If you have questions about this notice, or need assistance with locating a Honda dealer, please call Honda Automobile Customer Service at 1-800-999-1009, and select option 4. You can also locate a dealer online at Hondacars.com.

What to do if you feel this notice is in error

Our records show that you are the current owner or lessee of a 2013 Crosstour involved in this product update. If this is not the case, or the name/address information is not correct, please fill out and return the enclosed, postage-paid Information Change Card. We will then update our records.

We apologize for any inconvenience this product update may cause you. Our goal is to ensure that your vehicle continues to be as reliable and enjoyable as possible.

Sincerely,

**American Honda Motor Co., Inc.
Honda Automobile Division**