



Program Bulletin



CUSTOMER SATISFACTION PROGRAM

SUBJECT: Clunking Noise When Turning

MODELS: 2013 Chevrolet Cruze

.....
THIS PROGRAM IS IN EFFECT UNTIL MAY 31, 2015.
.....

CONDITION

On **certain** 2013 model year Chevrolet Cruze vehicles, a possible tear in the passenger side steering gear boot may allow moisture and contamination to enter the boot. This could cause a clunking noise when making a turn. If this clunking noise is ignored and contamination continues to build, it could cause the loss of power steering assist.

CORRECTION

Dealers are to replace the passenger side steering gear boot on all vehicles. On customer vehicles, dealers are to also inspect the steering gear, and if signs of contamination are present, replace the steering gear.

VEHICLES INVOLVED

All involved vehicles are identified by Vehicle Identification Number on the Investigate Vehicle History screen in GM Global Warranty Management system. Dealership service personnel should always check this site to confirm vehicle involvement prior to beginning any required inspections and/or repairs. It is important to routinely use this tool to verify eligibility because not all similar vehicles may be involved regardless of description or option content.

For dealers with involved vehicles, a listing with involved vehicles containing the complete vehicle identification number, customer name, and address information has been prepared and will be provided to dealers through the GM GlobalConnect Recall Reports. Dealers will not have a report available if they have no involved vehicles currently assigned.

The listing may contain customer names and addresses obtained from Motor Vehicle Registration Records. The use of such motor vehicle registration data for any purpose other than follow-up necessary to complete this program is a violation of law in several states/provinces/countries. Accordingly, you are urged to limit the use of this report to the follow-up necessary to complete this program.

PART INFORMATION

Parts required to complete this program are to be obtained from General Motors Customer Care and Aftersales (GMCC&A). Please refer to your “involved vehicles listing” before ordering parts. Normal orders should be placed on a DRO = Daily Replenishment Order. In an emergency situation, parts should be ordered on a CSO = Customer Special Order.

Part Number	Description	Quantity/Vehicle
13354440	BOOT KIT,S/GR	1
13423005	GEAR,STRG (W/ MOT)	1 (if req'd)
13253472	BOLT, S/GR	2 (if strg gear replaced)
11546593	NUT, S/KNU	2 (if strg gear replaced)
11609282	NUT (stabilizer shaft link & outer tie rod)	4 (if strg gear replaced)
11588723	BOLT (stabilizer shaft insulator clamp)	2 (if strg gear replaced)
11561374	BOLT, FRT SUSP SUPT	2 (if strg gear replaced)

SERVICE PROCEDURE**Special Tools**

CH-22610 Keystone Clamp Pliers

Note: Perform boot inspection and replacement on the passenger side of vehicle only.

Vehicles in dealer inventory require replacement of steering gear boot only. The inspection of the steering gear is NOT required.

Customer vehicles require replacement of the steering gear boot and the inspection of the steering gear. If the steering gear displays signs of contamination, the steering gear is to be replaced.

1. Raise and support the vehicle. Refer to *Lifting and Jacking the Vehicle* in SI.
2. Remove the steering linkage outer tie rod. Refer to *Steering Linkage Outer Tie Rod Replacement* in SI.
3. Remove the steering linkage inner tie rod nut.

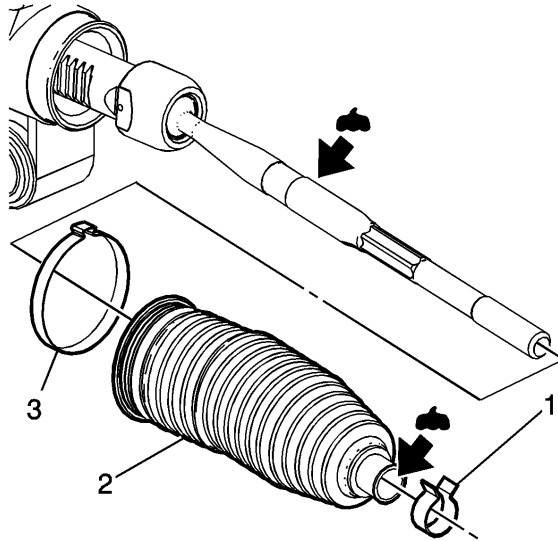

2375391

4. Remove the outer boot clamp (1). Discard the clamp.
5. Cut or otherwise remove the inner boot clamp (3). Discard the clamp.
6. Remove the steering gear boot (2). For vehicles in dealer inventory, proceed to Step 9. For customer vehicles, proceed to the next step.

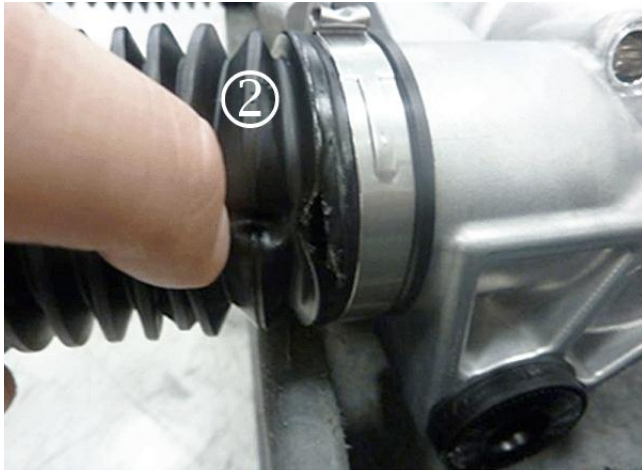

3359424

7. Inspect steering gear boot (2) for cut (reference picture) on the side facing downwards in vehicle. Discard the boot.
8. Inspect inner tie rod, inner steering gear boot (2), and surrounding internal areas for any evidence of moisture (such as rust) or environmental contamination (such as sand, dirt, or grime). Note: the discoloration on exterior of gear housing does not indicate leakage and should not be used to determine the integrity of the interior of the steering gear.
 - If evidence of contamination is apparent, replace the steering gear. Refer to *Steering Gear Replacement* in SI.
 - If contamination is NOT present, replace only the steering gear boot (2) using Boot Kit P/N 13354440. Proceed to Step 9.

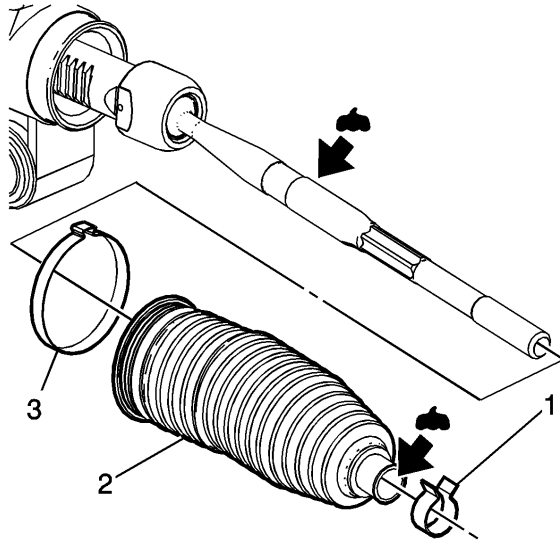

2375391

Note: The steering linkage inner tie rod and the steering gear boot must be free of moisture and debris.

9. Apply lubricant to both inner ends of the steering gear boot (2).

Note: Ensure the larger end of the steering gear boot is firmly seated in the correct location on the steering gear.

10. Install the steering gear boot with the NEW inner boot clamp (3) loosely attached.

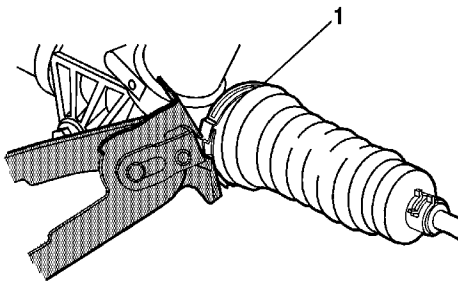

1865916

11. Use the CH-22610 pliers in order to install the NEW inner boot clamp (1).

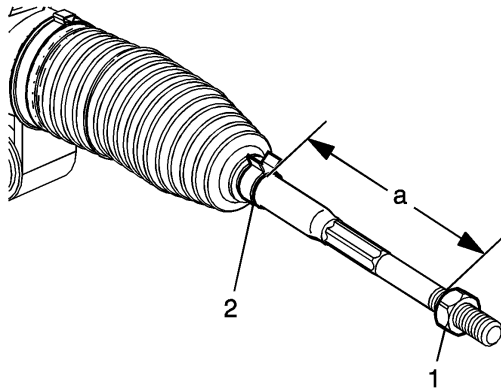

2375395

Note: Ensure the small end of the steering gear boot is firmly seated in the correct location on the steering linkage inner tie rod.

12. Install the NEW outer boot clamp (2)
13. Install the steering linkage inner tie rod nut (1).
14. Install the steering linkage outer tie rod. Refer to *Steering Linkage Outer Tie Rod Replacement* in SI.
15. Measure and adjust the front toe. Refer to *Wheel Alignment – Steering Wheel Angle and/or Front Toe Adjustment* in SI.
16. Lower the vehicle.

COURTESY TRANSPORTATION – For US and Canada

The General Motors Courtesy Transportation program is intended to minimize customer inconvenience when a vehicle requires a repair that is covered by the New Vehicle Limited Warranties. The availability of courtesy transportation to customers whose vehicles are within the warranty coverage period and involved in a product program is very important in maintaining customer satisfaction. Dealers are to ensure that these customers understand that shuttle service or some other form of courtesy transportation is available and will be provided at no charge. Dealers should refer to the General Motors Service Policies and Procedures Manual for Courtesy Transportation guidelines.

WARRANTY TRANSACTION INFORMATION

Submit a transaction using the table below. All transactions should be submitted as a ZFAT transaction type, unless noted otherwise.

Labor Code	Description	Labor Time
V2813	Replace Steering Gear Boot Only (vehicles in dealer inventory)	1.3
V2814	Replace Steering Gear Boot Only (inc. inspect) (customer vehicles)	1.4
V2815	Replace Steering Gear (inc inspect, steering gear boot & wheel align) (customer vehicles only)	3.0

CUSTOMER NOTIFICATION – For US and Canada

General Motors will notify customers of this program on their vehicle (see copy of customer letter included with this bulletin).

CUSTOMER NOTIFICATION – For Export

Letters will be sent to known owners of record located within areas covered by the US National Traffic and Motor Vehicle Safety Act. For owners outside these areas, dealers should notify customers using the attached sample letter.

DEALER PROGRAM RESPONSIBILITY

All unsold new vehicles in dealers' possession and subject to this program must be held and inspected/repaired per the service procedure of this program bulletin before customers take possession of these vehicles.

Dealers are to service all vehicles subject to this program at no charge to customers, regardless of mileage, age of vehicle, or ownership, through May 31, 2015.

Customers who have recently purchased vehicles sold from your vehicle inventory, and for which there is no customer information indicated on the involved vehicle listing, are to be contacted by the dealer. Arrangements are to be made to make the required correction according to the instructions contained in this bulletin. A copy of the customer letter is provided in this bulletin for your use in contacting customers. Program follow-up cards should not be used for this purpose, since the customer may not as yet have received the notification letter.

In summary, whenever a vehicle subject to this program enters your vehicle inventory, or is in your facility for service through May 31, 2015, you must take the steps necessary to be sure the program correction has been made before selling or releasing the vehicle.



May 2013

Dear General Motors Customer:

We have learned that on your 2013 model year Chevrolet Cruze, a possible tear in the passenger side steering gear boot may allow moisture and contamination to enter the boot. This could cause a clunking noise when making a turn. If this clunking noise is ignored and contamination continues to build, it could cause the loss of power steering assist.

Your satisfaction with your Chevrolet Cruze is very important to us, so we are announcing a program to prevent this condition or, if it has occurred, to fix it.

What We Will Do: Your GM dealer will install a new passenger side steering gear boot. Your dealer will also inspect the steering gear, and if signs of contamination are present, replace the steering gear. This service will be performed for you at **no charge until May 31, 2015**. After that, any applicable warranty will apply.

What You Should Do: To limit any possible inconvenience, we recommend that you contact your dealer as soon as possible to schedule an appointment for this repair. By scheduling an appointment, your dealer can ensure that the necessary parts will be available on your scheduled appointment date.

If you have any questions or concerns that your dealer is unable to resolve, please contact the appropriate Customer Assistance Center at the number listed below.

Division	Number	Text Telephones (TTY)
Chevrolet	1-800-222-1020	1-800-833-2438
Guam	65-6267-1752	
Puerto Rico – English	1-800-496-9992	
Puerto Rico – Español	1-800-496-9993	
Virgin Islands	1-800-496-9994	

Courtesy Transportation: If your vehicle is within the New Vehicle Limited Warranty, your dealer may provide you with shuttle service or some other form of courtesy transportation while your vehicle is at the dealership for this repair. Please refer to your Owner Manual and your dealer for details on Courtesy Transportation.

We sincerely regret any inconvenience or concern that this situation may cause you. We want you to know that we will do our best, throughout your ownership experience, to ensure that your Chevrolet Cruze provides you many miles of enjoyable driving.

Jim Moloney
General Director,
Customer and Relationship Services