



## SP 4-286-002

# SERVICE PROGRAM

May, 2013

### Attention:

Service Managers / Parts Managers

### Subject:

Transmission Oil Cooler (TOC) replacement for certain Xpeditor trucks with ISX engines.

### Description of Service Program:

This Service Program provides instructions to obtain replacement parts and replace the TOC on certain ACX-cab Xpeditor trucks equipped with Allison® transmission retarders. Program Expires: May 15, 2014

### Vehicles Affected:

There are 5 affected vehicles with serial numbers in the range 215267 through 215870. Note that there are different Service Programs for different vehicle/engine configurations. Refer to the VIN list beginning on Page 14.

### Service Responsibility:

Service Programs are performed on eligible vehicles at no charge to the owner until the expiration date listed above.

### Service Program Information:

Service Programs are product modifications and/or product improvements that Autocar has determined will enhance the operation of the truck. In a continuing effort to inform our customers of potential service issues and avoid unnecessary down time, Autocar has identified the following operation as recommended preventive maintenance. This Service Program should be added to your preventive maintenance and service manuals.

While being committed to continuous product improvement, Autocar is not liable for updating existing chassis after they have been placed in service.

Questions regarding this Service Program should be directed to Autocar Technical Support at 888-218-3611.

### Required Parts:

- (1) S2860007K001 SVC KIT
  - (1) 02-7118457 Hose
  - (1) A2040183-001 Elbow
  - (1) A2040184-001 Transition pipe
  - (1) A2040185-001 Pipe, coolant
  - (1) A2860178-001 Trans oil cooler
  - (1) A2860187-002 Mounting plate
  - (4) GZ220015-006 Hose clamp
  - (1) GZ240027-001 Hose
  - (1) GZ250017-001 #12 SAE O-ring
  - (1) GZ250017-002 #12 Facial seal O-ring
  - (4) GZ250017-003 #20 SAE O-ring
  - (2) GZ250017-004 #20 Facial seal O-ring
  - (1) S2860008K001 Hardware kit
    - (4) GE286237B001 Locknut

**SP 4-286-002**

# SERVICE PROGRAM

May, 2013

## To Obtain Parts:

Ensure that you have authorization from the customer to perform this work, and send an e-mail to [warranty@autocartruck.com](mailto:warranty@autocartruck.com) which includes the following:

- VIN(s) (or last 6 digits of VIN(s))
- 'Attention To' name
- 'Ship To' address

NOTE that the parts for this Service Program are fragile and heavy and require special packaging and shipment. The parts will be shipped on a pallet by truck and can NOT be delivered overnight. Delivery may take 3-10 days depending on volume and location.

## Claims for Reimbursement:

Submit a claim for reimbursement in accordance with Autocar's Warranty Administration Manual.

## Claim Coding Information:

Labor Operation Code Number	Time Allowance SRT	Description
49101-5-03	4.5 HR	Trans Oil Cooler Replacement

## Tools Required:

- 1/2" drive 9/16" socket
- 1/2" drive 5/8" socket
- 1/2" drive 7/16" socket
- 1/2" drive 3/4" socket
- 1 7/8" combination wrench
- 1 3/8" combination wrench
- 3/4" combination wrench
- 1/2" drive torque wrench capable of 150 Ft. Lb (203 Nm)
- 15 gallon (57 liter) drain pan
- 5 gallon (19 liter) drain pan

## Safety Notices



### WARNING

Allow the vehicle's engine and cooling system to cool to ambient temperature before performing the repair procedure. A hot engine or cooling assembly may cause burns or other personal injury.



### WARNING

To prevent eye injury, always wear eye protection when performing vehicle maintenance, service or inspection.



### WARNING

Before working on a vehicle, set the parking brake, place the transmission in neutral and block the wheels. Failure to do so can result in unexpected vehicle movement and can cause serious personal injury or death.



### WARNING

Take proper precautions before working under the vehicle. Use ramps approved for the weight of your vehicle, or use floor jacks and stands. Never work under a vehicle supported by jacks alone. Always use jack stands to support the vehicle.

SP 4-286-002

**SERVICE PROGRAM**

May, 2013

**CAUTION****LOCKOUT/TAGOUT  
PROCEDURES**

Before entering the vehicle or vehicle body, read and follow OSHA regulations concerning entry and working in "CONFINED SPACE" OSHA 1910.146 and "LOCKOUT/TAGOUT" OSHA 1910.147. Follow OSHA regulations while performing any work on the vehicle. The vehicle must be disabled by the following steps before performing any work on the vehicle:

1. Place the transmission in NEUTRAL.
2. Set the parking brake.
3. Shut the engine OFF.
4. Lock cab doors, keep the key in your pocket. Block the wheels before entering the body or performing any work on the vehicle.
5. Turn the battery disconnect switch OFF, if equipped.
6. Completely drain the air from the primary/A system and secondary/B system by opening the drain valves on the air tanks themselves or by using the drain manifold if supplied. When draining the air tanks, do not look into the area where air is draining. Dirt or sludge particles may be expelled in the air stream and can cause eye injury.
7. Place magnetic "DANGER" signs on both cab doors before entering the body or performing any work on the vehicle.
8. Take proper precautions before working under the vehicle. Use ramps approved for the weight of your vehicle, or use floor jacks and stands. Never work under a vehicle supported by jacks alone. Always use jack stands to support the vehicle.

## SP 4-286-002

# SERVICE PROGRAM

May, 2013

### REPLACING THE TOC

#### Draining the Cooling System and Removing the TOC

1. After turning the key to the "OFF" position, remove the key and allow sufficient time for the vehicle to cooled down completely.
2. Raise the cab in accordance with the following safety precautions and procedures.



### WARNING

Due to the danger of sustaining personal injury and/or damage to the vehicle, never attempt to raise the cab outdoors under extremely windy conditions. Strong wind conditions could force the cab beyond the normal limits of its travel. Never rely on the hydraulic pressure to hold the cab in an open position. Always use the safety pin in the cab tilt lock tube to prevent serious personal injury or death.



### WARNING

Remove or secure all loose articles and close all doors before raising the cab. The area above and ahead of the cab must be clear from obstructions. Place front wheels in a straight ahead position.

Remove the pump handle from its storage on the inside of the cab near the driver or passenger seat.

Place the selector lever on the hydraulic pump in the RAISE position. Insert the pump handle into the pump and operate the handle in an up and down motion. The hydraulic cab latches will open, then the hydraulic cylinders will lift the cab until the midpoint (top) is reached.

Once the cab has reached its midpoint the cab will move forward to the fully open position. The safety pin in the cab tilt lock device must be installed when the holes line up in the sliding bar.

Remove the pump handle when not in use. It may stick out and could cause injury to passersby.

## SP 4-286-002

# SERVICE PROGRAM

May, 2013



### WARNING

**Do not remove the pressure cap from a hot engine. Wait until the coolant temperature is below 50°C [120°F] before removing the pressure cap. Heated coolant spray or steam can cause personal injury.**

3. Remove the cooling system pressure cap.



### WARNING

**Coolant is toxic. Keep away from children and pets. If not reused, dispose of in accordance with local environmental regulations**

**Note:** *The drained engine coolant will be reinstalled at the end of the repair procedure. Ensure that the engine coolant is drained and kept separate from the drained transmission fluid. Use two separate drain pans as noted.*

4. If equipped with an oil pan guard (skid plate), remove the 6 fasteners and set aside (fasteners and oil pan guard) for reinstallation (*see Figure 1*).
5. Using a 15-gallon (57-liter) drain pan, drain the cooling system by opening the drain valve on the radiator and the drain valve on the bottom of the engine oil cooler housing. Remove the TOC drain plug to completely drain the TOC (*see Figure 3*).

6. After the cooling system is completely drained, close the drain valves. Set the captured coolant aside for reinstallation. Refer to the engine manufacturer's instructions for complete cooling system drain procedure and information.

**SP 4-286-002**  
**SERVICE PROGRAM**

May, 2013

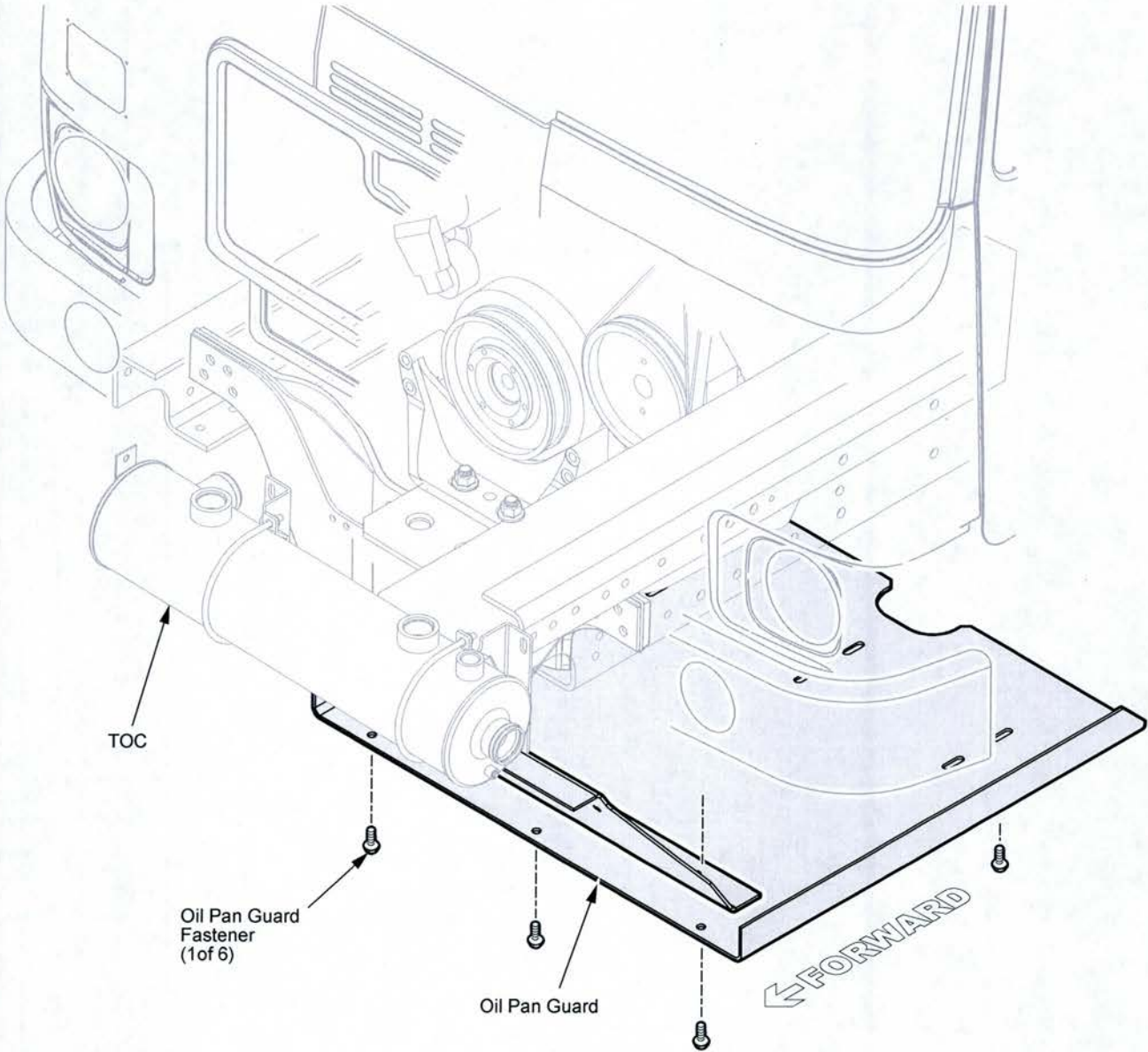

**Figure 1**

# SP 4-286-002 SERVICE PROGRAM

May, 2013

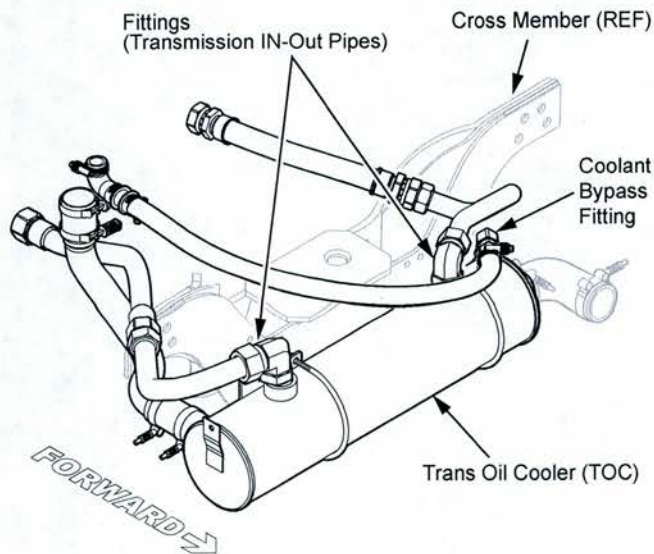
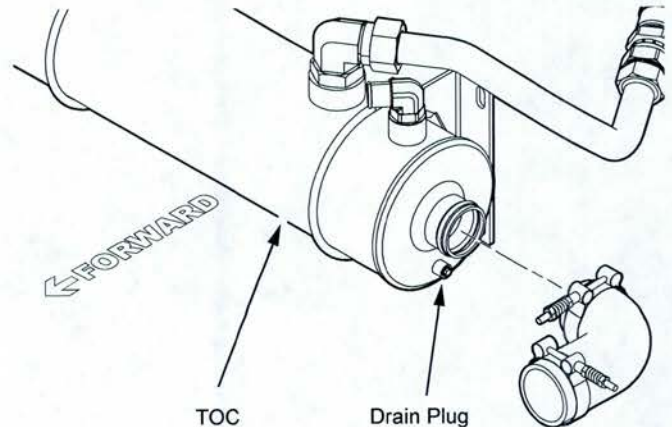

**Figure 2**

**Note:** The drained engine coolant will be reinstalled at the end of the repair procedure. Ensure that the engine coolant is drained and kept separate from the drained transmission fluid. Use two separate drain pans as noted.

- Remove the coolant bypass fitting from the TOC. Remove and discard the O-rings from the fitting and set the fitting aside for reinstallation (see Figure 2).

**Note:** Pay particular attention to the orientation of fittings, for reinstallation. Remove the O-rings from the fittings and discard (see Figure 2).

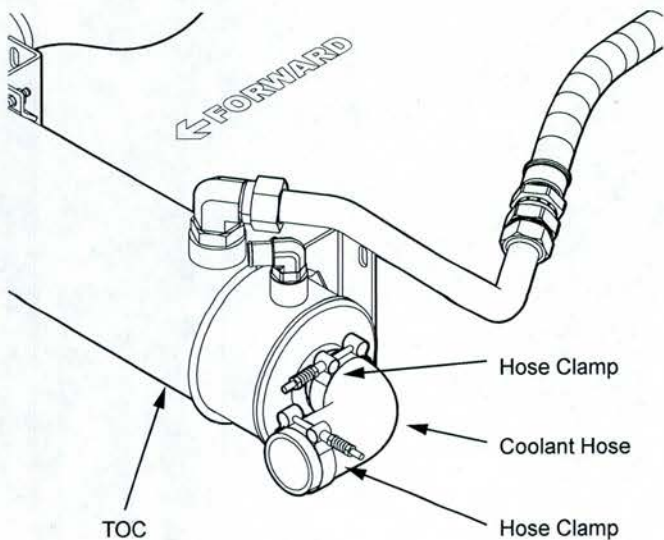

**Figure 3**

- Position a 5-gallon (19-liter) drain pan beneath the transmission fluid pipe fittings. Disconnect the 2 transmission fluid pipes from the fittings and remove the fittings from the TOC. Remove and discard the O-rings from the fittings and place the fittings aside for reinstallation. Discard the captured transmission fluid (see Figure 3).

**SP 4-286-002**  
**SERVICE PROGRAM**

May, 2013



**Figure 4**

9. Disconnect the coolant hose (see Figure 4).

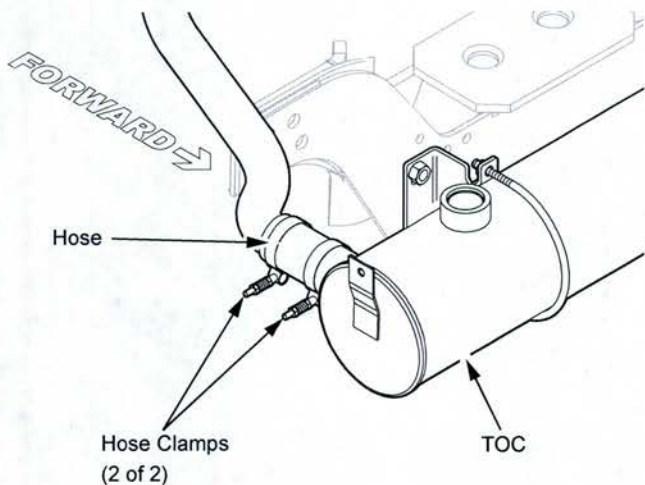

**Figure 5**

10. Loosen the clamps and remove the coolant hose (see Figure 5).

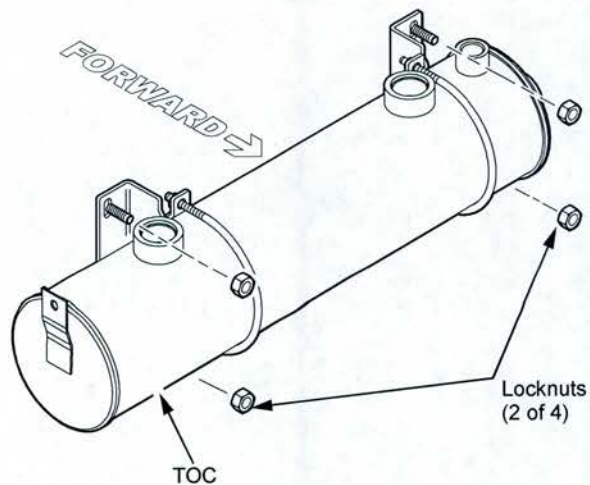
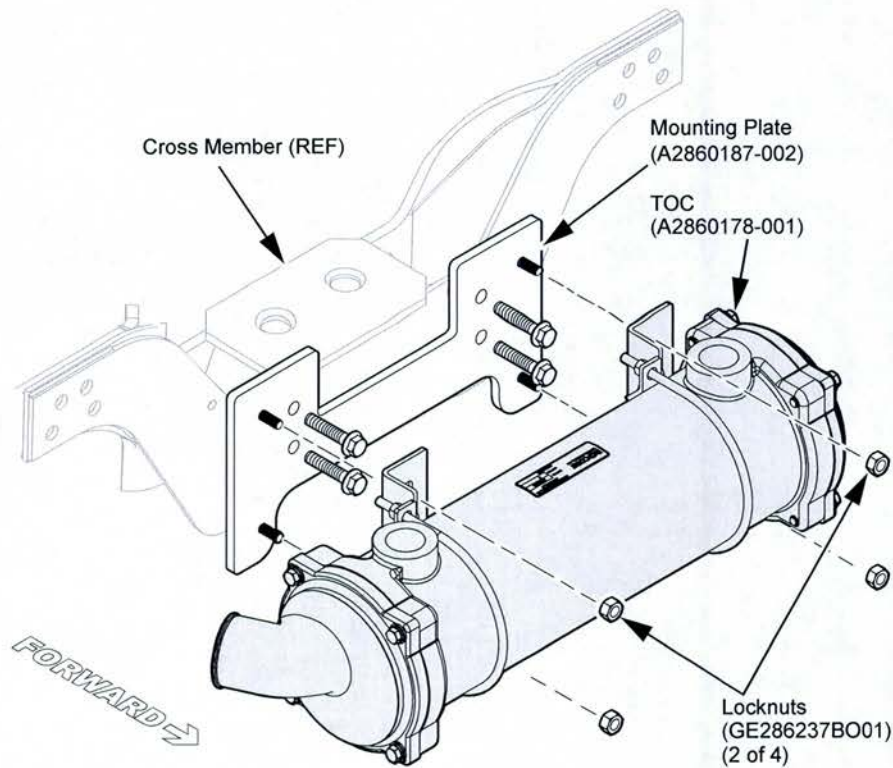

**Figure 6**

11. Remove the 4 fasteners securing the TOC to the cross member and discard the fasteners (see Figure 6).
12. Remove the TOC and discard.

# SP 4-286-002 SERVICE PROGRAM

May, 2013



**Figure 7**

## Installing the New TOC

13. Using 4 bolts, install the mounting plate (A286187-002) onto the cross member. (see Figure 7).

14. Install the new TOC (A2860178-001) onto the studs on the mounting plate. Install the 4 locknuts (GE286237BO01). Tighten to 45 ft-lb (61 N-m) of torque (see Figure 7).

# SP 4-286-002 SERVICE PROGRAM

May, 2013

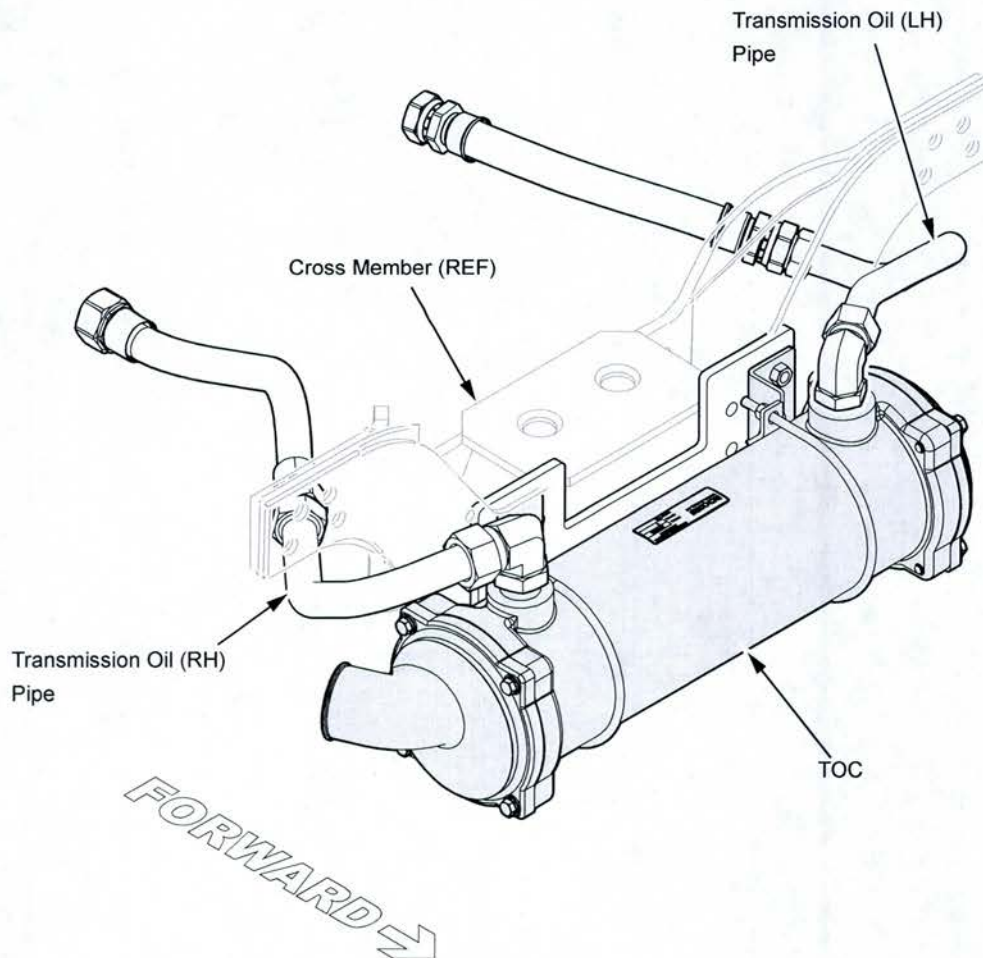

**Figure 8**

**Note:** Lubricate the O-rings and threads on the fitting with hydraulic oil prior the installation.

15. Locate the transmission pipe fittings which were set aside in step 8. Install 1 SAE O-ring (GZ250017-003) to each of the fittings leading to the TOC and 1 facial seal O-ring (GZ250017-004) to each of the fittings leading to transmission oil pipes. Install the fittings

into the new TOC; then, connect the TOC pipes (RH/LH) to the fittings. Orient the fittings as noted during removal in step 8. Tighten to 150 ft-lb (203 N-m) of torque (see *Figure 8* and *Figure 10*)

# SP 4-286-002 SERVICE PROGRAM

May, 2013

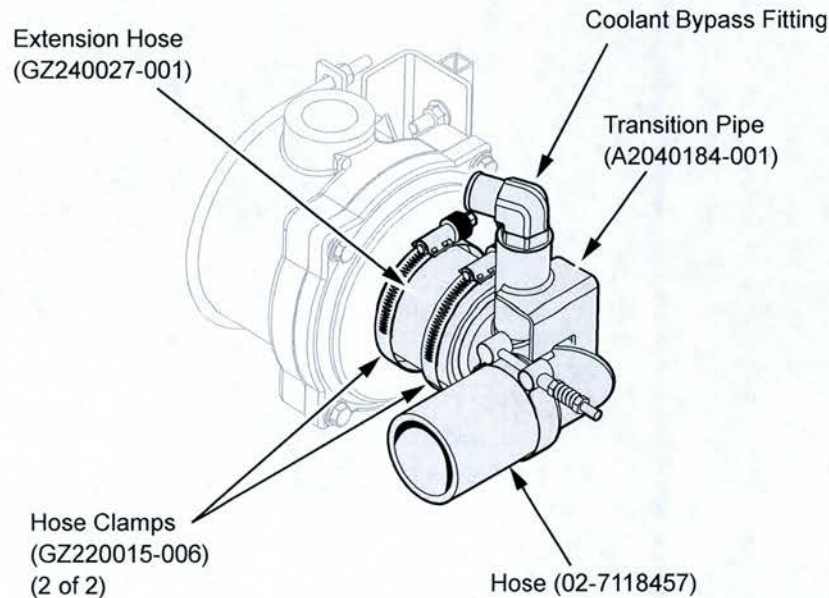

**Figure 9**

16. On the LH side of the TOC, install the extension hose (GZ240027-001) and 2 hose clamps (GZ220015-006) (see Figure 9).
17. On the LH side of the TOC, install the transition pipe (A2040184-001) onto the extension hose and tighten the 2 hose clamps to 60 In-lb (7 N-m) of torque (see Figure 9).

**Note:** Lubricate the O-rings and threads on the fitting with hydraulic oil prior the installation.

18. On the coolant bypass fitting that was set aside in step 8, install 1 SAE O-ring (GZ250017-001) to the fittings leading to the TOC and 1 facial seal O-ring (GZ250017-002) to the fittings leading to

the coolant bypass hose. Install the fitting onto the transition pipe; then, connect the coolant bypass hose to the fitting. Tighten to 85 ft-lb (115 N-m) of torque (see Figure 9 and Figure 10).

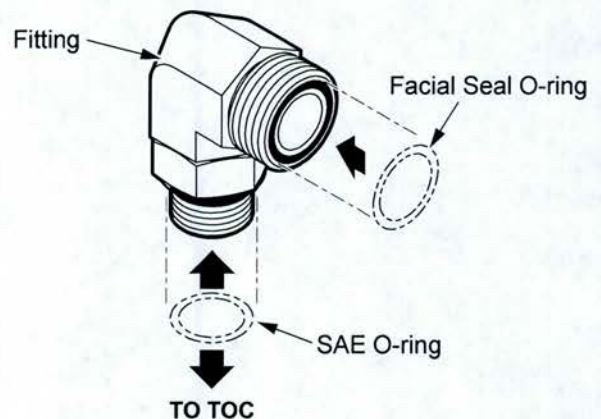
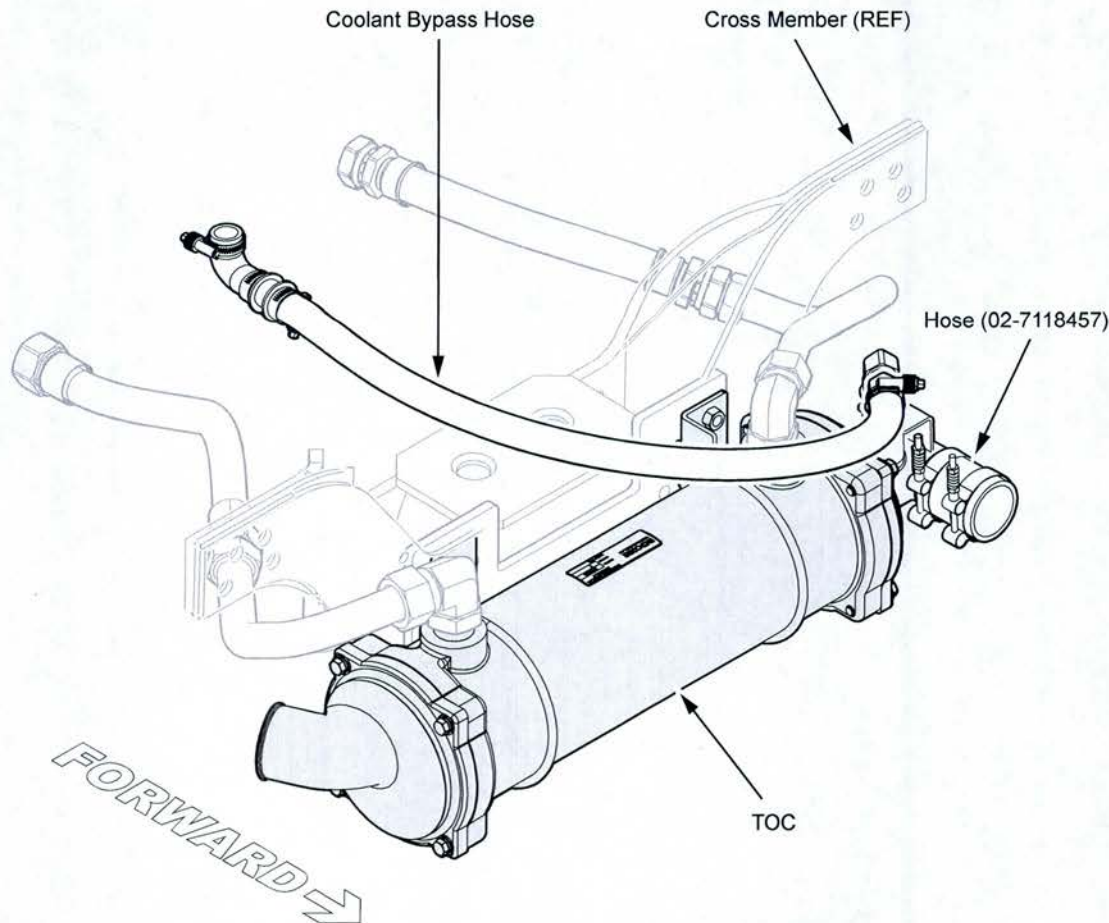

**Figure 10**

# SP 4-286-002

## SERVICE PROGRAM

May, 2013

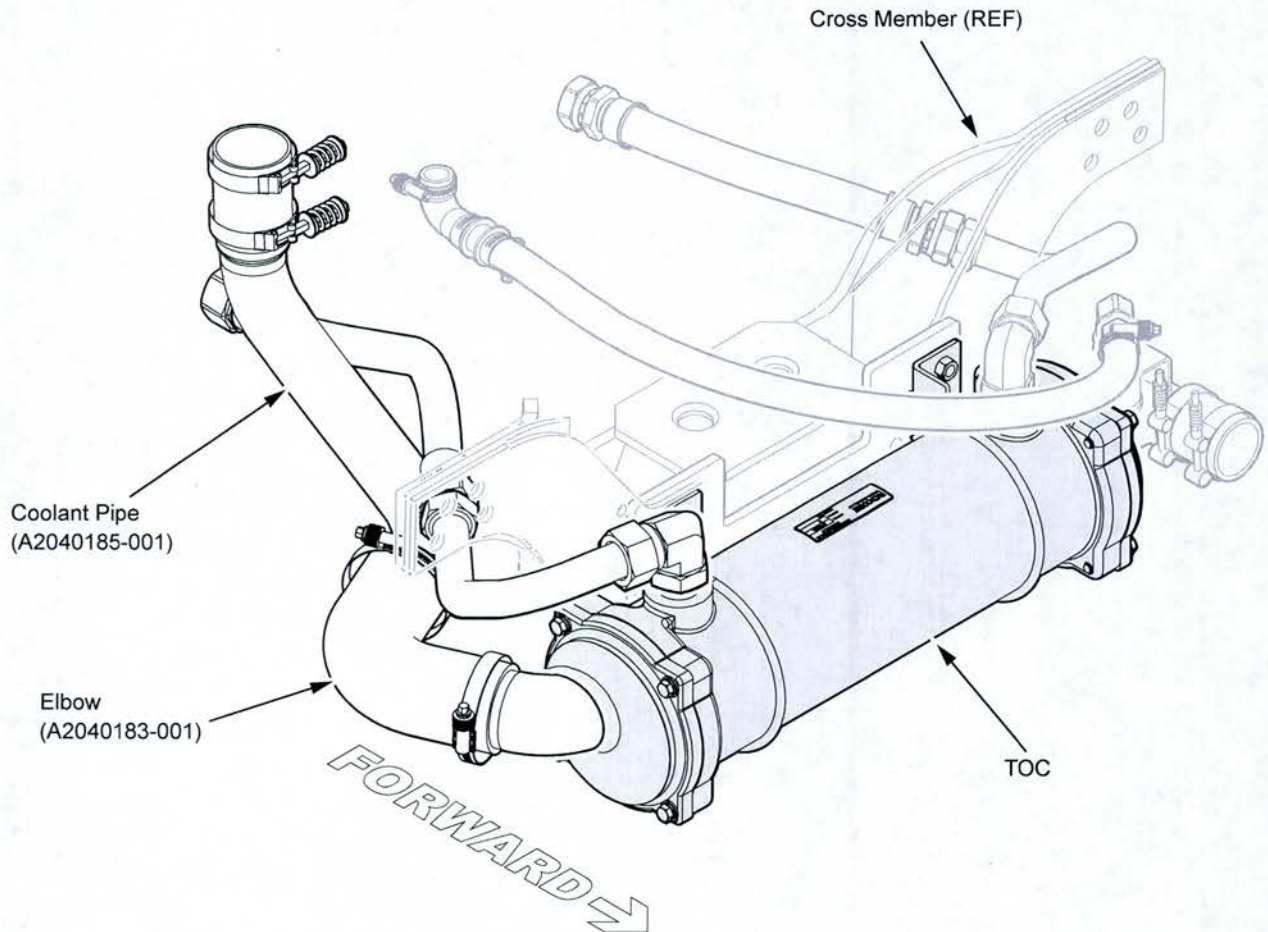

**Figure 11**

19. On the LH side of the TOC, install the hose (02-7118457) and 2 hose clamps (see Figure 11).
20. On the RH side of the TOC, using 2 hose clamps (GZ220015-006), install the elbow (A2040183-001). Tighten the hose clamps to 60 In-lb (7 N-m) of torque (see Figure 12).
21. Install the coolant pipe (A2040185-001) onto the elbow (see Figure 12).
22. Check for damaged hoses and loose or damaged hose clamps. Replace as required.
23. Check the radiator for damage and/or buildup of dirt. Clean and replace as required.

# SP 4-286-002 SERVICE PROGRAM

May, 2013



**Figure 12**

24. Reinstall the previously captured engine coolant. Refer to the engine manufacturer's instructions for complete cooling system fill procedure and information.
25. Top off the transmission fluid using only Allison® approved synthetic oil.
26. Pressure test the cooling system to 16 psi.
27. If equipped, reinstall the oil pan guard. Tighten the 6 fasteners to 80 ft-lbs (108 N-m) of torque.
28. Lower the cab.
29. Operate the unit to verify the installation and inspect for any leaks. Once verified, the replacement of the TOC is complete.

**SP 4-286-002**  
**SERVICE PROGRAM**

**May, 2013**

---

5VCACL7F4DH215267

5VCACS6F0DH215469

5VCACL6F6DH215868

5VCACL6F8DH215869

5VCACL6F4DH215870