

Boston-MBTA: Chassis Inspection



Prepared by: Kalman Takacs
Field Service Engineer
256-241-1243

Approved By: Dan Allen
Chief Engineer

Property and Top Bus Number: Boston 40LFW-24, 81000

Issue: Chassis inspection.

Reason/ cause: Periodically inspection of the chassis and suspension components is required per the Maintenance Manual.

Solution: Inspect chassis and suspension components per this work instruction.

Boston-MBTA: Chassis Inspection



Number of affected buses: as required

Estimate inspection hours/bus: 45 min for the regular visual inspection
90 min for the first initial ultrasound testing

Necessary parts:

NA

Necessary tools:

Digital camera scope and ultrasound tester



Flash light, wire brush, Penetrate test kit (cleaner-, penetrate- and developer sprays)



Boston-MBTA: Chassis Inspection



SAFETY PRECAUTIONS MUST BE FOLLOWED ACCORDING TO ACCEPTED INDUSTRY STANDARDS AND LOCAL/PROPERTY REQUIREMENTS.

Introduction:

Inspect the bus chassis starting from the front of the bus. Inspect the areas detailed in this work instruction, including the surrounding tube frames for the following discrepancies:

- a. Cracks
- b. Broken welds
- c. Flaking/corroded material
- d. Any other damage

Basic crack inspection procedure:

Note: visual inspection is periodically required per the NABI Maintenance Manual.

- Visually check suspected area.
- If rust is present then clean the area with wire brush or wire wheel. **Do not use grinding wheel** because it makes the surface rough and the crack detection becomes more difficult.
- Use magnifying glass to identify crack.
- Use penetrate kit as required. Follow instruction written on the cans.
- If crack was found mark the location, measure the length, take some photos and notify NABI.

Using the digital camera scope and ultrasound tester:

Note: ultrasound tester must be used for the first initial inspection on every bus. According to the result of inspection, NABI will advise if further ultrasound testing is required. The camera scope may be used during the first initial inspection and later during the regular inspection if required (see details below).

- Remove plastic plugs (wax plugs) from structural tubes and see if water drains out.
- If excessive water was present inside the structural tubes then drill 12 mm (1/2") diameter drain holes according to the instructions from NABI representatives (see details starting at page 10).
- The interior conditions of certain suspicious structural tubes (especially where water was present inside) can be checked by using digital camera scope. See details at paragraph 4th about what structural tubes need to be inspected this way.
- The wall thickness of the steel tubes must be checked by ultrasound tester during the first initial inspection. See details at paragraph 5th about what structural tubes must be inspected by using ultrasound tester.

Boston-MBTA: Chassis Inspection



Chassis inspection:

1. Turn the battery disconnect switches off.
2. Lift the bus and place jack stands underneath the official jacking pads.
3. Inspect the chassis starting from the front of the bus. Check the following areas:
 - Front skid plate area. If damage visible on the skid plates that indicates possible low ride height and/or rough driving conditions (driver error and bad road conditions).



Boston-MBTA: Chassis Inspection



- Check the steering miter box mounting area.



- Check the steering gear mounting area.



Boston-MBTA: Chassis Inspection



- Check the curb side (CS) and street side (SS) lower radius rods mounting areas. If the area was repaired before then inspect the welds and new parts (if any) closely.



- Check the curb side (CS) and street side (SS) upper radius rods mounting areas.



Boston-MBTA: Chassis Inspection



- Check the CS and SS upper and lower shock absorber mounting areas.

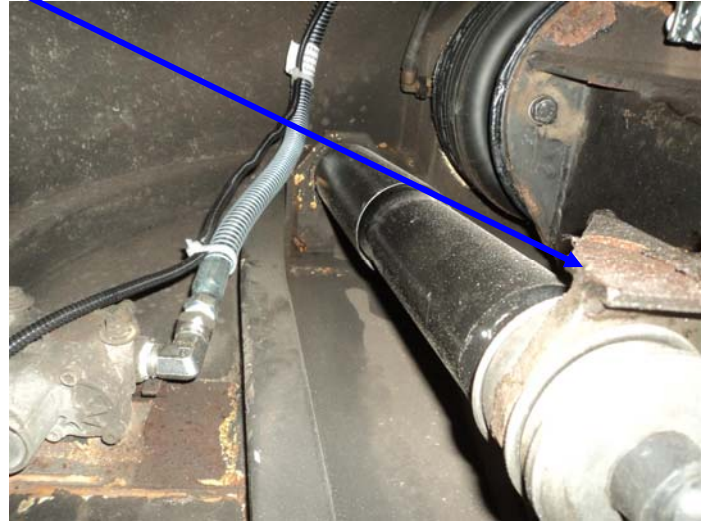
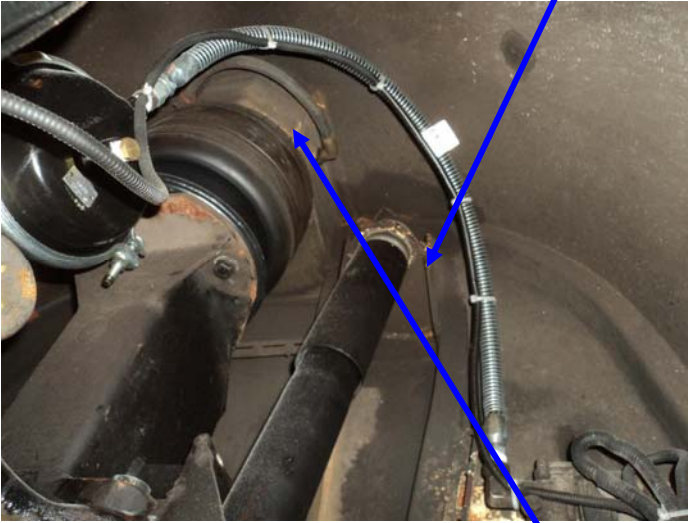

- Check the CS and SS airbag mounting areas from underneath the bus.
- Check the CS and SS lower radius rod axle-side mounting brackets.



Boston-MBTA: Chassis Inspection



- Check the rear axle lower CS and SS radius rods mounting bracket area.



- Check the rear upper CS and SS radius rod mounting area.
- Check the rear axle mounting frames (C-frames) around the airbag, shock absorber and axle mounting areas.

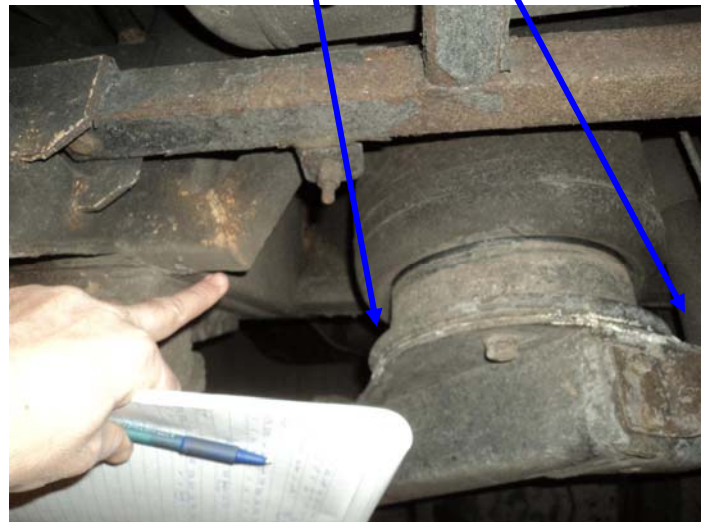

Boston-MBTA: Chassis Inspection



- Check the rear upper CS and SS shock absorber mounting areas.



- Check the rear upper CS and SS airbag mounting areas.
- Check the engine cradle where the engine is mounted to it and where the cradle is mounted to the bus frame (3 bolts at CS and 3 bolts at SS).

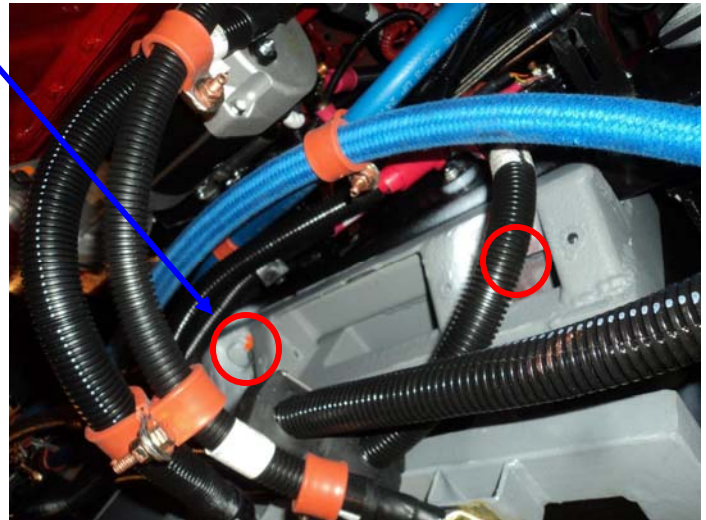

Boston-MBTA: Chassis Inspection



4. Using camera scope

- Use camera scope if excessive amount of water was found inside the following structural components:
 - 3rd crossmember
 - 5th crossmember
 - 11th crossmember
 - 12th crossmember
- Push the scope into the structure through the drain hole and inspect the condition of the interior surfaces.



- Record findings

Boston-MBTA: Chassis Inspection



5. Using the ultrasound thickness tester

- Use the ultrasound tester at the locations marked with  to determine the wall thickness of the steel tubes:

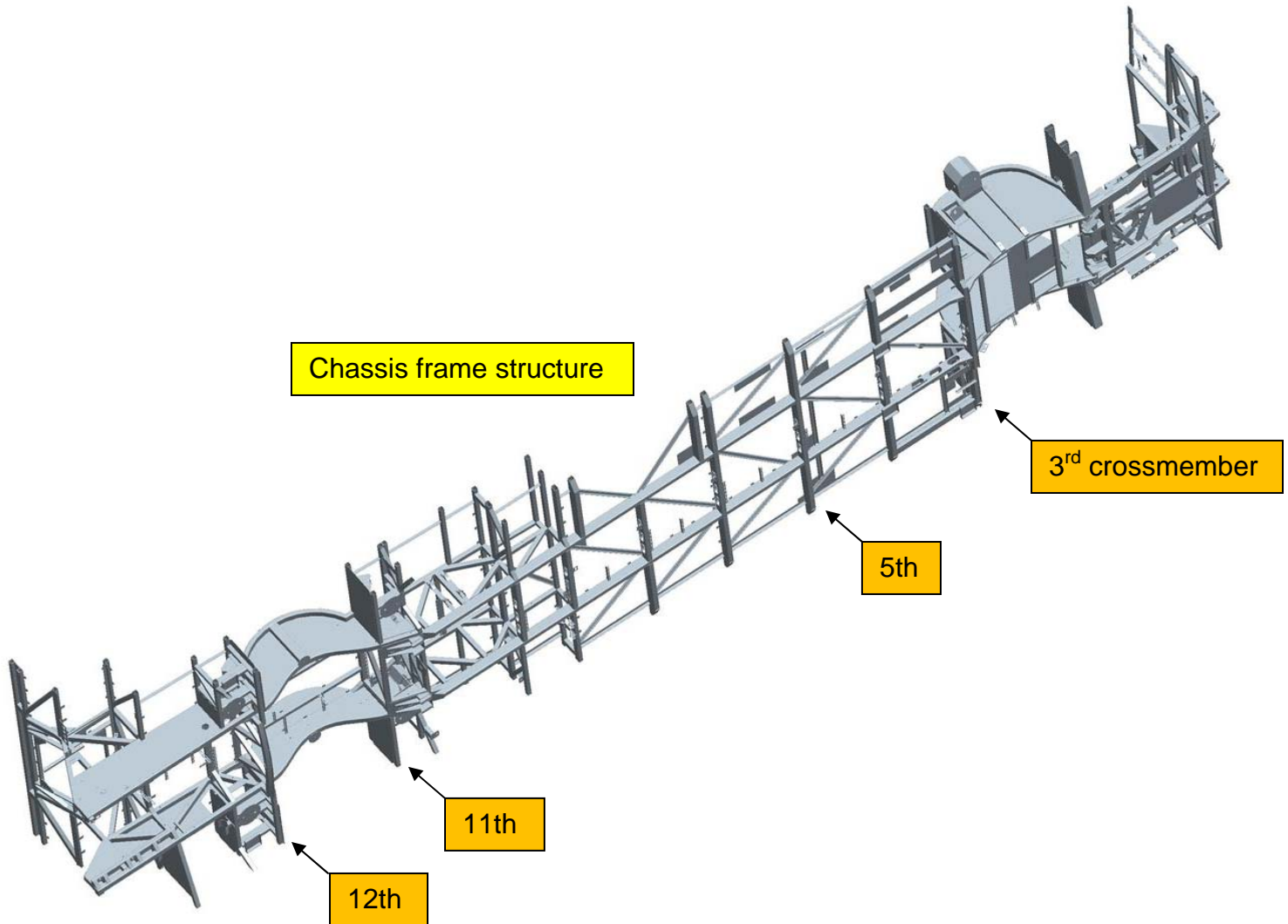

Boston-MBTA: Chassis Inspection



The -s below show where ultrasound measurements must be taken at the front section of the chassis.

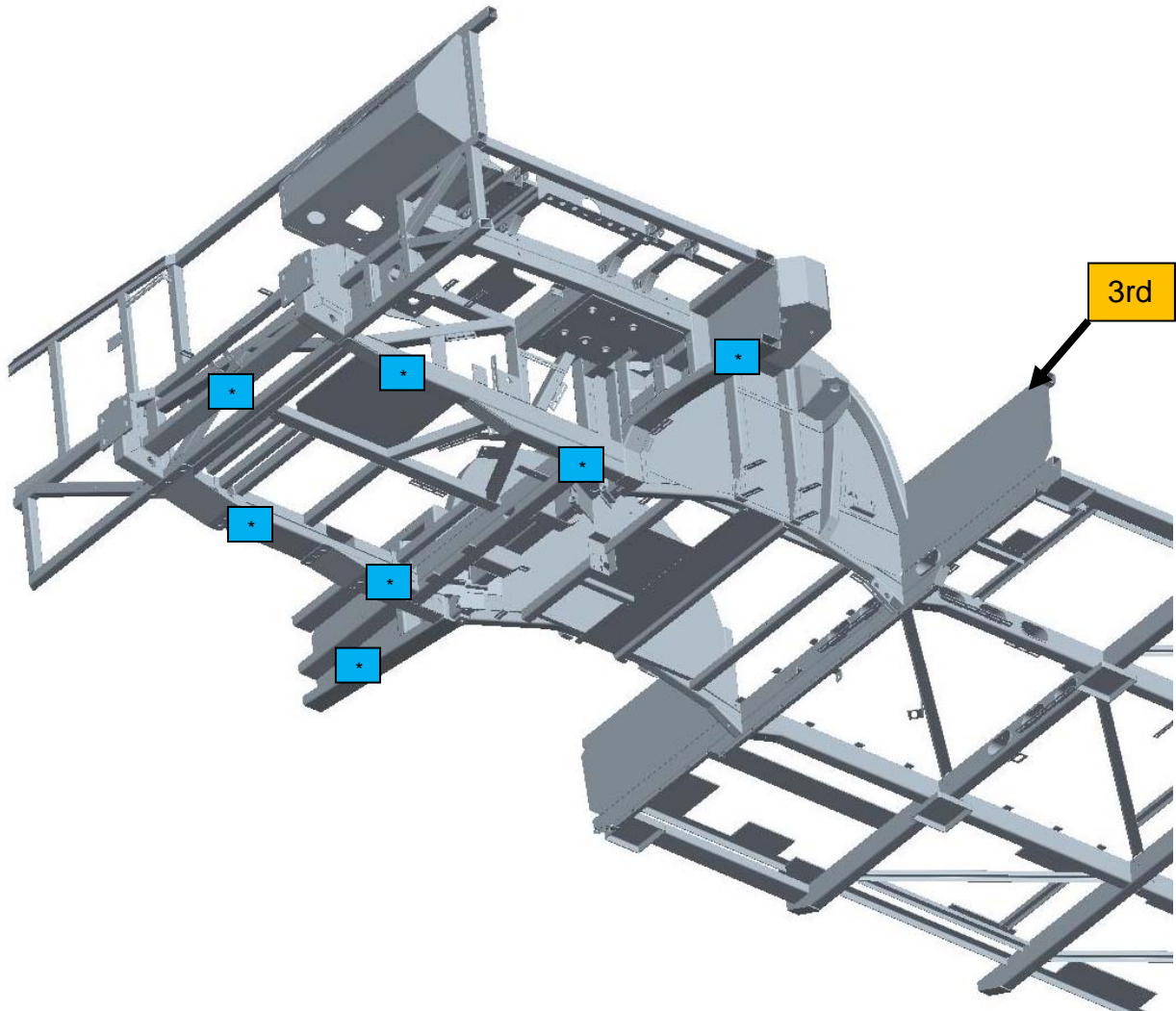

Boston-MBTA: Chassis Inspection



The *s show where ultrasound measurements must be taken at the center section of the chassis.

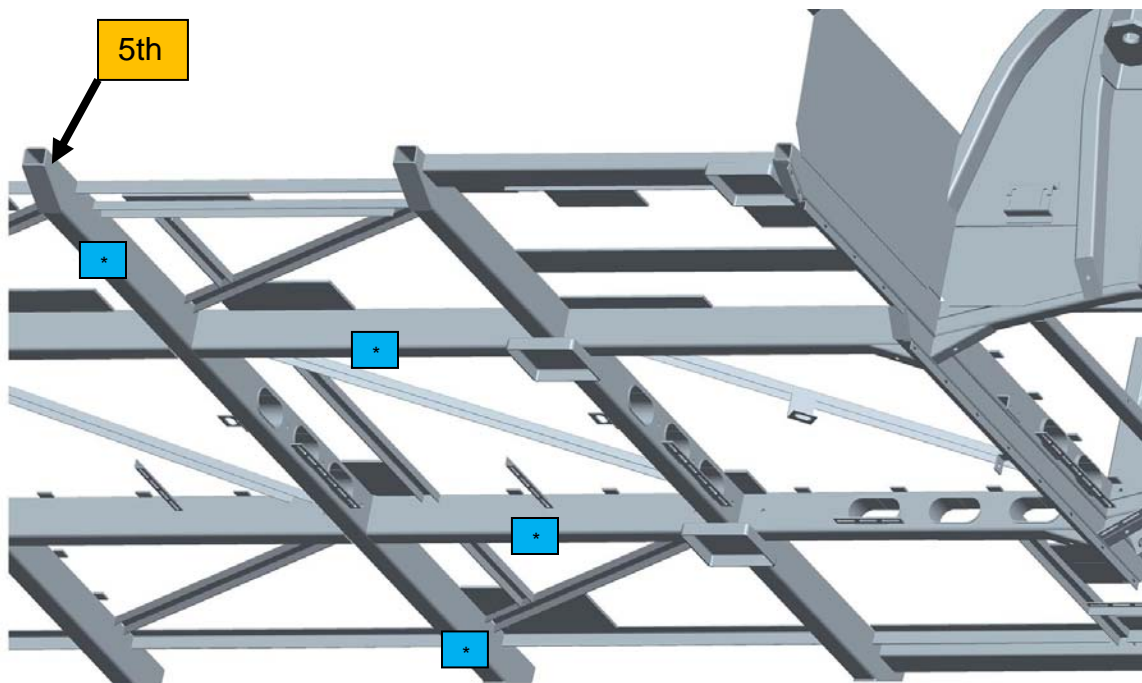
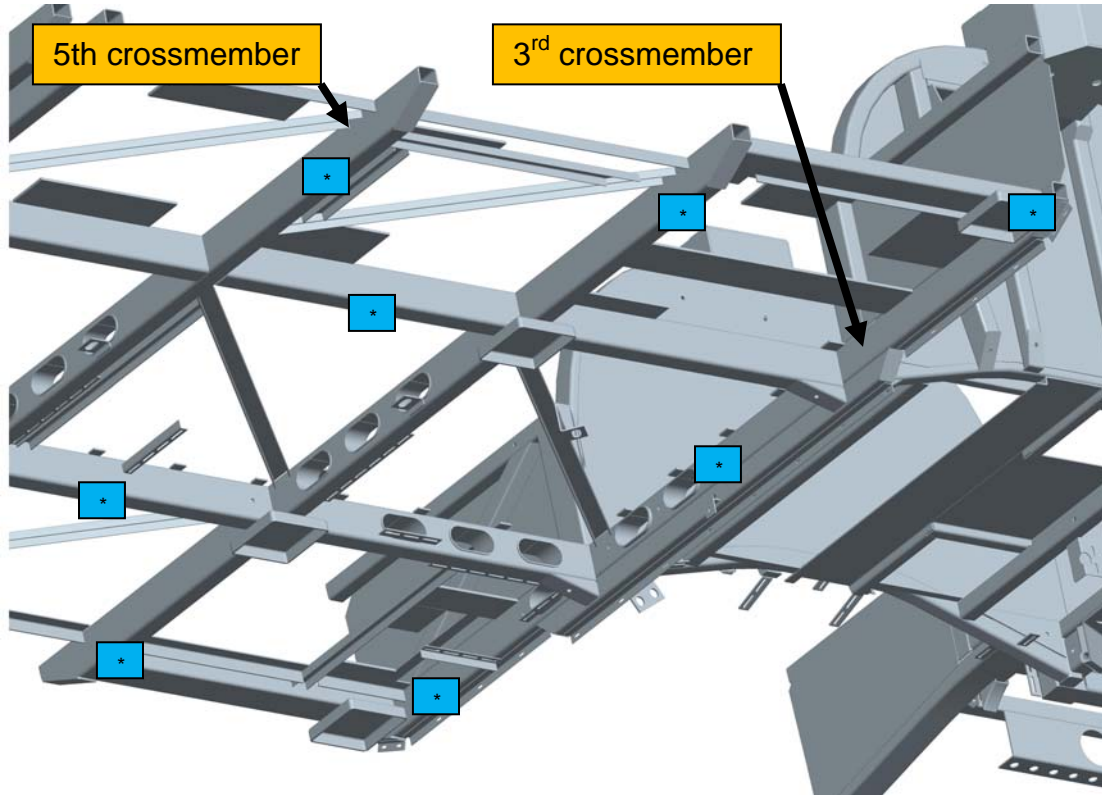

Boston-MBTA: Chassis Inspection



The blue -s show where ultrasound measurements must be taken at the rear section of the chassis (both the curb side and street side).

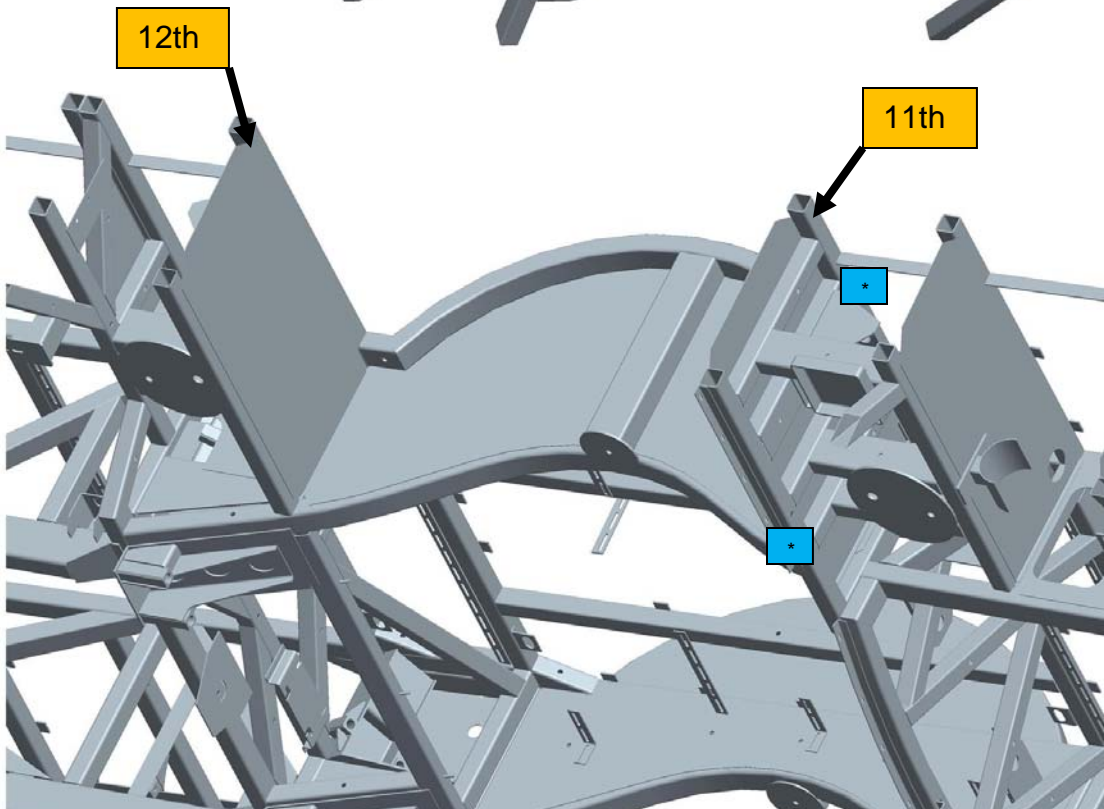
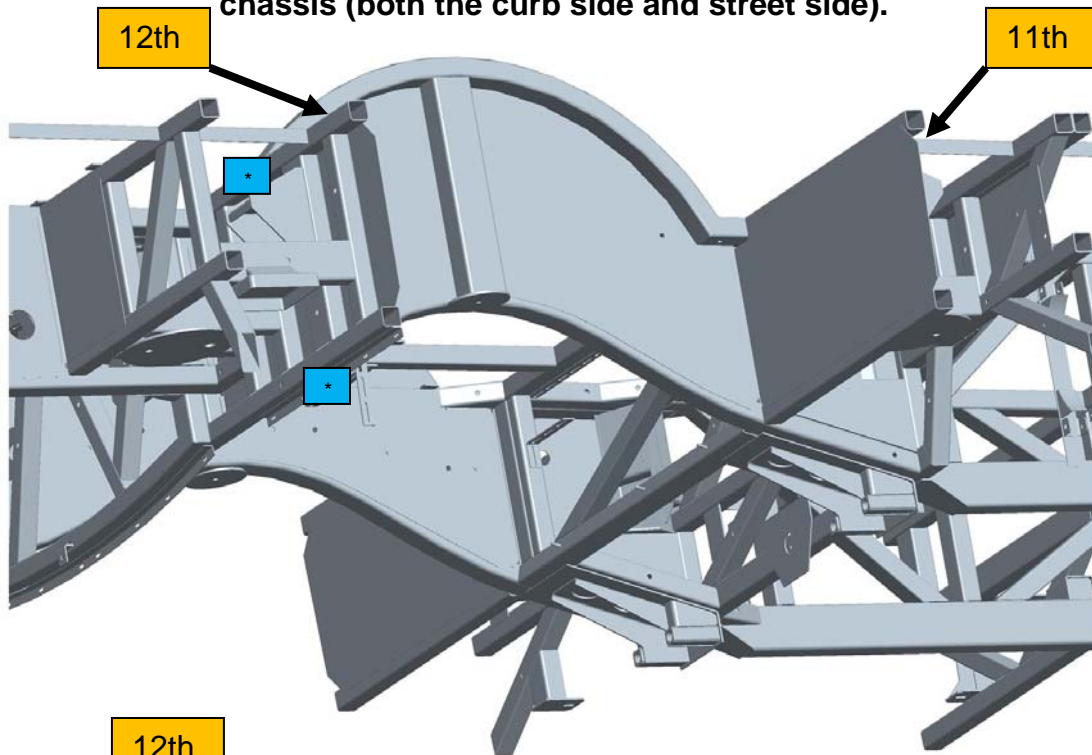

Boston-MBTA: Chassis Inspection



6. Check and drill drain holes according to the pictures below

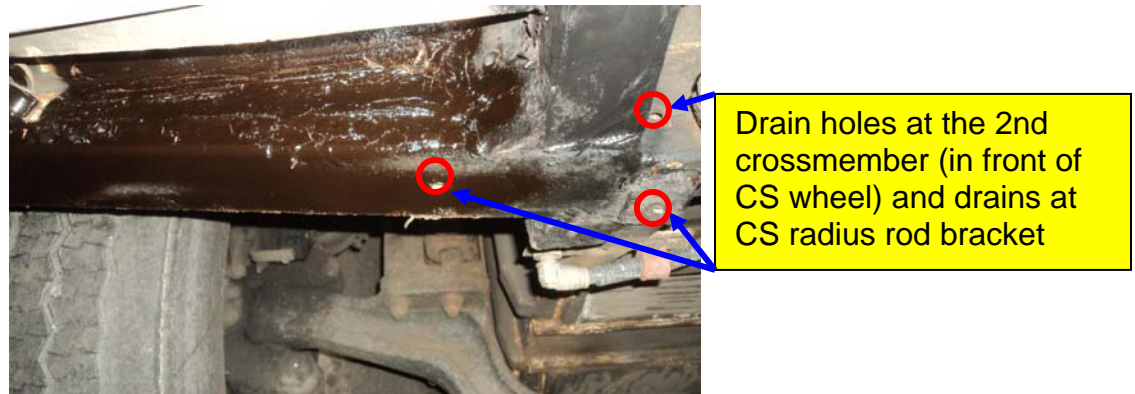
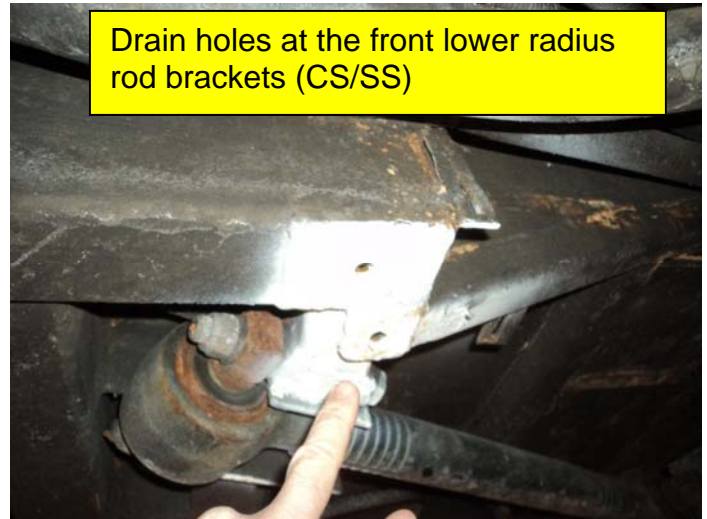
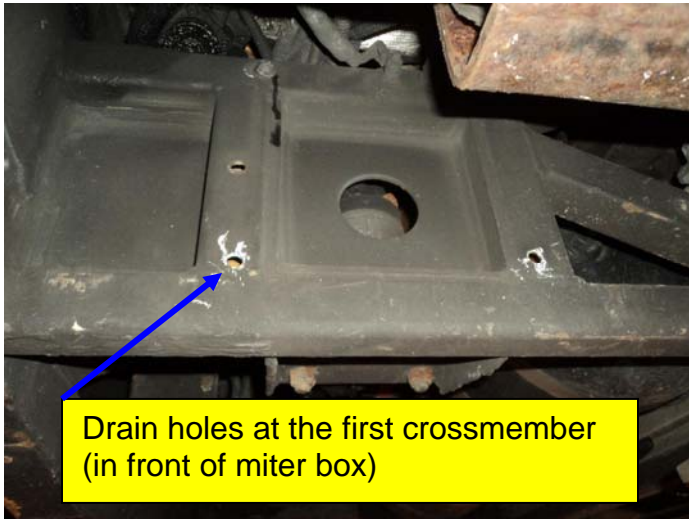

Boston-MBTA: Chassis Inspection



Drain holes along both sides of the bus (bottom of the side walls)

Drain holes at the bottom of the rear side wall columns (CS/SS)

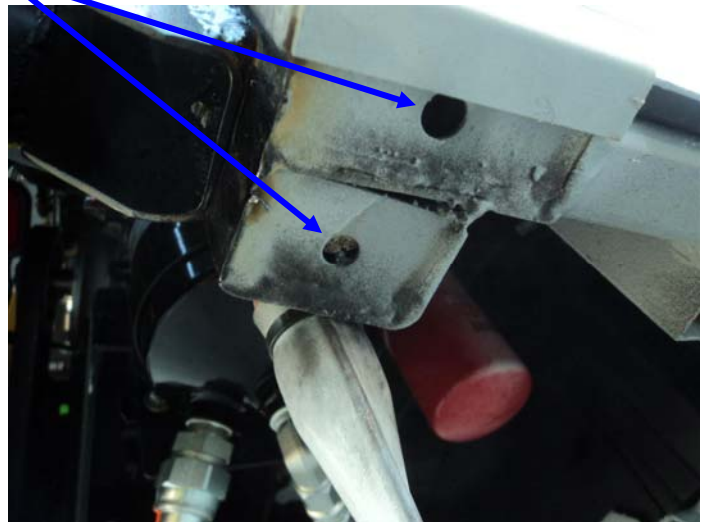

Drain holes on the crossmembers in front of and behind the rear (B) axle:



Drill 3/8" size holes through the bottom and top surfaces of the horizontal tubes underneath the vertical tubes

Boston-MBTA: Chassis Inspection



Final documentation:

7. Record bus number, date of inspection and name of technician who completed the inspection.