



## SRS Indicator Is On With DTC 31-2x and or 32-2x

### SYMPTOM

The SRS indicator is on, and DTC 31-2x (Increased Resistance in Driver's Side Airbag Inflator) or DTC 32-2x (Increased Resistance in Front Passenger's Side Airbag Inflator) is stored.

NOTE: The "x" digit at the end of each DTC can be any one of these: 0 through 9, or A through F.

### POSSIBLE CAUSE

The SRS coupler, located under the front seats for the left and right side air bags, are exposed to movement, and when combined with low crimp strength, can cause the terminals to loosen and have poor connection.

### CORRECTIVE ACTION

Replace the SRS center harness.

### PARTS INFORMATION

SRS Center Harness: P/N 77962-STK-A01

### WARRANTY CLAIM INFORMATION

The normal warranty applies.

Operation Number: 7521A9

Flat Rate Time: 2.8 hours

Failed Part: P/N 77962-STK-A01

Defect Code: 03217

Symptom Code: 03214

Skill Level: Repair Technician

### REPAIR PROCEDURE

The following service manual procedures have been used in full or in part within the service bulletin. For more detail on these procedures, and torque specifications for some components, refer to the appropriate service manual, or view them online.

- Front Seat Removal/Installation
- Battery Terminal Disconnection and Reconnection
- Rear Seat Removal/Installation
- Interior Trim Removal/Installation – Rear Door Sill Area
- Interior Trim Removal/Installation – Front Door Sill Area
- Interior Trim Removal/Installation – B-Pillar upper/Lower Trim

1. Remove both front seats.
2. Remove the front door sill trim from both sides.
3. Remove the rear seat cushion.
4. Remove the rear door sill trim from both sides.
5. Remove the two clips located on the driver's and passenger's side that attach the front carpet to the rear carpet.

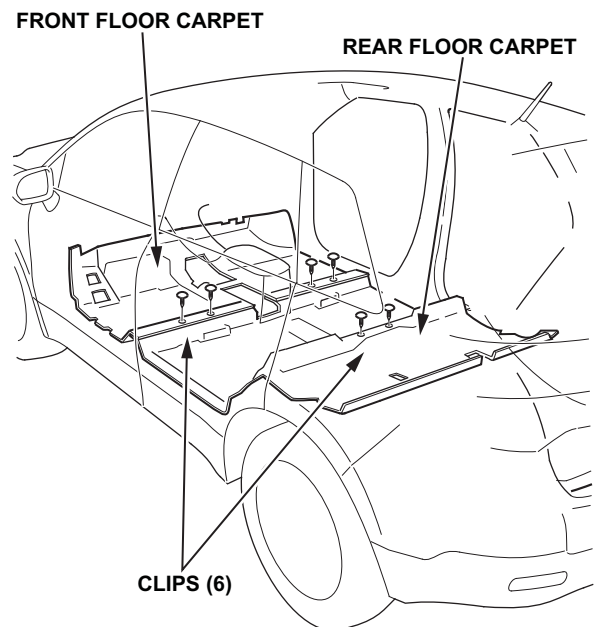

- Pull up the sections of the rear carpet flaps, located behind the driver and passenger seat area, and use a bungee cord to tie the rear carpet flaps together as shown.

Fold the rear carpet up over the center console.

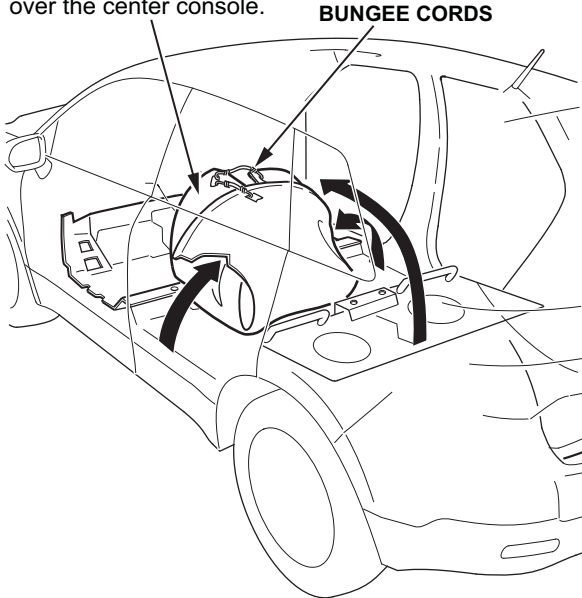

- Remove the screw and the clip, then pull out the driver's console cover toward you to detach the clips. Release the fastener and the hooks, then remove the cover.

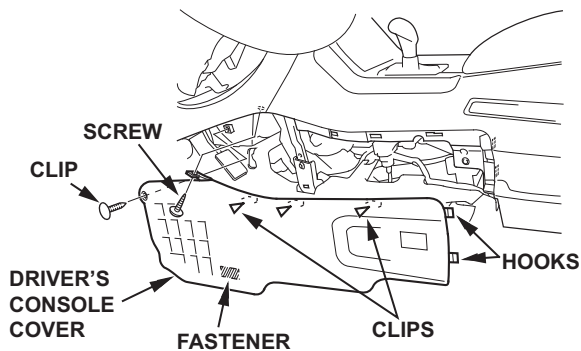

- Detach the clips and hooks by pulling the passenger's console cover out, and pull it backward to release the pin from the passenger's dashboard undercover, then remove it.

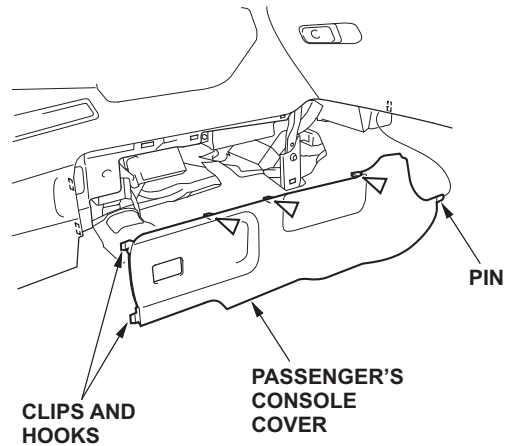

- Fold both rear seats down.
- Remove the cargo area cover and the floor. Lift up the cargo area lid to detach the clips.

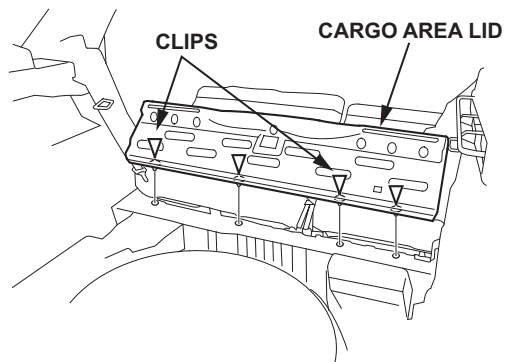

- Remove the cargo opening seal along the bottom. Then remove the cargo trim panel.

12. Remove the cargo area side trim panel. Repeat on the opposite side.

NOTE: The cargo light 2P connector must be disconnected before removing the left cargo side trim panel.

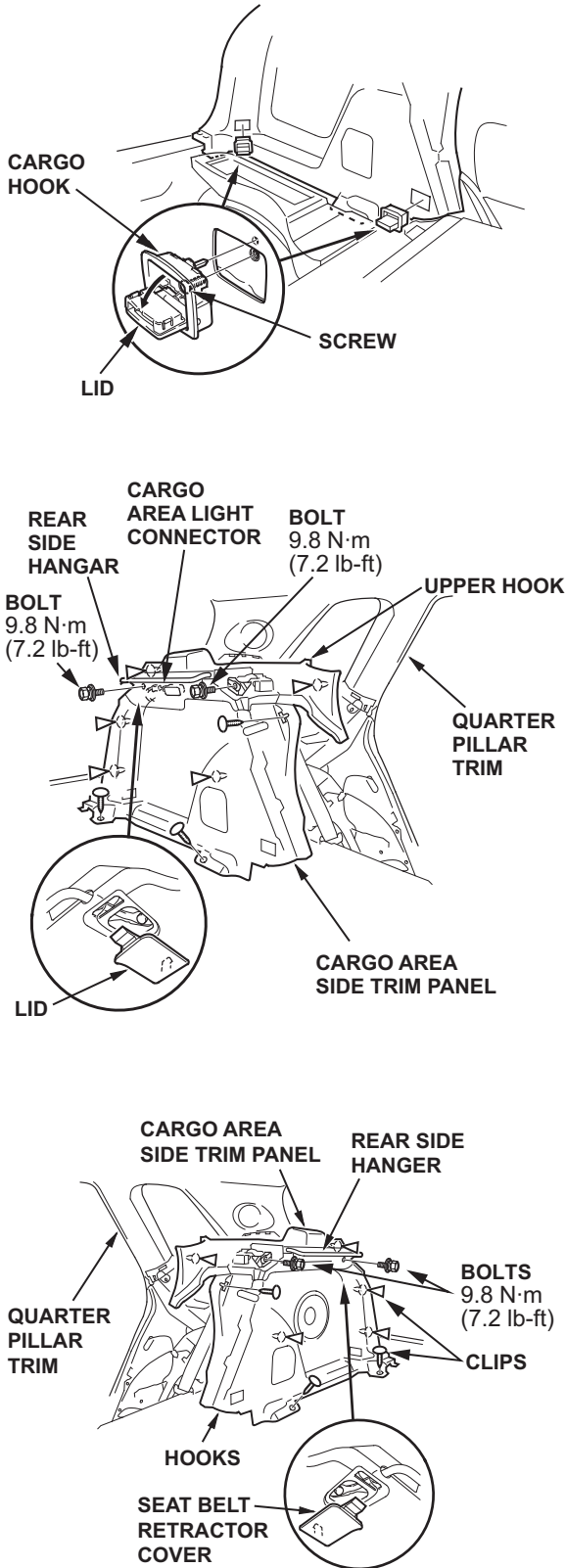

13. Disconnect the left side curtain airbag igniter 2P connector, located behind the rear seat belt retractor. Then, continue removing the harness clips from the holes in the body up to the left side rear wheel arch.

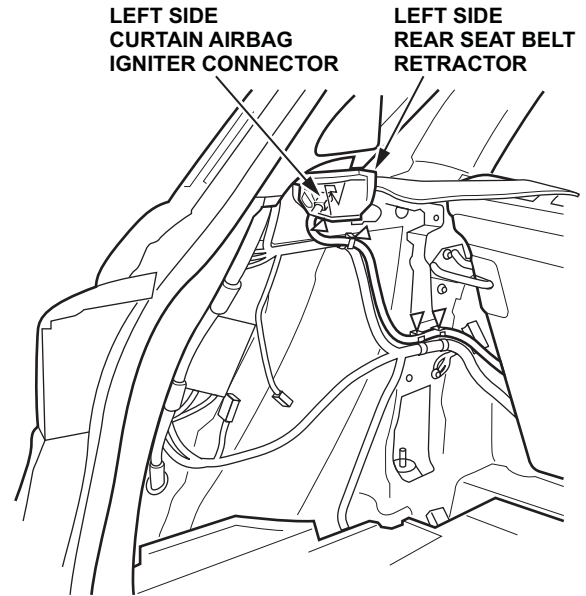

14. Disconnect the right side curtain airbag igniter 2P connector located behind the right side rear seat belt retractor. Then, continue removing the harness clips from the holes in the body up to the right side rear wheel arch.

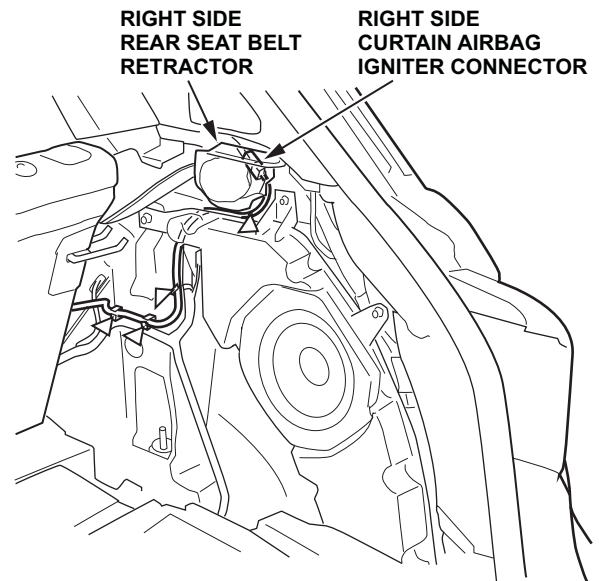

15. Disconnect the left side rear door impact sensor (second) connector at the left rear wheel arch. Then, continue removing the harness clips from the holes in the body down the rear wheel arch, working towards the left side rear floor area.

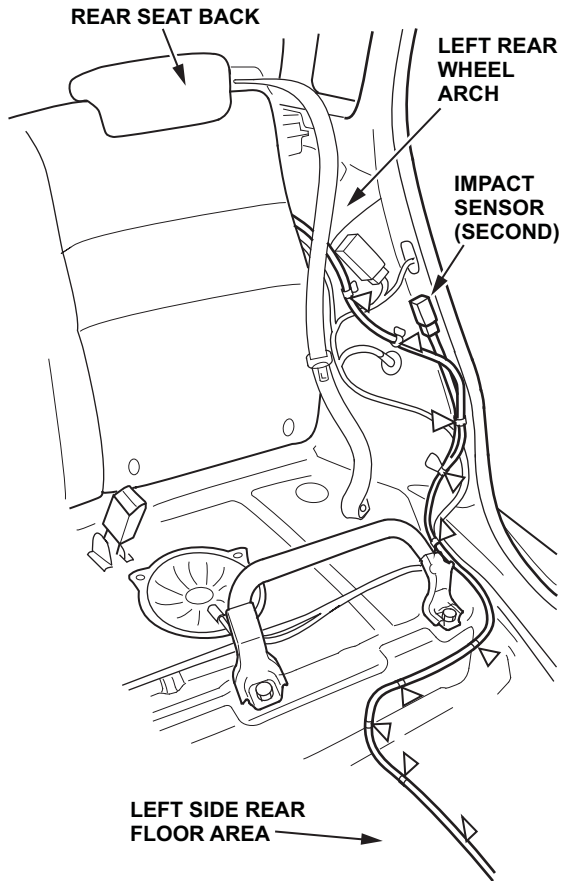

16. Continue removing the harness clips, working toward the driver's seat location.

17. Disconnect G551 (5 wire ground). Then, continue removing the harness clips, working towards the B-pillar.

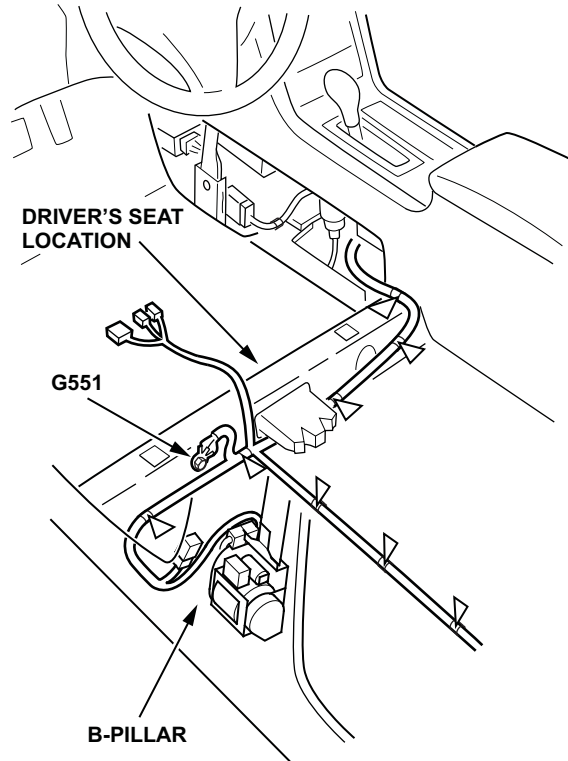

18. Disconnect the left side impact sensor (first) connector and the driver's seat belt tensioner connector from the B-pillar.

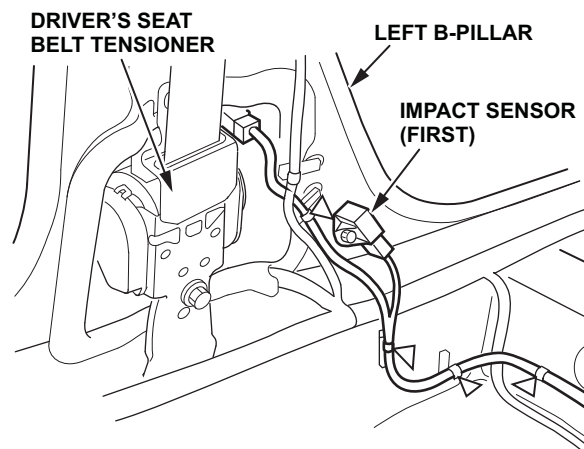

19. Disconnect C405 (white coupler) from the dashboard harness.

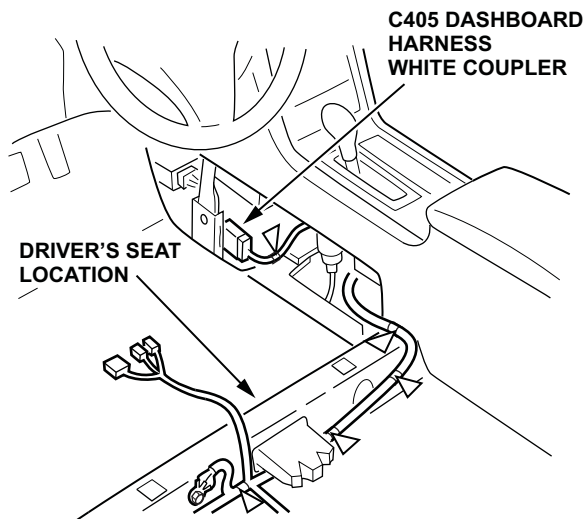

20. Move to the right rear wheel arch area of the vehicle and disconnect the right side rear door impact sensor (second) arch. Continue removing the harness clips from the holes in the body down the rear wheel arch working towards the rear floor area.

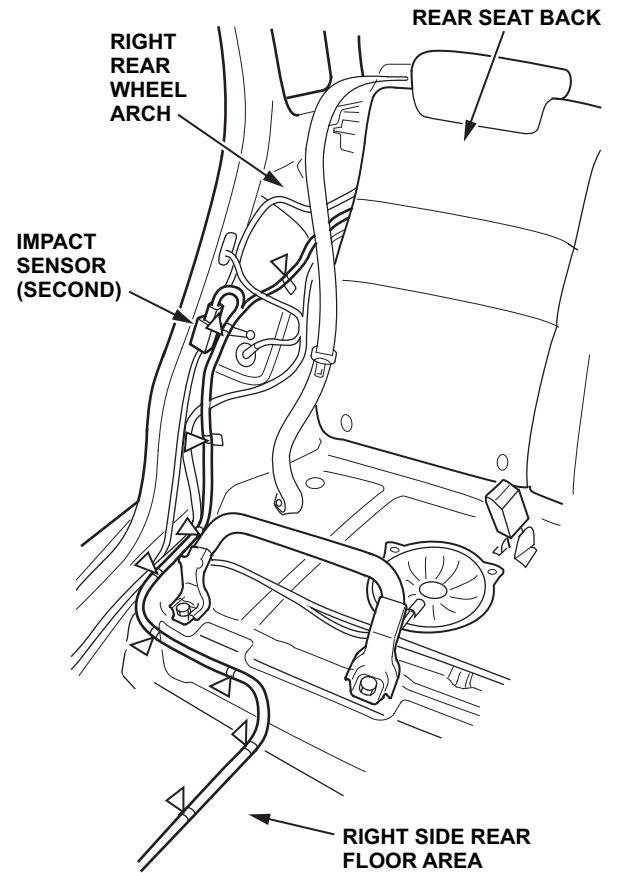

21. Continue removing the harness clips, working toward the passengers front seat location.

22. Disconnect G552 (3 wire ground) and roll rate sensor connector. Then continue removing the harness clips working toward the B-pillar.

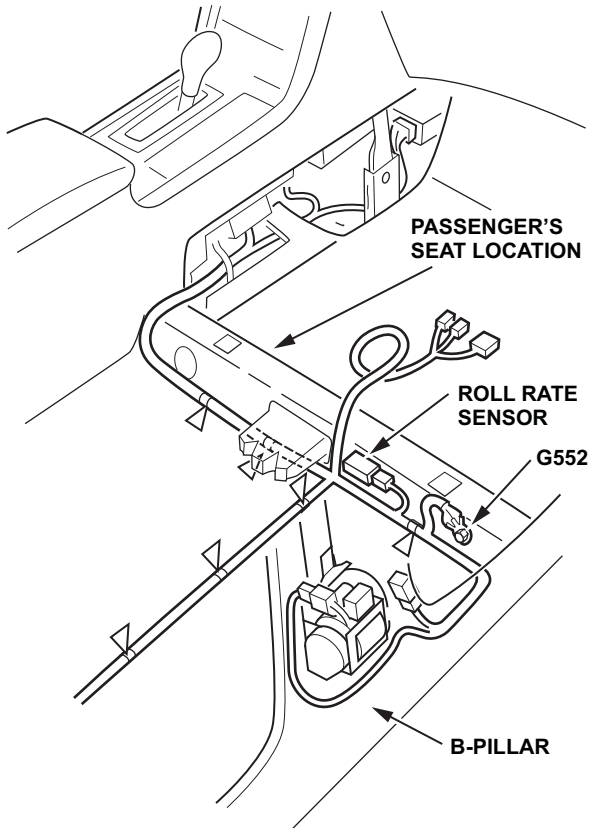

23. Disconnect the right side impact sensor (first) and front passenger's seat belt tensioner connectors from the B-pillar.

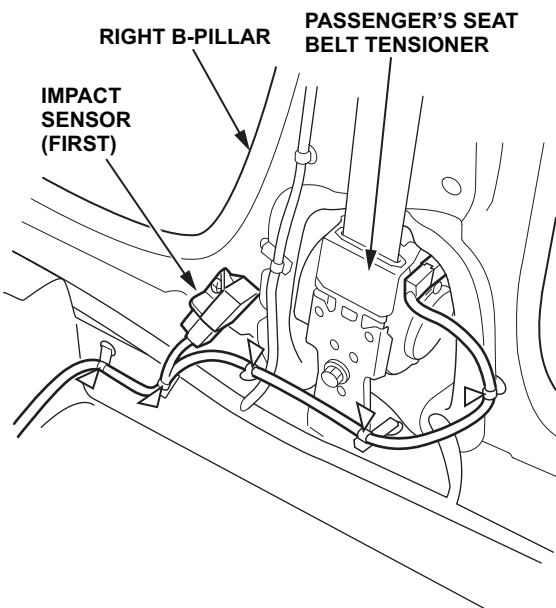

24. Disconnect the HFL unit connector and the dashboard harness clip from the console bracket to help remove the SRS center harness.

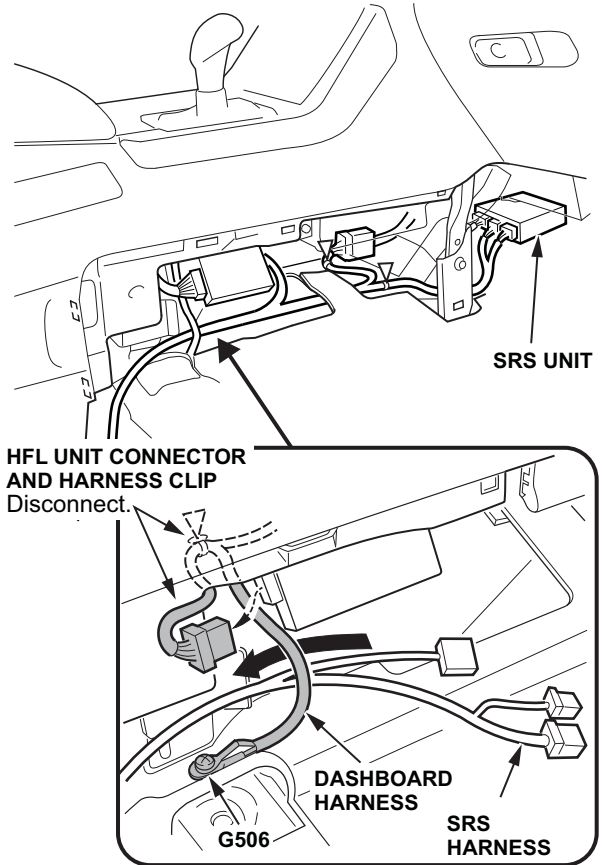

25. Disconnect both connectors from the SRS unit.

26. Remove the SRS center harness from the vehicle.

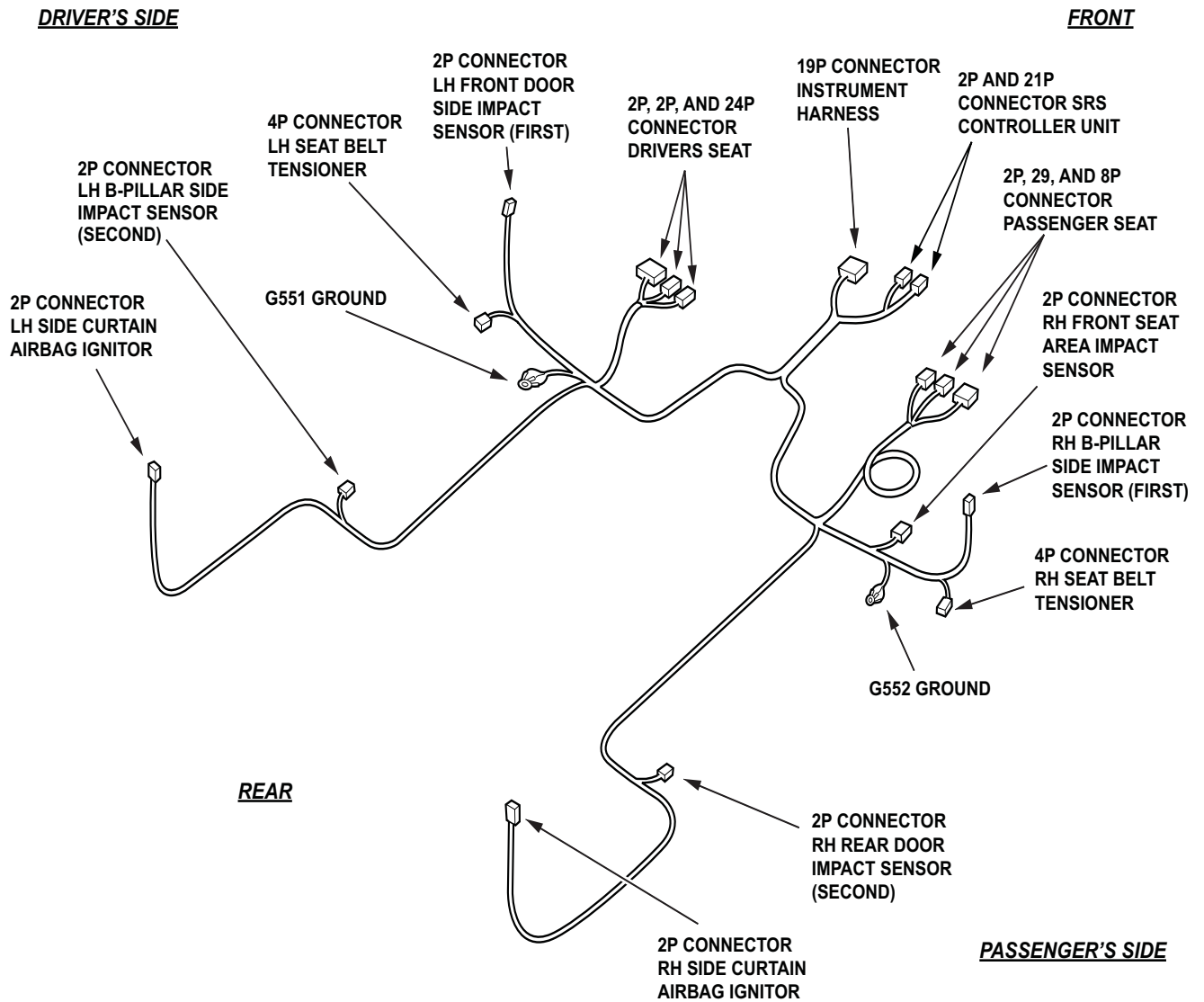

27. Install the new SRS harness: Start at the SRS unit, and work your way back towards the rear of the vehicle.
28. Route both SRS CU yellow couplers and the C405 white coupler under the dashboard harness leading to G506 on the right side of the center console. Reconnect the HFL CU coupler and dashboard harness clip to the console bracket.

**HFL UNIT CONNECTOR AND HARNESS CLIP**  
Disconnect.

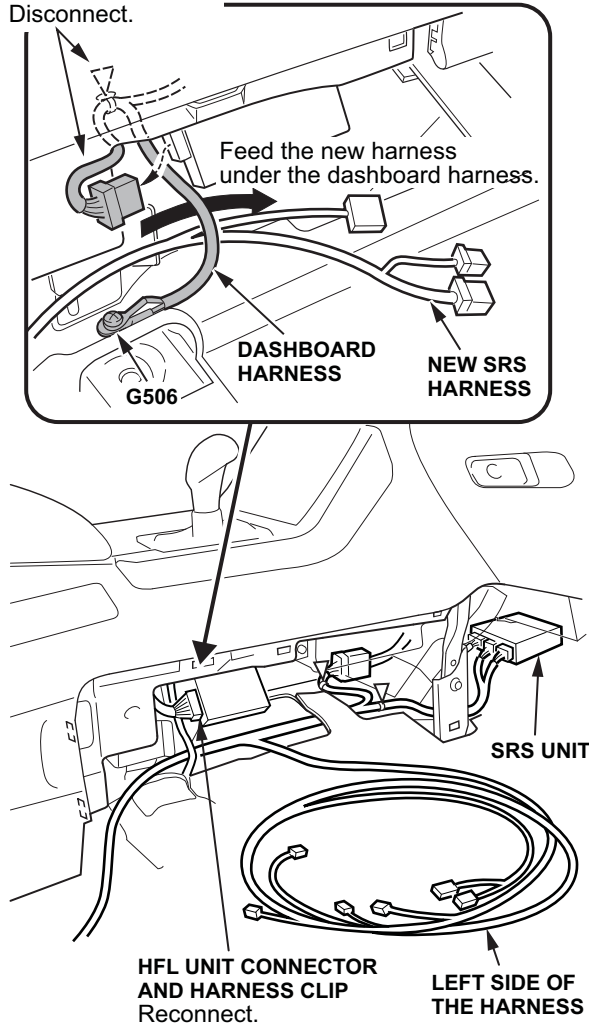

29. Route the left side of the harness (containing the 5 wire ground, G551) through the passenger side of the console and through to the left side of the vehicle.

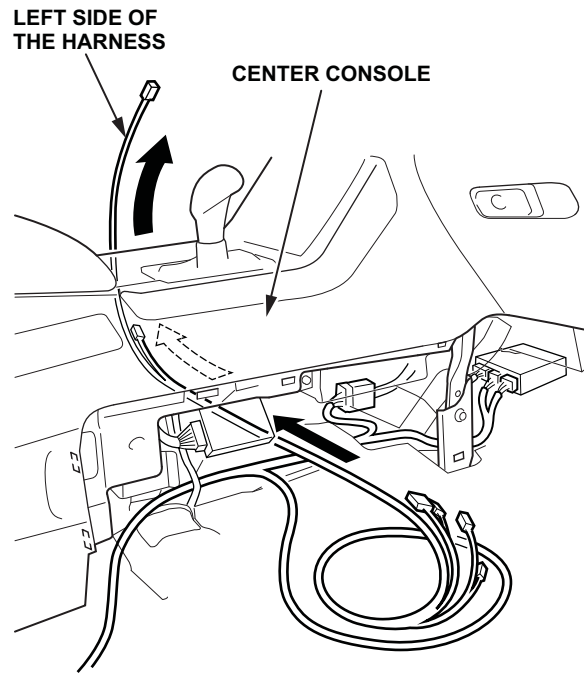

30. Connect both yellow connectors to the SRS unit (from the passenger's side).



31. Connect white connector C405 to the dashboard harness (driver's side). Then continue on the driver's side securing the harness clips into the holes in the body, working back towards the B-pillar, and secure G551 ground.

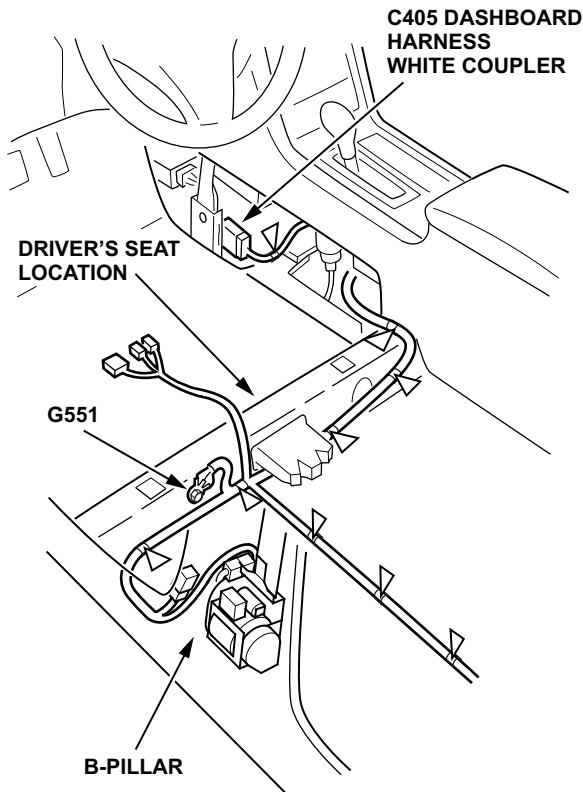

32. Secure the harness clips towards the B-pillar, connect the left side impact sensor (first) and driver's seat belt tensioner.

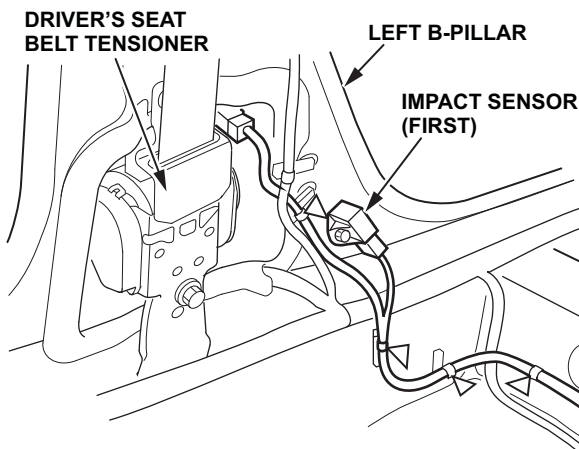

33. Work towards the left side rear wheel arch behind the B-pillar securing the harness clips along the way. White tape on the harness is a marker that there is a corresponding clip to the body. Connect the left side rear door impact sensor (second).

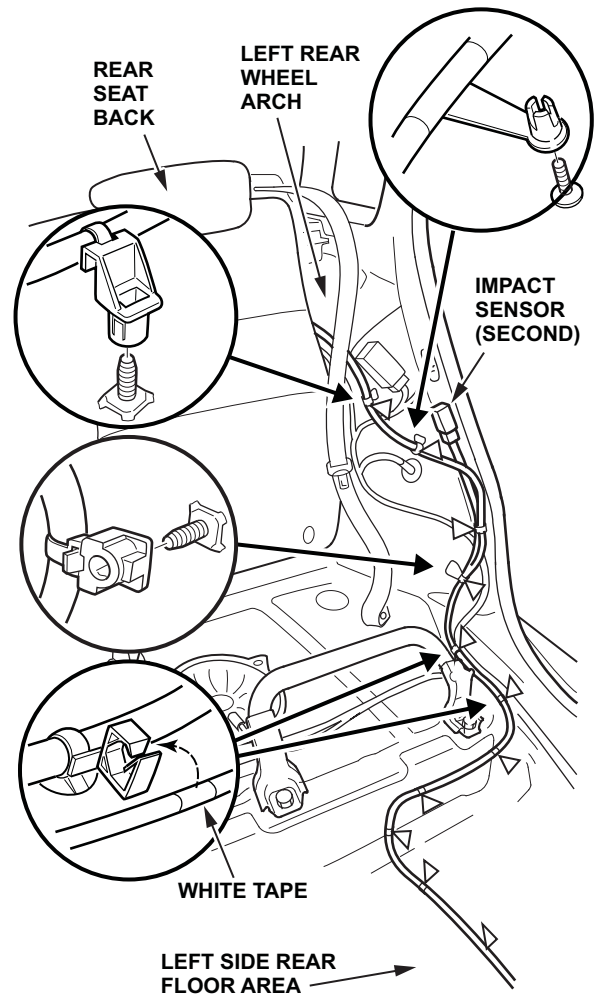

34. Begin working on the passenger front floor area, installing the harness in the passenger's front side area securing the harness clips into the holes in the body. Start at the front and work towards the B-pillar. Secure ground G552, and connect the roll rate sensor.

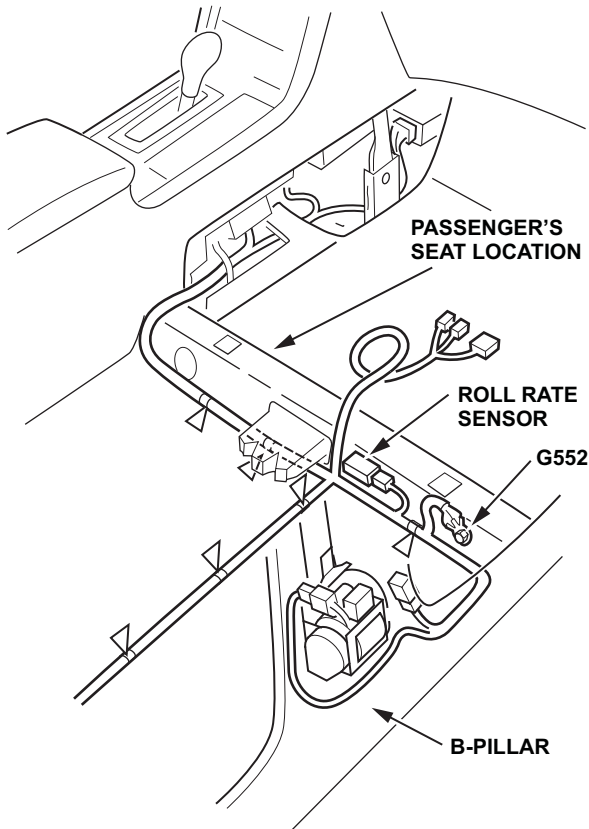

35. Secure the harness clips as you work towards the B-pillar. Then, connect the right side impact sensor (first), and the front passenger's seat belt tensioner.

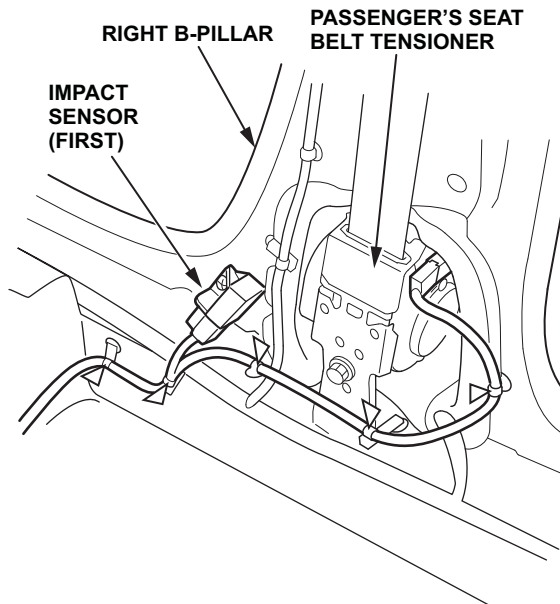

36. Continue working towards the right side wheel arch behind the B-pillar securing the harness clips along the way. White tape on the harness is a marker that there is a corresponding clip to the body. Connect the right side rear door impact sensor (second).

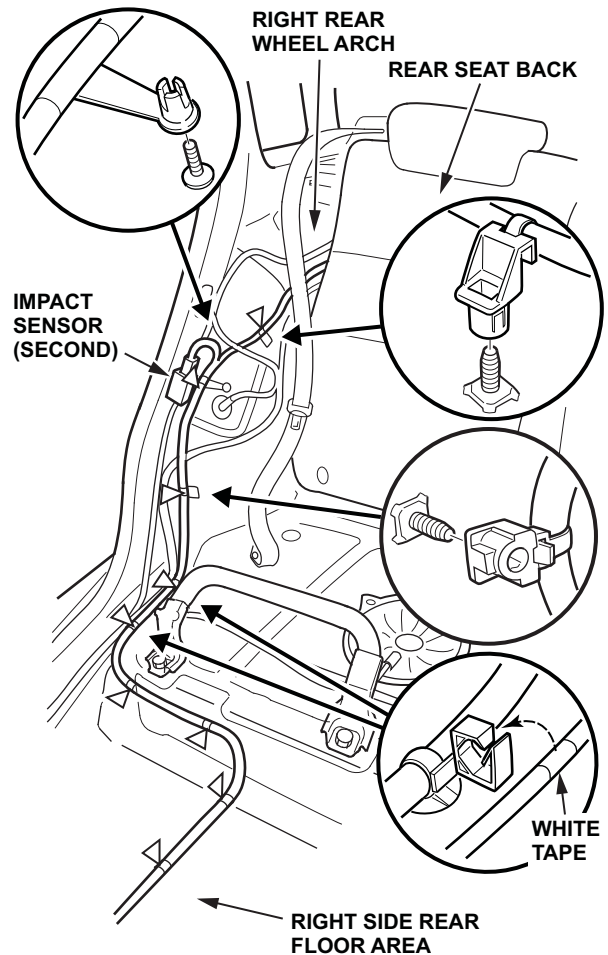

37. Work towards the C-pillar by reattaching the harness clips into the body holes. Connect the right side curtain airbag igniter.

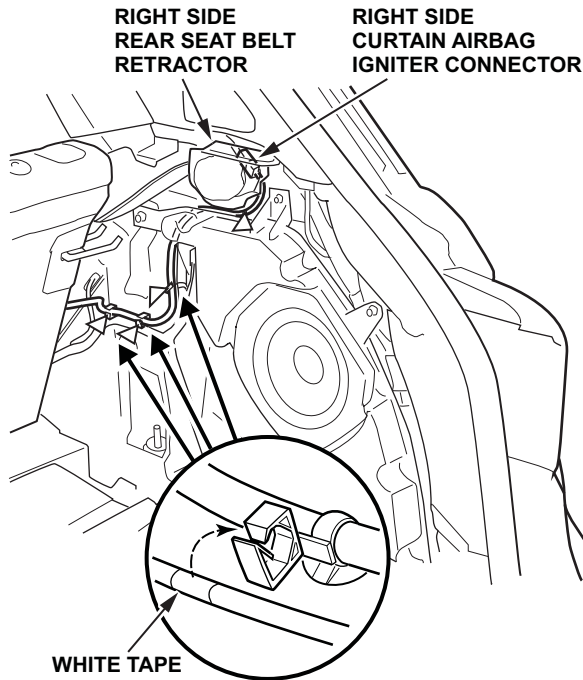

38. Finish securing the harness clips into the body on the left cargo area side. Connect the left side curtain airbag igniter.

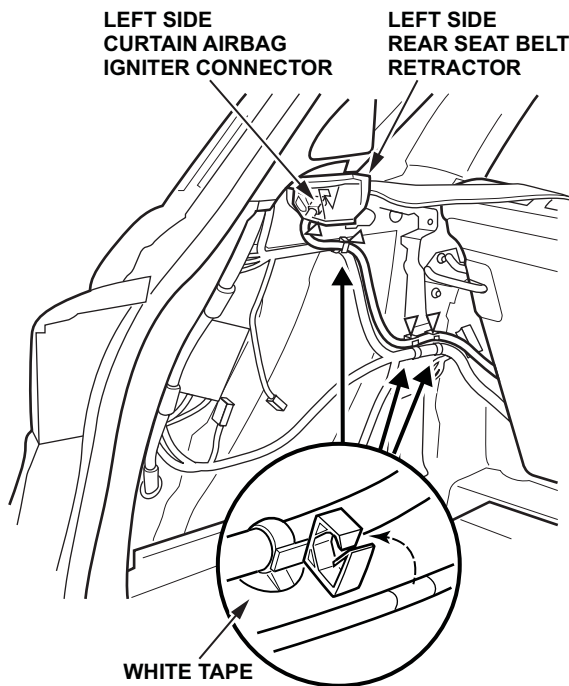

39. Reinstall the cargo area side trim panels, the cargo opening seal, the cargo area cover, and the cargo area floor.

NOTE: Connect the cargo light 2P coupler prior to left side cargo side trim panel installation.

40. Reinstall the console covers.
41. Remove the bungee cord from the carpet and reinstall the flaps into place. Then attach the carpet flaps.
42. Reinstall the B-pillar lower trim. Thread the seat belt back into the seat belt guide through the slit, and reinstall the seat side bolsters and torque the bolts to **9.8 N•m (7.2 lb-ft)**.
43. Reinstall the rear door opening seals, the rear door sill trim, and the rear outer trim.
44. Reinstall the rear seat bottom cushions.
45. Reinstall the front door opening seals, the front door sill trim, and the front side outer trim.
46. Reinstall the front seats, connect all connectors, then torque the seat bolts to **34 N•m (25 lb-ft)**.
47. Reinstall the track end covers, reinstall the seat belt lower anchor bolts and torque the bolts to **32 N•m (24 lb-ft)**.
48. Reinstall the head restraints.
49. Reinstall the floor mats.