

**IMPORTANT INFORMATION**

Please inform and provide a copy of this document to every person in your dealership with campaign-related responsibilities, including Service, Parts and Accounting personnel. By law, dealers must correct, prior to delivery for sale or lease, any vehicle that fails to comply with an applicable Federal Motor Vehicle Safety Standard or that contains a defect relating to motor vehicle safety. **If you have questions regarding this or any other campaign, please contact Warranty.**



# Service Action

**Code: 64C9**

**Subject: 2012 – 2013 MY Volkswagen Beetle  
Front Window Motors**

**January 09, 2013**

## Problem Description

Some Beetle customers have reported problems with the operation of the front windows in their vehicle. We have identified the window motors installed in production as the cause of these problems.

## Corrective Action

Install improved front window motors.

## VINs & Production Dates of Affected Vehicles

### **NOTE:**

- *ElsaWeb is the only valid campaign inquiry/verification source. Check ElsaWeb on the day the campaign work will be performed to verify vehicle eligibility for the repair in order to receive claim payment consideration. Campaign status must show "open".*
- *If this repair appears to have already been performed on the vehicle but the code still shows open in ElsaWeb, contact Warranty before proceeding further. Another dealer may have recently performed this repair but not yet entered a claim for it in the system.*
- *ElsaWeb may also show additional open action(s); if so, inform your customer - this work can be done while the vehicle is in for this campaign.*
- *Contact Warranty if you have any questions.*

### **U.S.A.**

3VW\_\_ \_AT\_CM500171 – 3VW\_\_ \_AT\_DM621134  
Production dates: February 17, 2011 – August 29, 2012

### **Canada**

3VW\_\_ \_AT\_CM600127 – 3VW\_\_ \_AT\_DM616908  
Production dates: May 30, 2011 – August 31, 2012

**NOTE:** The VIN range is a general range of vehicles that may be included in the Campaign. Not every vehicle within the VIN range may be included since it may depend on the production date, transmission or engine build date. Always verify ElsaWeb for campaign eligibility on a vehicle.

## Allocation Report of Affected Vehicles

Electronic allocation lists will be posted under My Dealership Reports on [www.vwclub.com](http://www.vwclub.com) on or about January 09, 2013. A list will not be posted for dealers who have no affected vehicles.

## Parts Information and Allocation

- Parts allocation will take place prior to customer notification.
- The Targeted Allocation program will be used in support of this campaign. Dealers who have not yet completed the targeted allocation web-based training module

(course number 449324) on this new program should do so as soon as possible.

- Please refer to the dealer letter and Campaign Data Sheet for information regarding the Completion Factor/Replacement Rate for your targeted allocation calculations.
- If additional parts are required for critical cases, please contact the Parts Specialists at 800-767-6552.

## Owner Notification Mailing

Customer notification will take place on or about January 09, 2013. Sample copies of the owner letters are enclosed.

## Campaign Expiration Date

- This action expires on January 31, 2015. Dealers should keep this expiration date in mind when scheduling customers for this action.
- Vehicles inspected/repared under this action must have this service completed on or before January 31, 2015 to be eligible for payment.
- Inspections/repairs performed after January 31, 2015 will not be eligible for payment under this action.

## Campaign Completion Labeling Guidelines

Vehicles repaired under this action must be identified with a campaign completion label (CAMP 010 000). Labels can be ordered at no cost online via the Compliance Label Ordering portal at [www.vwclub.com](http://www.vwclub.com).

## Claim Entry Procedure

### **U.S. Dealers Only:**

- For inventory vehicles repaired prior to January 9, 2013, refer to UPDATE 64C7 claiming instructions found in ServiceNet. **These claims must be entered on or before January 30, 2013 to be eligible for payment.**
- Vehicles repaired on or after January 9, 2013 **must** use the claiming instructions found in this circular.

### **ALL Dealers:**

- Immediately upon completion of the repair work, enter the Applicable Criteria ID and Repair Operation from the following chart. The Applicable Criteria ID is shown in ElsaWeb.
- Claims will only be paid for vehicles that show this campaign open in ElsaWeb **on the day of the repair.**
- To help ensure prompt and proper payment, attach the screen print to the repair order.

# Saga Claim Entry Procedure

Check ElsaWeb to determine if this campaign is open.

Service No.: 64C9  
Damage Code: 0099

## Parts Manufacturer

Removed part: Use vendor code YUZ

## Claim Type

Sold vehicle = 7 10

Unsold vehicle = 7 90

## Accounting Instructions

### Criteria I.D. 01

Inspect driver & passenger side window motors. Updated motors present on **BOTH SIDES**. No further work required.

Repair operation: 0183 00 99 20 TU

-- OR --

Inspect driver & passenger side window motors. Install two new window motors.

Repair operation: 6454 56 99 100 TU

**This note applies to U.S. Dealers Only:  
Important information for inventory vehicles repaired  
prior to January 9, 2013 under UPDATE 64C7**

**For inventory vehicles repaired prior to January 9, 2013,  
refer to the UPDATE 64C7 claiming instructions found in  
ServiceNet. *These claims must be entered on or before  
January 30, 2013 to be eligible for payment.***

Quantity	Part Number	Part Description
1	6R0 959 801AP Z01	Driver side Window Motor
1	6R0 959 802BC Z01	Passenger Side Window Motor
.01	D 195 800 A1	Loctite® Formula 480

## Loaner Vehicle Claiming Information – USA and Canada

### Outside material:

Description	Amount
Loaner	\$35 (maximum)

***There is NO reimbursement for vehicle wash!***

### If customer refused repairs

Fax the repair order to the warranty team at (248) 754-4734 (U.S) and (905) 428-4811 (CAN). Provide the VIN, applicable service number, customer information, dealer number and date.

**Subject: Service Action 64C9/W5 – Front Window Motors  
2012-2013 Model Year Volkswagen Beetle**

Dear <CUSTOMER NAME>,

As a valued Volkswagen Beetle customer, your satisfaction is our utmost priority. We are writing to you today about how we intend to address/prevent an issue that some customers have experienced with the front windows on their vehicles.

**What is the issue?** Some Beetle customers have reported problems with the operation of the front windows in their vehicle. We have identified the window motors installed in production as the cause of these problems.

**What will we do?** Your authorized Volkswagen dealer will install improved front window motors on your Beetle at no cost to you. On average, this repair will take about four hours to complete. **Please note that this repair will be available for you free of charge only until January 31, 2015.** After that, any remaining applicable warranty will apply.

**What should you do?** In order to limit any possible inconvenience, please contact your authorized Volkswagen dealer as soon as possible to schedule your repair. This will allow your dealer time to plan ahead and ensure that the required parts are available for your vehicle on your scheduled appointment date.

**Lease vehicles and address changes** If you are the lessor and registered owner of the vehicle identified in this action, please forward this letter immediately via first-class mail to the lessee within ten (10) days of receipt. If you have changed your address or sold the vehicle, please fill out the enclosed prepaid Owner Reply card and mail it to us so we can update our records.

**Can we assist you further?** If you have any questions regarding this repair, please contact us at:

Volkswagen of America, Inc.,  
Attn: Customer CARE (64C9/W5)  
3800 Hamlin Road, Auburn Hills, MI 48326  
1-800-893-5298

We apologize for any inconvenience this matter may cause; however we are taking this action to help ensure your Volkswagen Beetle continues to meet and exceed your expectations. Thank you for driving a Volkswagen!

Sincerely,

Volkswagen Service & Quality

## Customer Letter Example (CANADA)

**Subject: Service Action 64C9/W5 – Front Window Motors  
2012-2013 Model Year Volkswagen Beetle**

Dear <CUSTOMER NAME>,

As a valued Volkswagen Beetle customer, your satisfaction is our utmost priority. We are writing to you today about how we intend to address/prevent an issue that some customers have experienced with the front windows on their vehicles.

**What is the issue?** Some Beetle customers have reported problems with the operation of the front windows in their vehicle. We have identified the window motors installed in production as the cause of these problems.

**What will we do?** Your authorized Volkswagen dealer will install improved front window motors on your Beetle at no cost to you. On average, this repair will take about four hours to complete. **Please note that this repair will be available for you free of charge only until January 31, 2015.** After that, any remaining applicable warranty will apply.

**What should you do?** In order to limit any possible inconvenience, please contact your authorized Volkswagen dealer as soon as possible to schedule your repair. This will allow your dealer time to plan ahead and ensure that the required parts are available for your vehicle on your scheduled appointment date.

**Lease vehicles and address changes** If you are the lessor and registered owner of the vehicle identified in this action, please forward this letter immediately via first-class mail to the lessee within ten (10) days of receipt. If you have changed your address or sold the vehicle, please fill out the enclosed prepaid Owner Reply card and mail it to us so we can update our records.

**Can we assist you further?** If you have any questions regarding this repair, please contact us at:

Volkswagen Canada  
Attn: Customer Relations (64C9/W5)  
PO Box 842, Stn. A  
Windsor, ON N9A 6P2  
1-800-822-8987

We apologize for any inconvenience this matter may cause; however we are taking this action to help ensure your Volkswagen Beetle continues to meet and exceed your expectations. Thank you for driving a Volkswagen!

Sincerely,

Volkswagen Service & Quality

If there are questions regarding the work procedure:

- U.S. dealers, contact Warranty
- Canadian dealers, open an VTA ticket using concern group “Compliance\_Recall Assistance (C)”

### Required Parts:

<u>Quantity</u>	<u>Part Number</u>	<u>Part Description</u>
1	6R0 959 801AP Z01	Window Lifter Motor (Driver’s Side)
1	6R0 959 802BC Z01	Window Lifter Motor (Passenger’s Side)
.01	D 195 800 A1	Loctite® Formula 480
1	CAMP 010 000	Campaign Completion Label

### Important Information Regarding Loctite® 480:

- It is imperative that this item is stored between 2°C and 8°C (consult MSDS for specific details). Storing this item at room temperature can adversely affect product properties.
- Loctite® Formula 480 was specifically selected for this application. **ONLY** Loctite® formula 480 may be used for this repair. Any generic red/blue Loctite® (or equivalent) used for other repairs will not work for this application.
- Each bottle contains enough adhesive to service 250 vehicles.

### Required Tools:



- 3409 – Trim Removal Wedge
- T10383 – Wedges
- VAS 5051 – Vehicle Diagnosis, Testing & Info. System (or equivalent)
- VAG1783 - Torque Wrench, 2-10 Nm (or equivalent)

**Work Procedure:**

 **Tip:**  
If Campaign Completion Label is present, no further work required.

**Section A – Identify Criteria and Check for Open Status**

- Enter the VIN in ElsaWeb and proceed to the “Campaign/Action” screen.

**Section A – Identify Criteria and Check for Open Status**

 **Tip:** On the date of repair, print this screen and keep a copy with the repair order.

- Enter the VIN in ElsaWeb and proceed to the “Campaign/Action” screen.

⇐ Ensure that the Status is “Open” <arrow 2>.

⇐ Note the Applicable Criteria ID <arrow 1> for use in determining the correct work to be done and associated parts.

Applicable Criteria ID (s)	Campaign/Action Status
01	Open

EXAMPLE

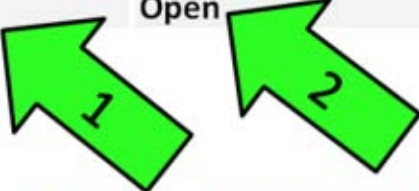

**Continue to Section B**

**Section B – Check for Previous Repair**

- Connect the VAS tester to the vehicle and turn the ignition on (15 power).
- Start “Vehicle Self Diagnosis”.
- Select “09-Electronic central electronics”.
- Select “002-Identification”.
- Select “002.01-Control module identification”.
- Select “Master”.
- ⇐ Details for both door modules are displayed on the screen <circles>.
- Scroll down so the screen displays the information for both door modules.

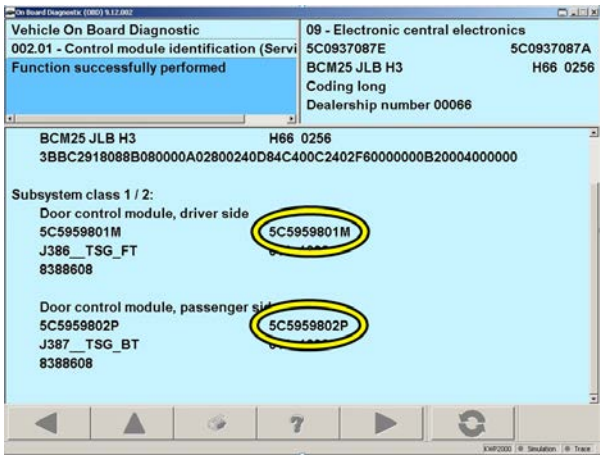

**Updated Part Numbers**

- 6R0 959 801 AP -OR- 5C5 959 801M – Driver Side
- 6R0 959 802 BC -OR- 5C5 959 802P– Passenger Side
- If an updated motor is installed on both sides, repairs complete. **Proceed to Section I.**

The repair information in this document is intended for use only by skilled technicians who have the proper tools, equipment and training to correctly and safely maintain your vehicle. These procedures are not intended to be attempted by “do-it-yourselfers,” and you should not assume this document applies to your vehicle, or that your vehicle has the condition described. To determine whether this information applies, contact an authorized Volkswagen dealer. ©2013 Volkswagen Group of America, Inc. and Volkswagen Canada. All Rights Reserved.

- If one or both of the motors do not match the updated part numbers **Continue to Section C.**

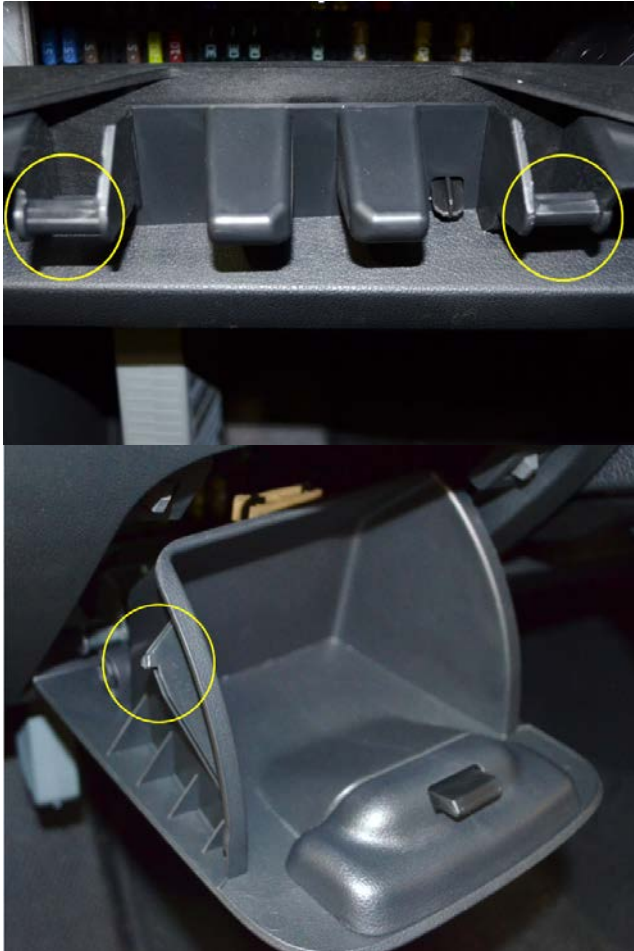

### Section C – Remove driver side glove compartment.

- ⇐ The driver side glove compartment hinges snap into place here <circles>.
- Open the glove compartment
- Pull outward on the storage tray to disconnect the hinges.

**Note:** It may be easier to disconnect one side at a time.

- ⇐ Tilt the storage tray to maneuver the locking tab <circle> past the IP assembly.

**Note:** There is a tab located on each side of the storage tray.

- Remove the storage tray from the vehicle.

**Continue to section D.**



## Section D – Fuse Removal

### General information:

- Before beginning disassembly, FUSES for door control units (window motors) **MUST BE REMOVED!**
- During removal of fuses, the front **DOORS MUST BE OPEN!**
- The Adhesive **MUST** cure for three (3) hours before windows are operated. During this time, windows **MUST NOT MOVE!**
- Fuses may **ONLY** be installed **AFTER** the three (3) hour cure time.



Follow these steps in order to ensure windows are in the proper service position **PRIOR** to removing fuses.

- Close both front doors
- With both front doors closed, fully raise both front windows.
- Open both doors to allow automatic slight drop of windows.
- Leave both doors **OPEN**.

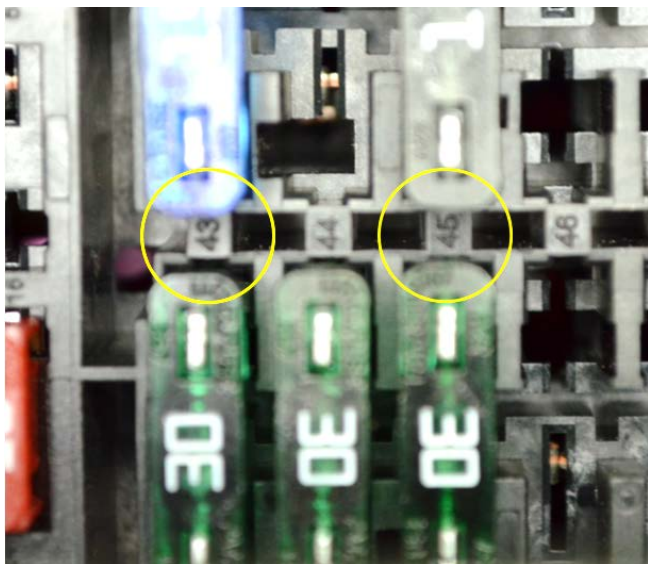

- ⇐ Access the Fuse panel C (driver side, behind glove compartment) and remove the two fuses SC43 and SC45 <arrows> for door control units (window motors).

**Note:** Do not disconnect the battery! Window motors will activate when battery is reconnected to move vehicle during adhesive cure time.

- Press both power window switches to ensure correct fuses were removed. The window motors should not activate. If either of the window motors activates refer to the beginning of **Section D**, remove the correct fuses, then retest operation.

	Motor	Fuse
Passenger side	J387	SC43
Driver side	J386	SC45

**Note:** The fuse panel is also stamped with the fuse numbers as shown <circles>

## Continue to Section E



## Section E – Remove Door Trim



**Tip:** For reference, only one side is shown. This procedure is performed on both the driver side and passenger side.

- Turn off the ignition and all electrical consumers.
- Remove the key.



### CAUTION:

When removing and installing components in visible areas (switches, covers, trim, etc.), cover by taping the areas at which a trim removal tool (3409) will be positioned using commercially available adhesive tape.



### CAUTION:

Take special care when removing and installing trim components as to avoid damage that will lead to customer complaints for noise such as squeaks and rattles. Always replace components that are damaged or no longer serviceable.



- ⇐ Release the window switch trim <1> by gently prying upward on the front edge with trim removal tool (3409) <arrow> and remove it from the door trim panel.



⇐ Disconnect connector <1> and remove the handle trim.

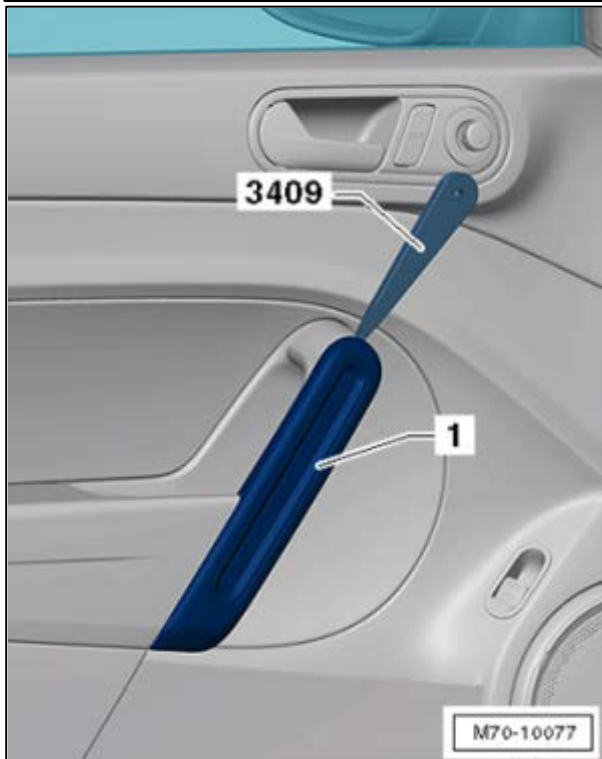

⇐ Remove the upper section of the grip recess <1> from the mount in the door trim panel with the trim removal wedge (3409).

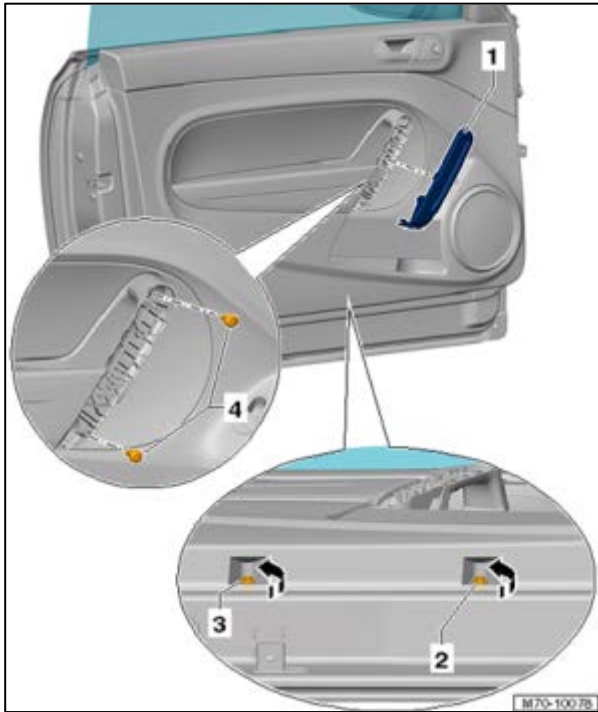

⇐ Remove the screws <4>.

- Turn and release <2 and 3> 90° in direction of the <arrow>.

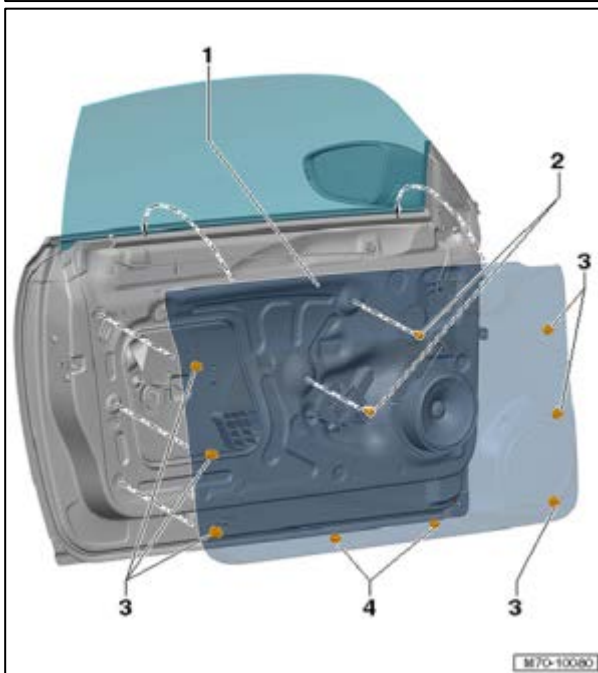

⇐ Turn and release screws <4> 90° to align them with their slot.

⇐ Loosen the clips <3> for the door trim panel out of the mounts <1> with the wedges (T10383).

⇐ Remove the door trim panel <1> vertically from the window shaft seal. If using a trim removal wedge (3409), care must be taken to not damage door panel.

⇐ Disconnect the connectors from the door trim panel <3>.



**Note:** The number of connections between the door panel and the door itself will vary based on vehicle options. Be sure all harness connections are disconnected prior to fully removing the door trim panel.

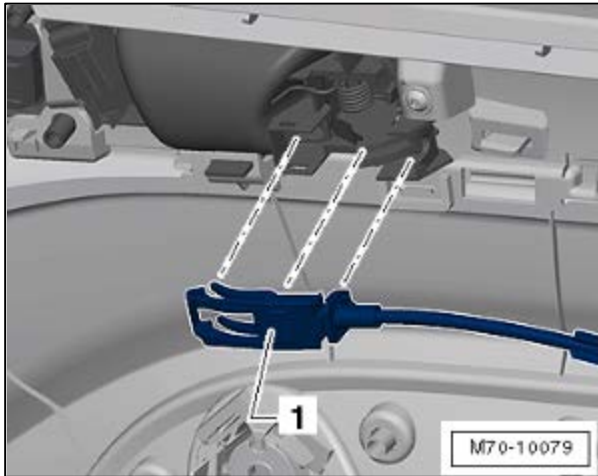

⇐ Disconnect the cable <1> from the interior door mechanism.

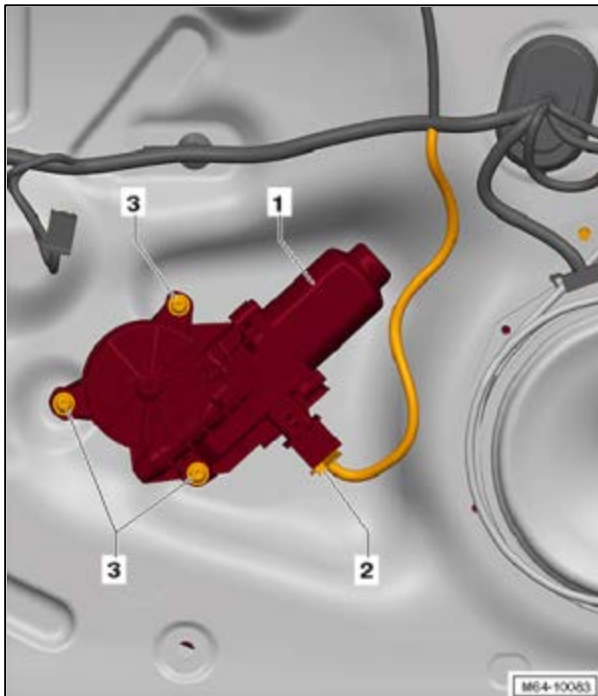

⇐ Secure the door window to prevent it from falling down.

- Disconnect the connector <2>.

⇐ Remove three screws <3>.

**Continue to Section F**

### Section F – Install New Window Motors



⇐ With the aid of trim removal wedge <3409> or equivalent, carefully remove the window regulator motor straight out (not at an angle) from the mounts of the cable reel so that the regulator gear drum does not unseat from its housing.



**CAUTION:**

If regulator gear drum unseats or comes out too far, damage to regulator may occur.

Regulators damaged during this repair will **NOT** be covered under this action.

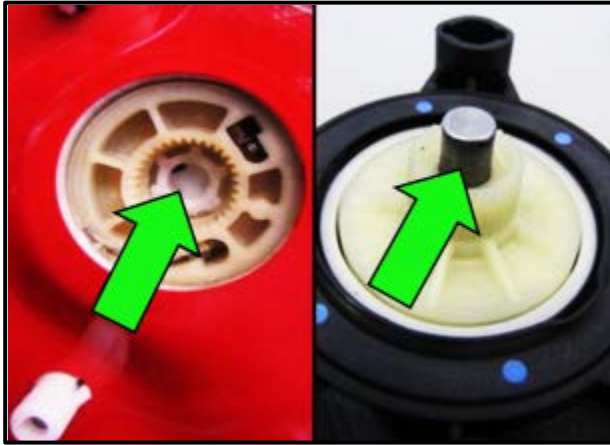

⇐ Using a lint-free cloth and the blade of a screwdriver, wipe excess grease from the centering hole in the regulator <left arrow>.

⇐ Using lint-free cloth, clean any excess grease from window motor shaft <right arrow>.



**Tip:** Do not use cleaning agents when removing grease. It is important that a grease residue remain in the regulator.



**Tip:** Prior to applying the adhesive, it is important to have the parts ready for immediate installation. This adhesive will begin to set up in as quickly as 30 seconds.

⇐ Place a large drop of adhesive part number (D 195 800 A1) as shown <arrow> into the lower corner of the regulator bore.



**CAUTION:** It is important that the adhesive remains only in the regulator bore and does not leak out onto the gear splines. Do not allow adhesive to come in contact with the regulator gear splines.

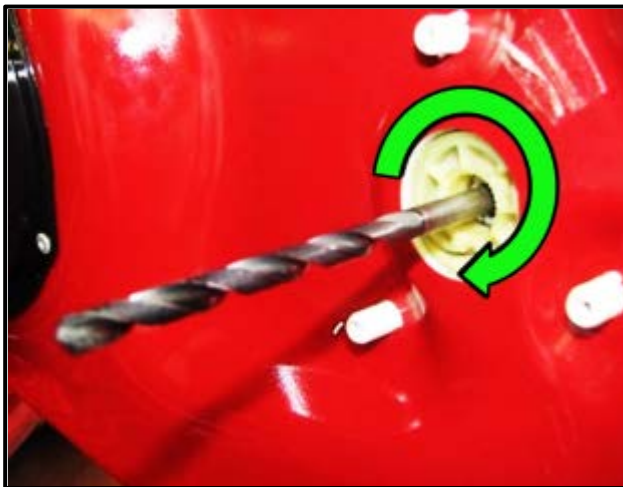

⇐ Using the back side of an 8mm drill bit, lightly insert and rotate drill bit in order to evenly spread the adhesive in the regulator bore inner wall.



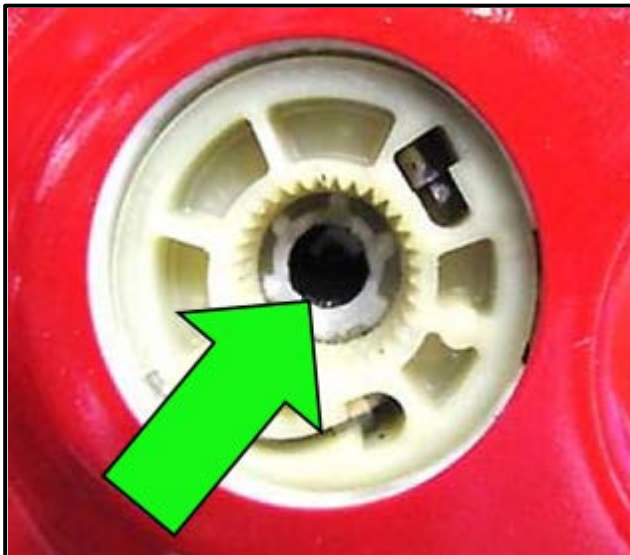

⇐ Place another large drop of adhesive part number (D 195 800 A1) as shown <arrow> into the lower corner of the regulator bore.



**CAUTION:** It is important that the adhesive remains only in the regulator bore and does not leak out onto the gear splines. Do not allow adhesive to come in contact with the regulator gear splines.

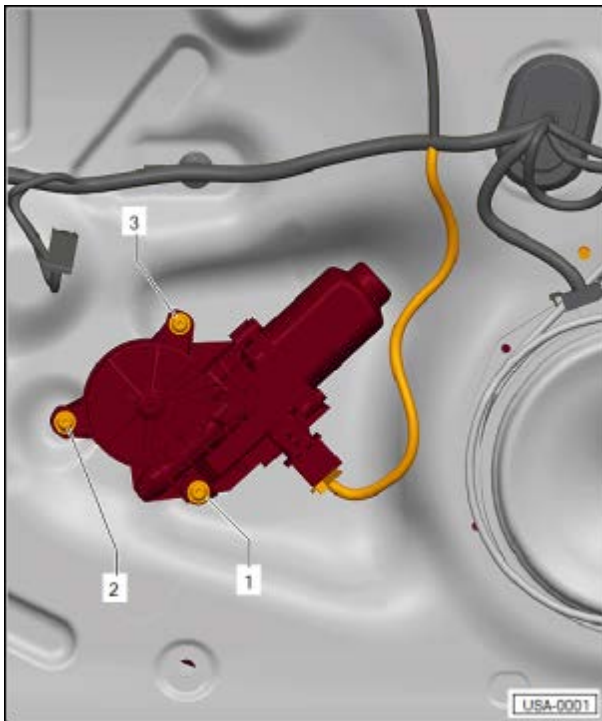

- Carefully install the new window regulator motor (according to the table below) onto the mounts in the cable reel.

Motor Position	Motor Part #
Driver Side	6R0 959 801AP Z01
Passenger Side	6R0 959 801BC Z01



**Note: Critical Torque Sequence!**  
It is very important to follow the specified torque sequence and specified torque value.

- ⇐ Install screws for the motor evenly by hand, and then tighten them in the correct order <1, 2, 3> to 3 Nm.
- ⇐ Connect the electrical connector to the motor.
- Once installation of new motors is complete allow minimum of three (3) hours cure time of adhesive before restoring electrical power to windows. Vehicle may be moved but do not reinstall fuses until cure time is complete.



**CAUTION:** After installation of the window motor(s), the adhesive **MUST** be allowed to cure for at least 3 hours at or near an ambient temperature of 22°C (71°F). During this time, the windows must not move.

**Continue to Section G**



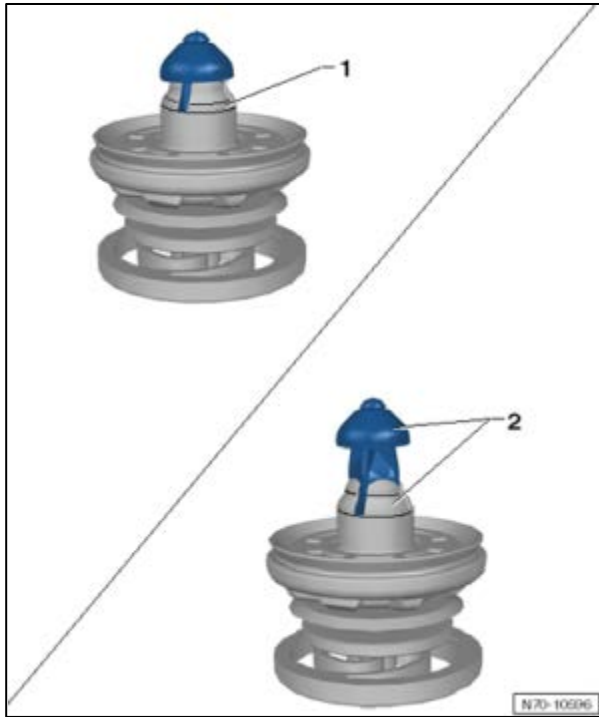

## Section G – Reinstall Door Trim



**Tip:** Use care when reinstalling trim components. Damaged components that may lead to customer dissatisfaction must not be reinstalled. Also remember to clean trim surfaces to help ensure customer satisfaction.



### **CAUTION:**

Before reinstalling the door trim, make sure the locking mechanism of all clip connections are in the <1 position>! It is not possible to install the door trim correctly if the clips are in the <2 position>.

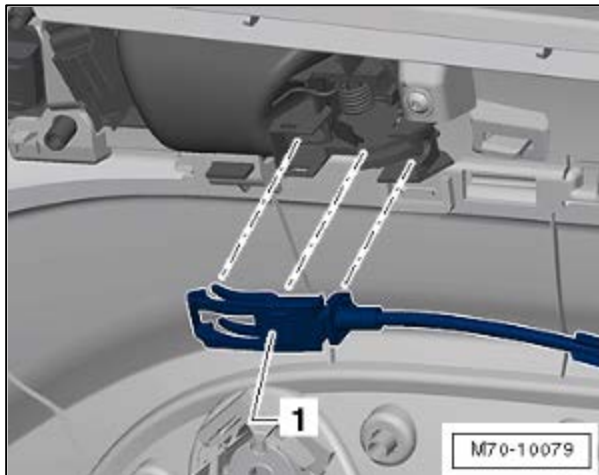

⇐ Reconnect the cable <1> for the interior door mechanism.

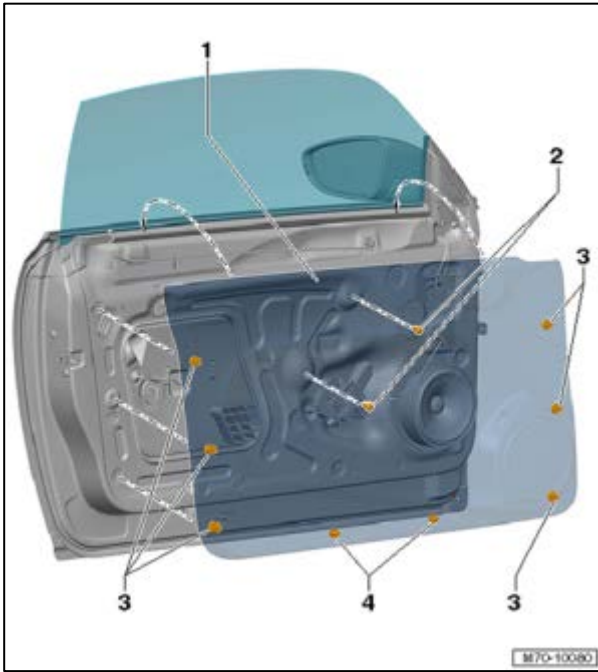

- ⇐ Reconnect all electrical connections and be sure to pull the window switch connectors through the door trip panel for later use. Reconnect all connectors on the backside of the door trim panel <3>.
- ⇐ Reattach the clips <3> for the door trim panel.
- ⇐ Reinstall the door trim panel <1> on the window shaft seal.
- ⇐ Turn and reseal screws <4> 90°.

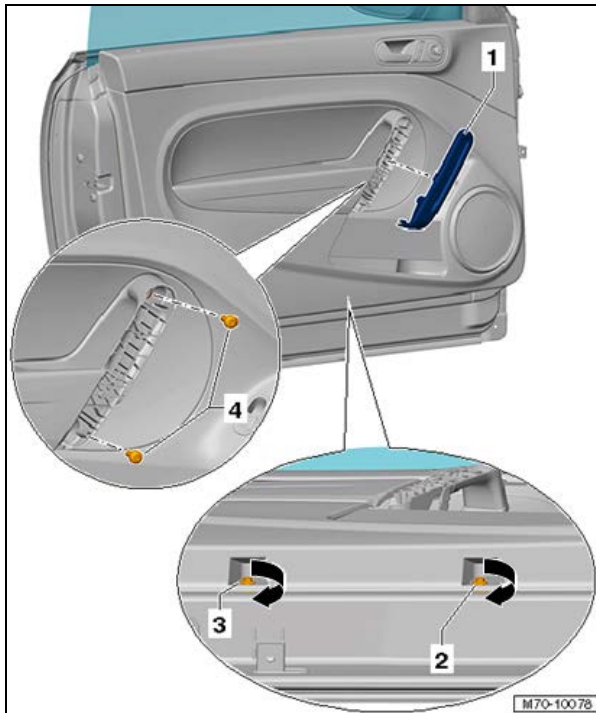

- ⇐ Reinstall the screws <4> (4.5 Nm) with torque wrench (VAG1783).
- ⇐ Turn and secure <2 and 3> 90° in direction of <arrow>.
- ⇐ Reinstall the upper section of the grip recess <1> on the mount in the door trim panel.



- Reconnect the connector <1> and reinstall handle trim.
- ⇐ Once installation of new motor(s) is complete allow minimum of three (3) hours cure time of adhesive before restoring electrical power to windows. Vehicle may be moved but do not reinstall fuses until cure time is complete.

 **CAUTION:** After installation of the window motor(s), the adhesive **MUST** be allowed to cure for at least 3 hours. During this time, the windows must not move.

**Continue to Section H**



**Section H – Reinstall Fuses**

- ⇐ Once minimum 3 hour cure time is complete, reinstall the two fuses SC43 and SC45 <arrows> for door control units (window motors).
- Using the VAS tester, clear all DTC's from the vehicle.

	Motor	Fuse
Passenger side	J387	SC43
Driver side	J386	SC45

- Perform Basic Settings for the window motor as follows:
  - Switch ignition ON.
  - Close door.
  - Fully close window.
  - Pull up on window switch for at least 2 seconds, release switch and then pull switch up momentarily.
  - Automatic up/down function is now available.

### Continue to Section I

### Section I – Campaign Completion Label and Parts Return/Disposal

- Open hood.

#### Install Campaign Completion Label

- ⇐ Fill out and affix Campaign Completion label, part number CAMP 010 000, next to the vehicle emission control information label.



Tip:  
Ensure Campaign Completion label does not cover any existing label(s).

- Close hood.

#### Parts Return/Disposal

Properly destroy and dispose of removed parts in accordance with all state/local requirements once the parts are listed on the Parts Destruction and Core Disposition report, unless otherwise indicated and/or requested for return.

### ALL WORK IS COMPLETE

**Campaign Completion**

SAGA CODE:  
DLR #:  
REPAIR DATE:

CAMP 010 000