



SERVICE CAMPAIGN BULLETIN

Reference:

NTB13-025

Date:

March 21, 2013

VOLUNTARY SERVICE CAMPAIGN 2011 QUEST TOW HITCH INSPECTION

CAMPAIGN I.D.: PC196

APPLIED VEHICLE: 2011 Quest (E52) equipped with a genuine Nissan accessory tow hitch

Check REPAIR OVERVIEW on page 2 to confirm campaign eligibility.

INTRODUCTION

Nissan is conducting a Voluntary Service Campaign on certain Model Year 2011 Nissan Quest vehicles that may be equipped with a genuine Nissan accessory tow hitch. Certain of these accessory tow hitches were manufactured without drain holes, which may result in corrosion. The tow hitch will be inspected for drain holes. If no drain holes are found, the tow hitch will be replaced. Inspection and repairs (as they apply) will be performed at no charge for parts or labor.

NUMBER OF VEHICLES POTENTIALLY AFFECTED

Campaign notices are being sent to approximately 10,978 owners of Model Year 2011 Quest vehicles who may have purchased and then had installed (or whose vehicles may have come equipped with) one of the subject tow hitches. However, the total number of Nissan vehicles affected (i.e., equipped with genuine Nissan accessory tow hitches that require replacement) is approximately 341.

IDENTIFICATION NUMBER

Nissan has assigned identification number **PC196** to this campaign. The correct number must appear on all communications and documentation of any nature dealing with this campaign.

DEALER RESPONSIBILITY

Dealers are to correct each vehicle falling within the range of this campaign that enters the service department. This includes vehicles purchased from private parties or presented by transient (tourist) owners and vehicles in a dealer's inventory.

REPAIR OVERVIEW

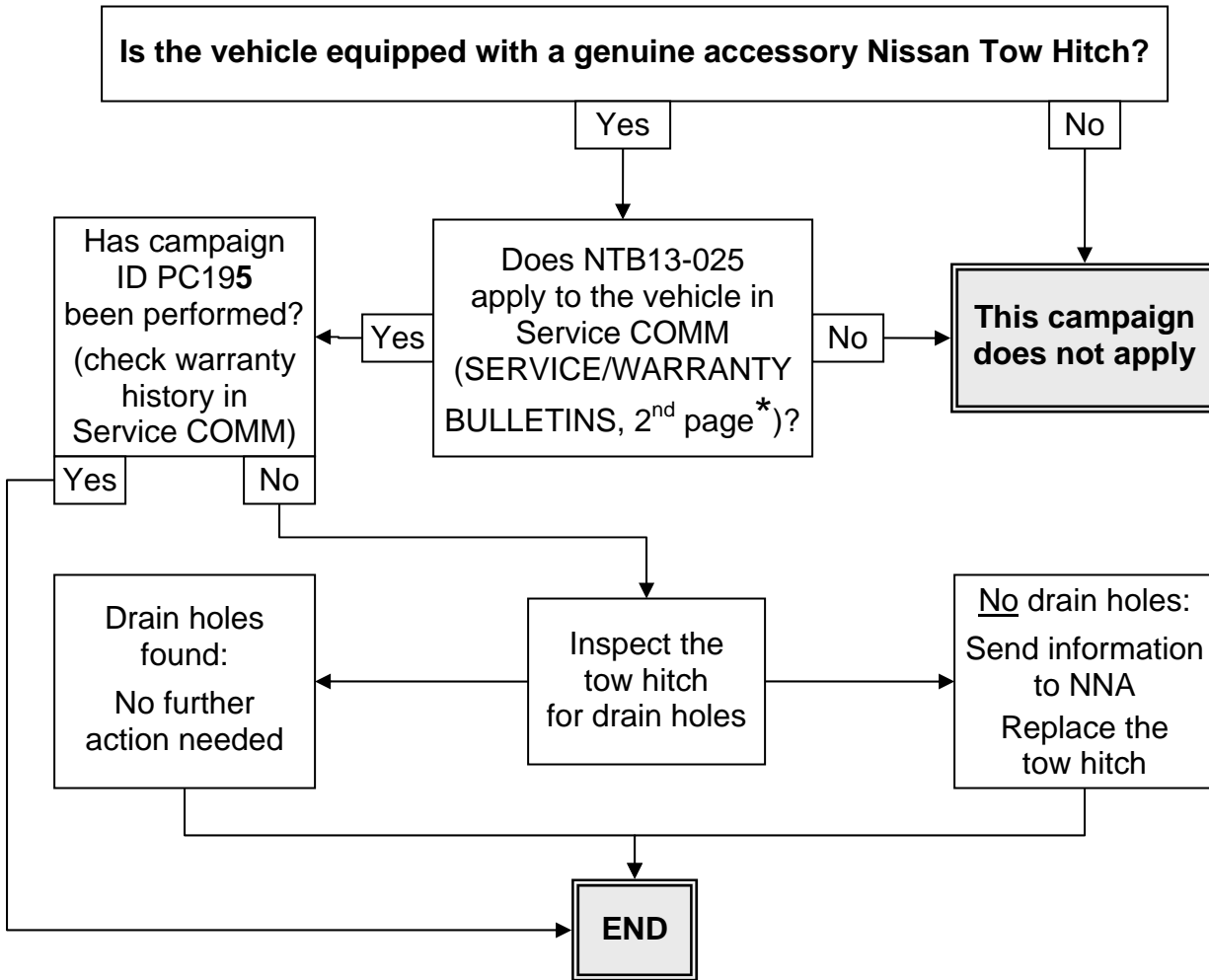

* Example Screen

```

VATH/VAPC990          SERVICE/WARRANTY BULLETINS          XXXXX
AFFILIATE:  N
REFERENCE:  pc196          POSTED-DATE :  XXXXXXXX
-----
VIN MASK          VIN SERIAL          VIN MASK          VIN SERIAL
FROM              TO                  FROM              TO
-----
XXXXXXXX          000001  000001          _____
_____
_____
_____
DESCRIPTION:  NTB13-025 2011 QUEST TOW HITCH INSPECTION
APPLID
REMARKS:      MOST QUEST VEHICLES ARE NOT EQUIPPED WITH A TOW HITCH.
              THIS INSPECTION SHOULD ONLY BE PERFORMED IF THE VEHICLE
              IS EQUIPPED WITH A GENUINE NISSAN TOW HITCH.
USERID:       V0581W          LAST UPDATED ON :  X01X-X2-XX
GOTO:  _____  MESSAGE:  156-REFERECE DETAILS UPDATED
F1=HELP  F2=          F3=EXIT  F4=MENU  F5=REFRESH  F6=
F7=          F8=          F9=CLEAR  F10=          F11=          F12=DELETE
  
```

SERVICE PROCEDURE

Replace Genuine Nissan Accessory Tow Hitch

NOTE: For more details on replacement, refer to the 2011 Quest Trailer Tow Hitch Installation Instructions in ASiST located under the **Acc. Install Instructions** tab.

If campaign ID # PC196 applies:

Replace the tow hitch only if:

- The vehicle has a genuine Nissan accessory tow hitch

AND

- The tow hitch does not have drain holes where shown on the next page.
 - If both apply, a part order approval is needed.
 - For part order approval, send the VIN, your dealer code and “facing” PDC, and clear pictures of the genuine Nissan accessory tow hitch without holes to nafgasupport@nissan-usa.com. You will get a return confirmation of approval to order the replacement tow hitch.

Do not replace the tow hitch if:

- The vehicle is not equipped with a tow hitch

OR

- There is a genuine Nissan accessory tow hitch with drain holes

OR

- The vehicle is equipped with a tow hitch that is not a genuine Nissan accessory tow hitch.

Go to page 4 for inspection location, and page 5 for replacement procedure.

WARNING: Be careful if inspecting from the passenger side. The exhaust tail pipe may be hot.



Passenger side



Driver side

For part order approval procedure, go to page 3.

1. Remove the two (2) rear bumper fascia fasteners on each side.

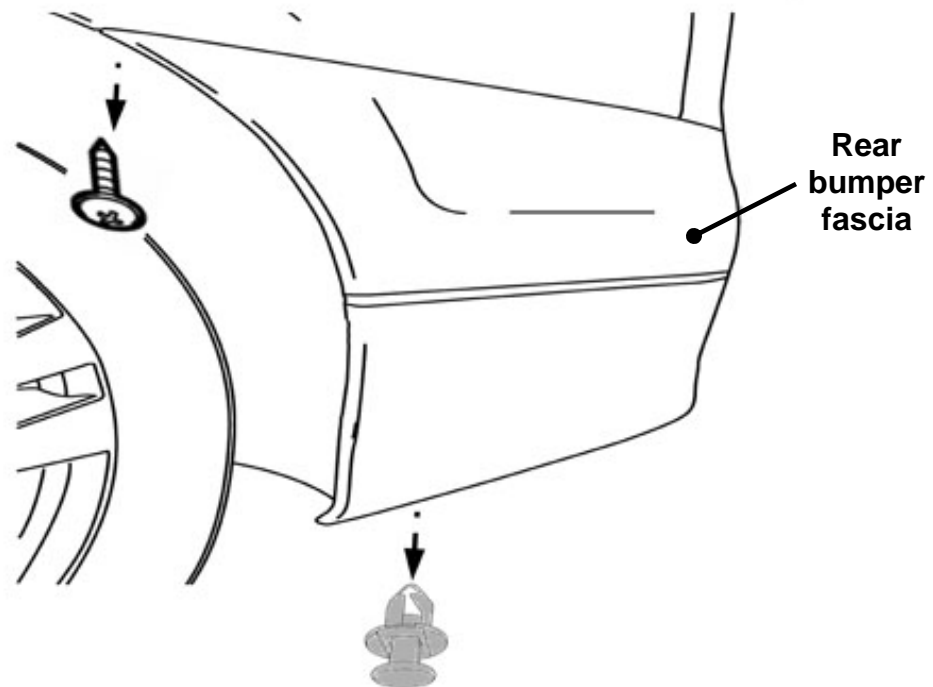

Figure 1

2. Remove the two (2) clips shown in Figure 2.

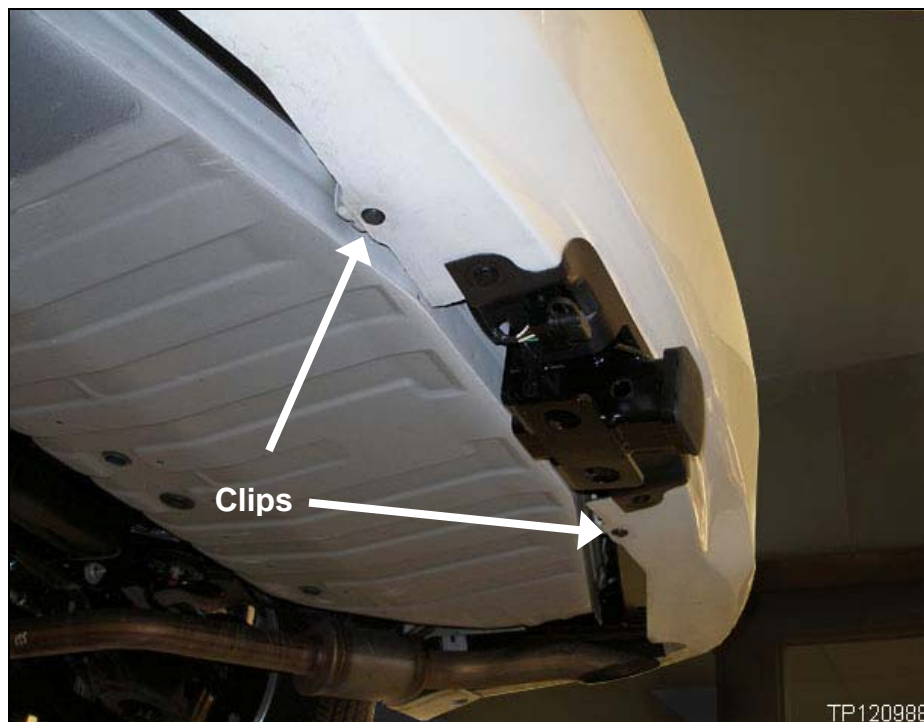

Figure 2

4. Remove the 4-pin connector.

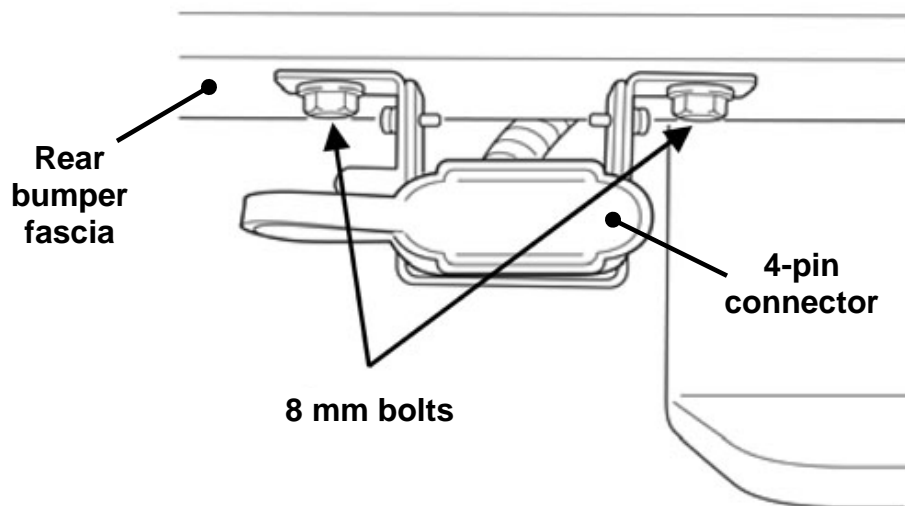

Figure 3

5. Carefully unfasten both sides of the rear bumper fascia by pulling outward.



Figure 4

5. Carefully remove the rear bumper fascia.

NOTE: This is a two-person job.

CAUTION: Store the rear bumper fascia in a place where it will stay clean and undamaged.

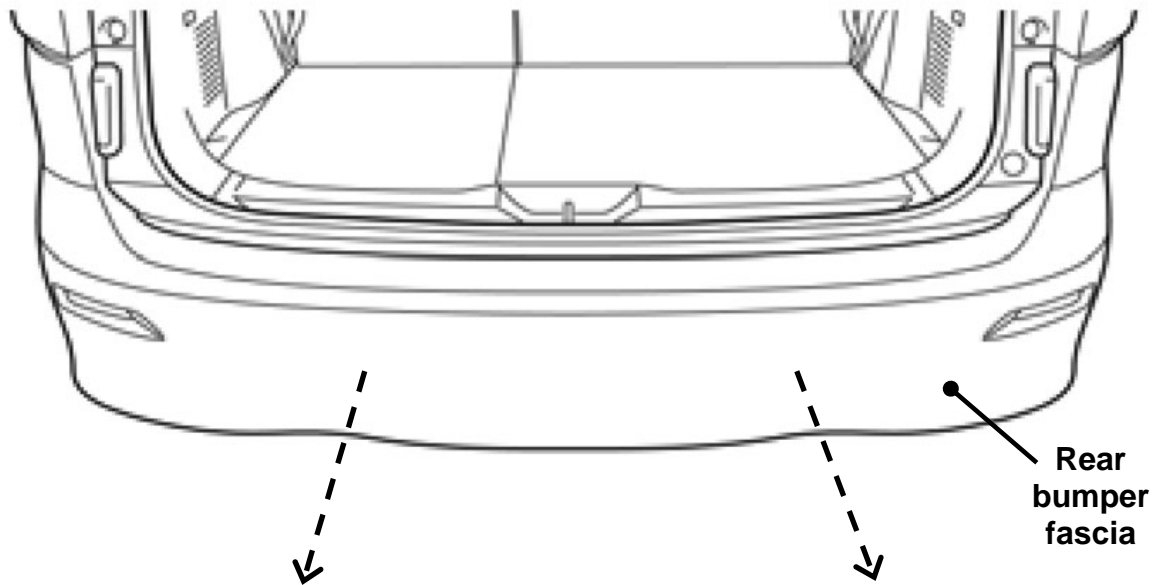

Figure 5

3. Unfasten all nine (9) harness clips from the hitch.

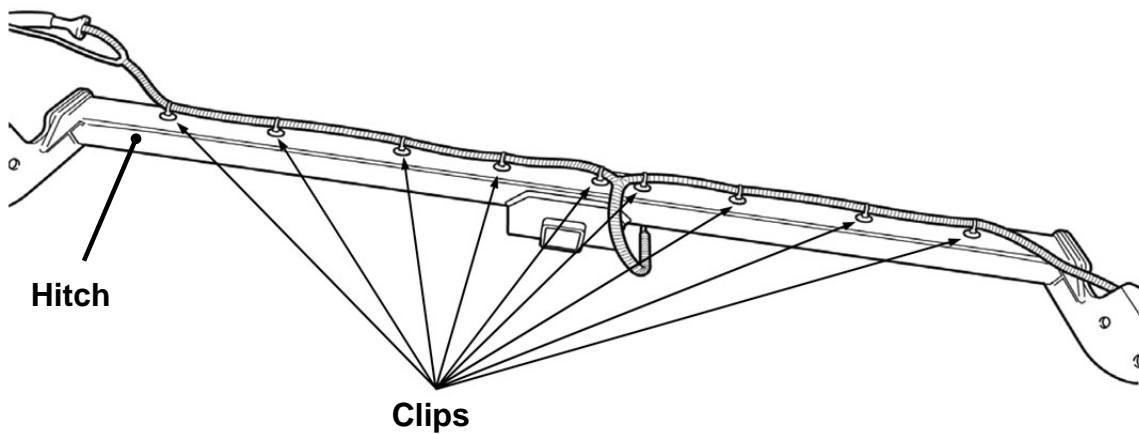

Figure 6

5. Unhook the rear exhaust hanger (for additional clearance).



Figure 7

6. Unbolt the three (3) bolts on each side, and then remove the tow hitch.

NOTE: This is a two-person job.

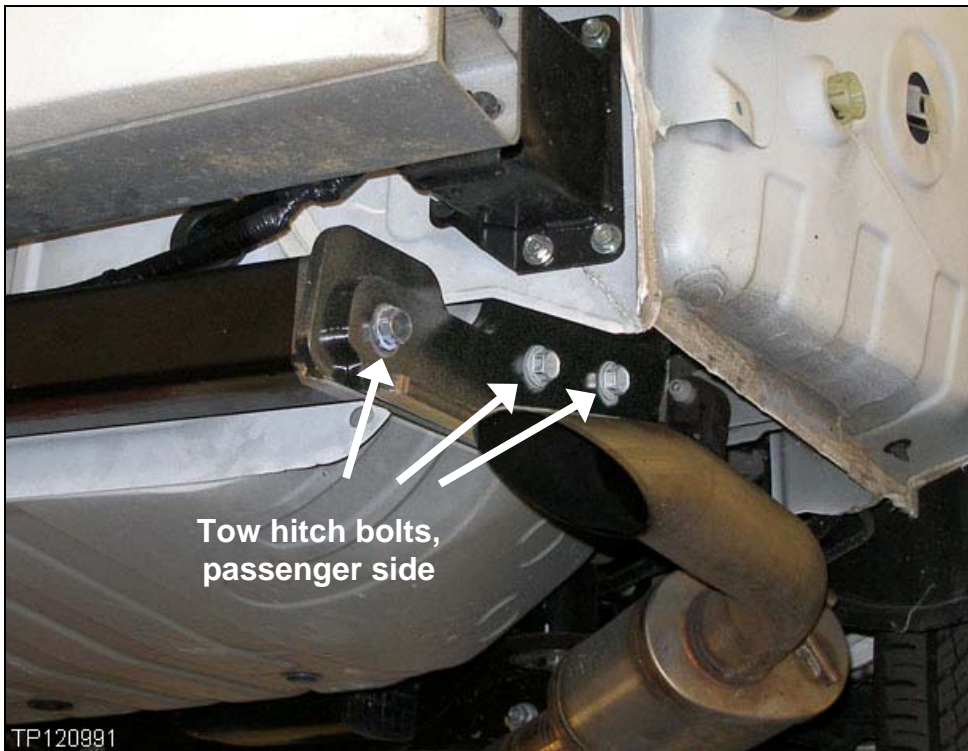

Figure 8

7. Install the new tow hitch in reverse order of removal.

Tow hitch bolts torque: 110-150 N•m (11.2-15.3 kg-m, **73-96 ft lbs**)

4-pin connector bolts torque: 3.9 N•m (0.39 kg-m, **35 in lbs**)

PARTS INFORMATION

DESCRIPTION	PART NUMBER	QUANTITY
Quest Tow Hitch *	999T5-NW010	1

* See page 3 for part order details.

CLAIMS INFORMATION

Submit a Campaign (CM) line claim using the applicable claims coding below:

CAMPAIGN ID #	DESCRIPTION	OP CODE	FRT
PC196	Inspect Tow Hitch Only	PC1960	0.2 hrs

OR

CAMPAIGN ID #	DESCRIPTION	OP CODE	FRT
PC196	Inspect and Replace Tow Hitch	PC1961	1.0 hrs

OWNER'S LETTER (typical example of owner's letter)

Dear Nissan Quest Owner:

Nissan is committed to providing the highest levels of product quality and customer satisfaction. We believe that our current and future success depends on your continued satisfaction with Nissan. With that in mind, we want to bring to your attention important information regarding your vehicle.

REASON FOR SERVICE CAMPAIGN

Some potentially affected 2011 Quest vehicles with an installed accessory Tow Hitch may have been equipped with Tow Hitch Cross Tubes that do not contain drain holes. As a result, water may be prevented from draining properly and potentially cause corrosion. This is not a safety issue, and the vehicle still meets and/or exceeds all applicable safety standards.

WHAT NISSAN WILL DO

Although your vehicle was not equipped from the factory with a Tow Hitch Assembly, it is possible that an affected accessory Tow Hitch may have been installed on your vehicle at a later date. If your vehicle does not have a Tow Hitch installed, there is no action necessary on your part and you may disregard this notice. If a Tow Hitch has been installed on your vehicle, to assure your continued satisfaction and confidence in your vehicle, we ask that you bring your vehicle to your nearest authorized Nissan dealer who will confirm whether your Tow Hitch lacks drain holes. If it lacks drain holes, your Nissan dealer will replace the Tow Hitch Assembly at **no charge to you for parts or labor**. The service should take about an hour to complete, but your Nissan dealer may require your vehicle for a longer period of time based upon their work schedule.

WHAT YOU SHOULD DO

Check the illustrations on the reverse side of this letter to help you in determining if your vehicle is equipped with a Tow Hitch Assembly. If your vehicle does not have a Tow Hitch, no further action is required. If you determine your vehicle has a Tow Hitch, please contact your Nissan dealer at your earliest convenience in order to arrange an appointment for an inspection of the Tow Hitch and, if necessary, a replacement. Alternatively, if you prefer, you may inspect the Tow Hitch yourself to determine if drain holes are present as shown in the attached illustration. If drain holes are present, no further action is required. If drain holes are not present, or if you are unsure whether drain holes are present, please contact your Nissan dealer to schedule an appointment. **To ensure the least inconvenience for you, it is important that you have an appointment before bringing your vehicle to the Nissan dealer for service.** Please bring this notice with you when you keep your service appointment. Instructions have been sent to your Nissan dealer.

If the dealer fails, or is unable to complete the service free of charge, you may contact the National Consumer Affairs Department, Nissan North America, Inc., P.O. Box 685003, Franklin, TN 37068-5003. The toll free number is 1-800-NISSAN1 (1-800-647-7261).

Thank you for providing us an opportunity to ensure on-going satisfaction with your Nissan vehicle.