



Applies To: 2009-13 TL – ALL
2009-13 TSX – ALL

March 8, 2013

Front Suspension Clunk in Hot Weather

(Supersedes 12-041, dated February 28, 2013, to revise the information marked by the black bars)

REVISION SUMMARY

Under POSSIBLE CAUSE, CORRECTIVE ACTION, PARTS INFORMATION, WARRANTY CLAIM INFORMATION, and REPAIR PROCEDURE, information was changed. Under Applies To, 2013 models were added.

SYMPTOM

A clunk is heard in the front suspension while driving over irregular surfaces and in hot weather. The noise goes away temporarily when the vehicle is lifted in the air (the suspension is allowed to hang) and then returned to the ground.

POSSIBLE CAUSE

Hot weather causes the grease to pool on the bottom of the ball joint, causing a knocking noise.

CORRECTIVE ACTION

Replace both of the front lower ball joints with the service parts made to address this specific symptom. If the lower ball joints were previously replaced, then replace both front knuckle assemblies with those listed in this bulletin.

PARTS INFORMATION

Part Information - TL	Part Number	Qty.
Front Lower Ball Joint	51220-TA0-306	2
B/J Castle Nut	90363-TK4-A01	2
B/J Cotter Pin	94201-30220	2
Spindle Nut	90305-S3V-A11	2
Tie Rod Cotter Pin	94201-30220	2
Upper Arm B/J Cotter Pin (if knuckle replaced)	94201-20220	2
Wheel Bearing (if knuckle replaced)	44300-TA0-A61	2
Snap Ring (if knuckle replaced)	90681-SJK-000	2
Knuckle Assy, Left (only if prior balljoint replaced)	51215-TK4-Y00	1
Knuckle Assy, Right (only if prior balljoint replaced)	51210-TK4-Y00	1

Part Information - TSX	Part Number	Qty.
Front Lower Ball Joint	51220-TA0-306	2
B/J Cotter Pin	94201-30220	2
Spindle Nut	90305-S3V-A11	2
Tie Rod Cotter Pin	94201-30220	2
Upper Arm B/J Cotter Pin (if knuckle replaced)	94201-20220	2
Wheel Bearing (if knuckle replaced)	44300-TA0-A61	2
Snap Ring (if knuckle replaced)	90681-SJK-000	2
Knuckle Assy, Left (only if prior balljoint replaced)	51215-TA0-Y10	1
Knuckle Assy, Right (only if prior balljoint replaced)	51210-TA0-Y10	1

TOOL INFORMATION

Tool Description	Part Number
Adapter G	07XAF-001050A 07XAF-00105B
Ball Joint Remover, 28 mm	07MAC-SL0A202
Ball Joint Thread Protector, 10 mm	07AAF-SECA120
Ball Joint Thread Protector, 12 mm	07AFF-SDAA100
Ball Joint Thread Protector, 14 mm	07AAE-SJAA100
Ball Joint Tool Kit	07AAF-TL2A150 (contains the following parts) 07AAF-TL2A100 07AAF-TL2A300A 07AAF-TL2A300B 07AAF-TL2A400
Bearing Driver Attachment	07746-0010600
C-Frame	OTC7248 (or commercially available)
Driver Handle	07749-0010000
Oil Seal Driver Attachment 96 mm	07ZAD-PNAA100
Hub Assembly/Disassembly Pin, 42 mm	07GAF-SD4A100
Support Base	07965-SD90100

WARRANTY CLAIM INFORMATION

The normal warranty applies.

***Only one of the repairs below will apply.**

OP#	Description	FRT
4151A9	Replace both front knuckle assemblies with ball joints that address this symptom.	2.3
A	Alignment - add	0.4

OP#	Description	FRT
4161C0	Replace both front ball joints.	1.5
A	Alignment - add	0.4

Failed Part: P/N 51220-TA0-A02

Defect Code: 07409

Symptom Code: 04201

Skill Level: Repair Technician

DIAGNOSIS

Raise the vehicle on a lift high enough to let the suspension hang. Lower the vehicle, then test-drive it and listen for a clunking noise.

- If the noise is gone, go to REPAIR PROCEDURE.
- If the noise is still there, this bulletin does not apply. Continue with normal troubleshooting.

REPAIR PROCEDURE

1. Raise and support the vehicle.

NOTE: Do this repair to both sides of the front suspension.

2. Remove the wheel nuts and the front wheel.

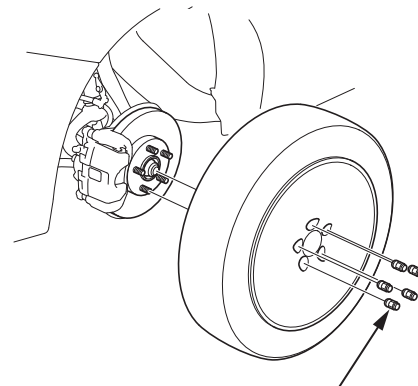

WHEEL NUTS
TSX - 108 N·m (80 lb-ft)
TL - 127 N·m (94 lb-ft)

3. Clean the top surface of both lower ball joints in the front knuckles and inspect for a paint mark, indicating prior replacement.
 - If there is a paint mark, replace both front knuckle assemblies with ones listed in this bulletin.

NOTE: Ball joints can only be replaced one time on a knuckle and then it requires replacement.

- If there is no paint mark, replace both lower ball joints.

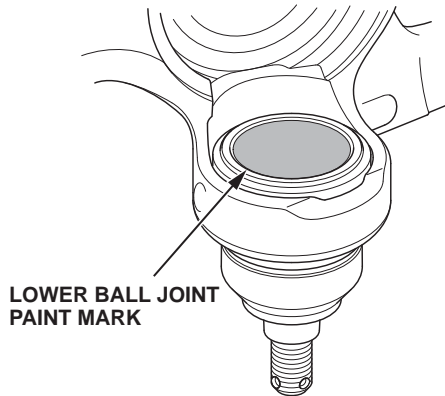

4. Remove the wheel speed sensor and its harness brackets at the knuckle assembly and at the damper assembly. Do not disconnect the wheel speed sensor connector.
 - If using the existing knuckle assemblies, go to step 7.
 - If replacing knuckle assemblies, go to step 5.

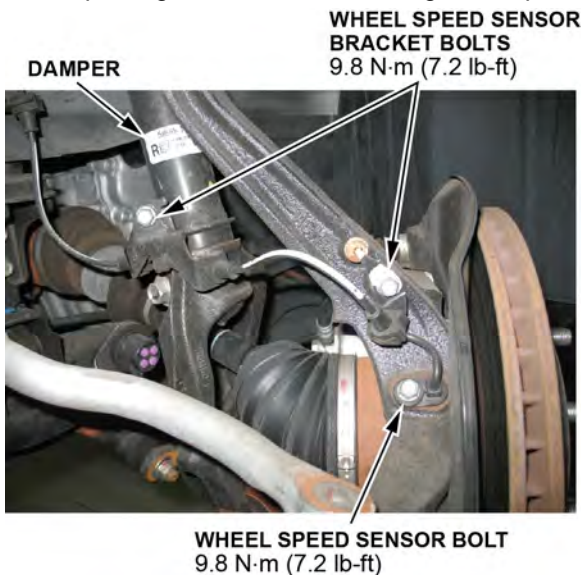

5. Remove the brake hose bracket mounting bolt from the knuckle.

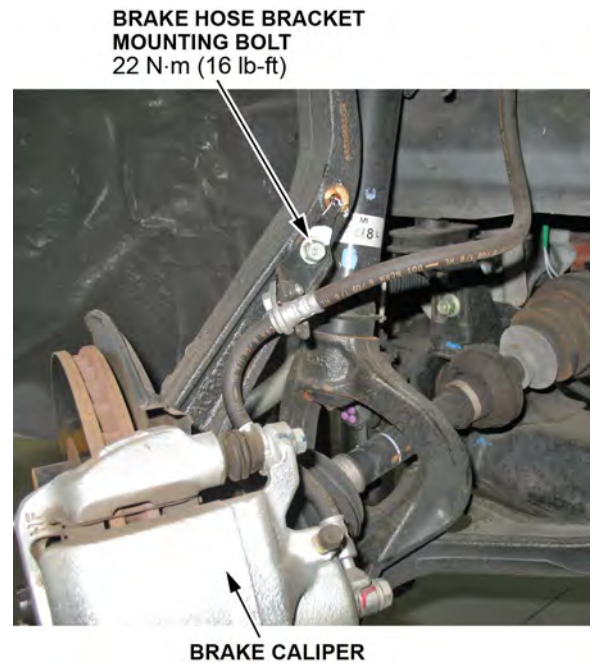

6. Remove the brake caliper bracket mounting bolts, then remove the caliper assembly from the knuckle. To prevent damage to the caliper assembly or the brake hose, use a short piece of wire to hang the caliper assembly from the undercarriage. Do not twist the brake hose excessively.

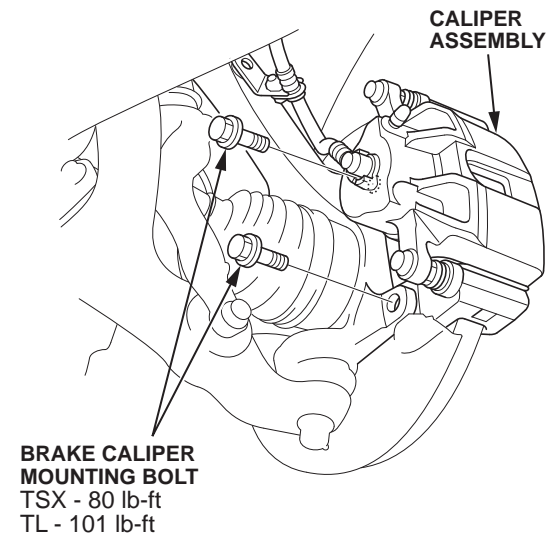

7. Pry up the stake on the spindle nut, then remove the nut.
 - If replacing the knuckle assemblies, go to step 8.
 - If using existing knuckle assemblies, go to step 9.

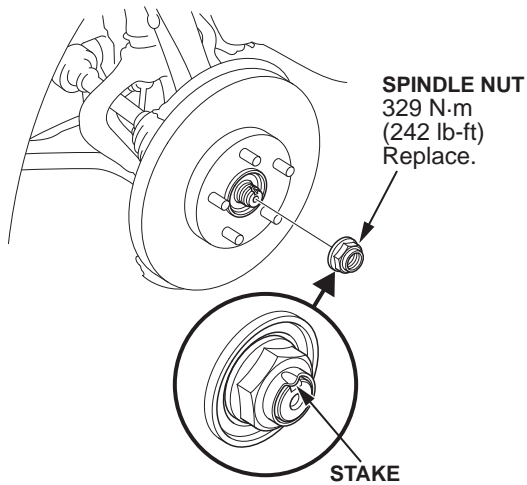

8. Remove the front brake disc.
 - Remove the brake disc flathead screws.
 - Remove the brake disc from the front hub.
 - Check the front hub for damage and cracks.

NOTE: If the brake disc is stuck to the front hub, thread two (8 x 1.25 mm) bolts into the brake disc to push it away from the front hub. Turn each bolt 90° at a time to prevent the brake disc from binding.

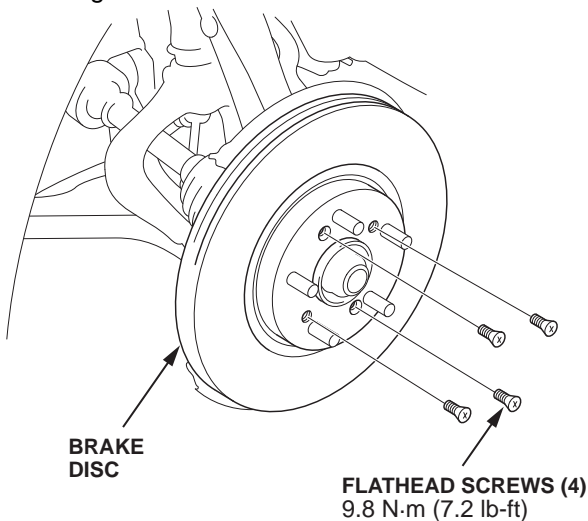

9. Remove the cotter pin from the tie-rod end ball joint, then remove the nut.

NOTE: During installation, install a new cotter pin after tightening the nut, and bend its end as shown.

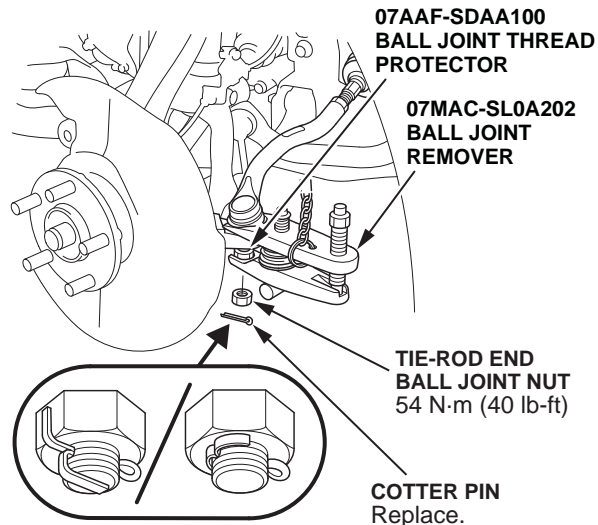

10. Disconnect the tie-rod end ball joint from the knuckle using the ball joint thread protector and the ball joint remover.

11. Remove the cotter pin from the knuckle ball joint, then remove the castle nut.

NOTE:

- TL model – during reassembly, use a new castle nut and insert a new cotter pin into the ball joint pin hole from the front to the rear of the vehicle, and bend its end as shown. Check the ball joint pin hole direction before connecting the ball joint.
- TSX model – during reassembly re-use the castle nut and insert a new cotter pin to the ball joint pin hole from the front to the rear of the vehicle, and bend its end as shown. Check the ball joint pin hole direction before connecting the ball joint.

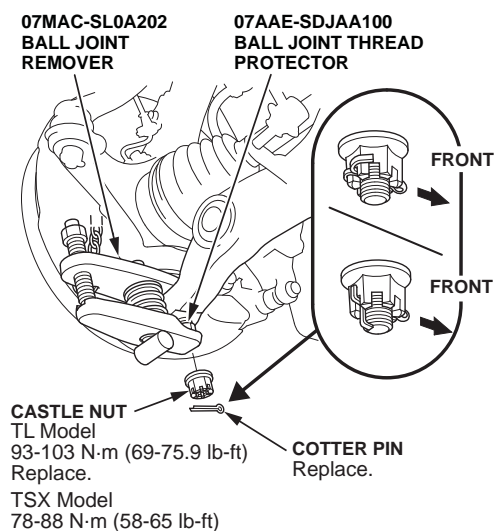

12. Disconnect the knuckle ball joint from the lower arm using the ball joint thread protector and ball joint remover.

NOTE: Do not force or hammer on the lower arm or pry between the lower arm and the knuckle.

- If replacing the knuckle assemblies, go to step 13.
- If using existing knuckle assemblies, go to step 15.

13. Remove the cotter pin from the upper arm ball joint, then remove the castle nut.

NOTE: During reassembly, install a new cotter pin into the ball joint pin hole from the front to the rear of the vehicle, and bend its end as shown. Check the ball joint pin hole direction before connecting the ball joint.

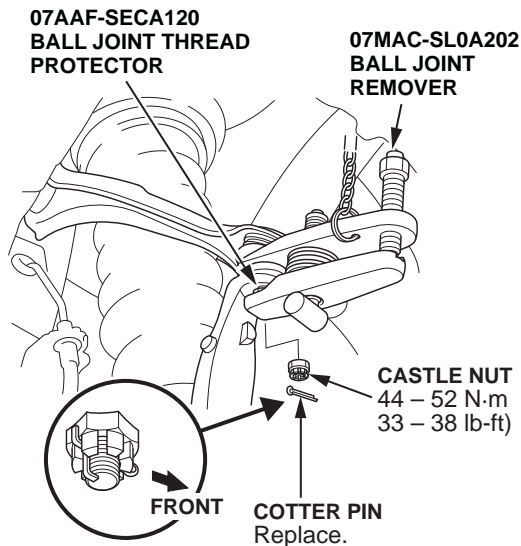

14. Disconnect the upper arm ball joint from the knuckle using the ball joint thread protector and the ball joint remover.

15. Pull the knuckle outward, and separate the outboard joint from the front hub using a soft face hammer outward.

- If replacing the knuckle assembly, remove it.
- If using existing knuckle assembly, move it aside.

NOTE: Do not pull the driveshaft end outward. The driveshaft inboard joint may come apart. During installation, apply grease to the mating surfaces of the wheel bearing and the driveshaft outboard joint.

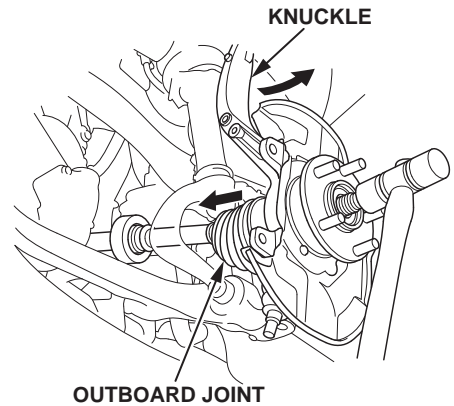

16. Remove the front knuckle ring from the knuckle. Inspect it for deformation and damage, and replace it if needed.

- If replacing the knuckle assemblies, put the old knuckle assembly in a vice to remove the front knuckle ring. Remove the knuckle from the vice once the ring is removed, then go to step 17.
- If using existing knuckle assemblies, go to step 27.

NOTE: When installing the front knuckle ring, position the knuckle ring notch portion toward the cutout near the ball joint in the knuckle, and align the center of the knuckle ring ledge portion with the center of the wheel speed sensor hole on the knuckle.

Removal:

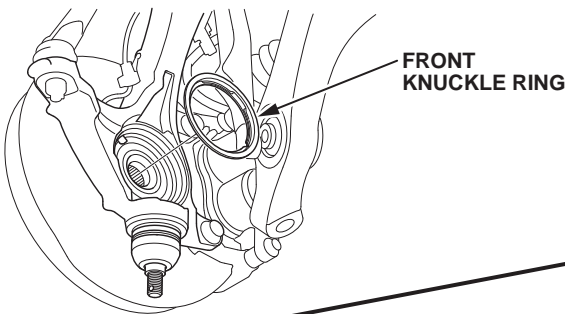

Installation:

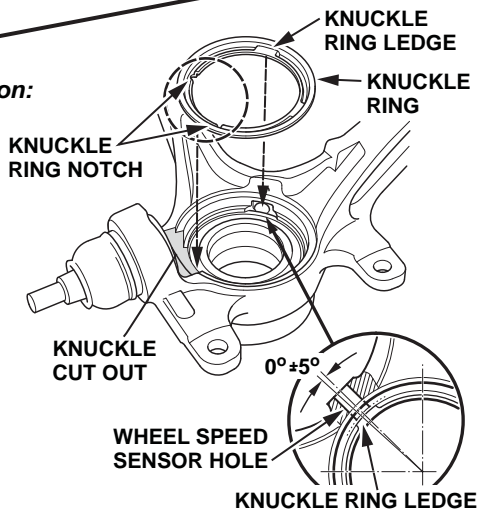

17. Separate the hub from the old knuckle using the hub dis/assembly pin and a hydraulic press. Hold the knuckle with the hydraulic press attachment or equivalent tool. Be careful not to damage or deform the splash guard. Hold onto the hub to keep it from falling when pressed clear.

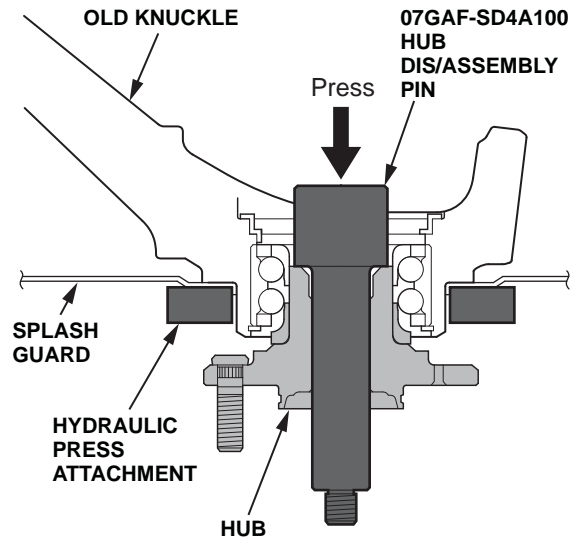

18. Press out the wheel bearing inner race of the hub using the hub dis/assembly pin, a commercially available bearing separator, and a hydraulic press.

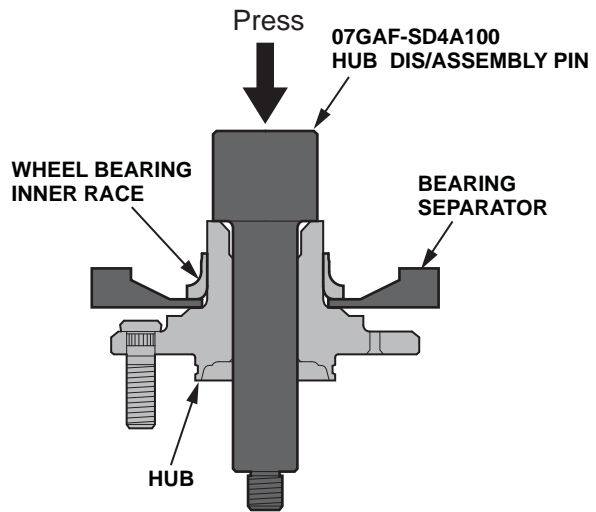

19. Remove the snap ring and the splash guard from the knuckle.

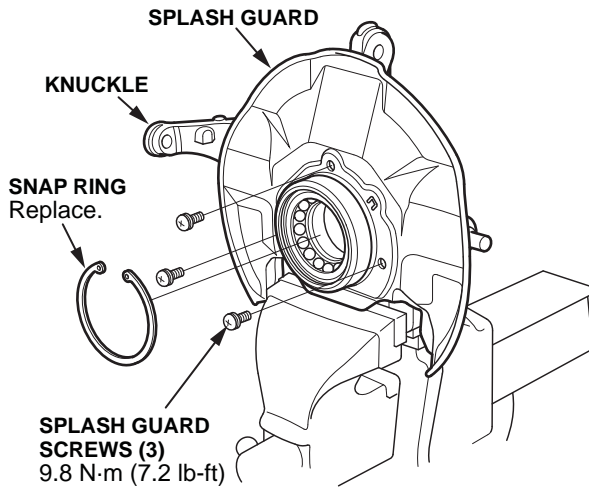

20. Press the wheel bearing out of the knuckle using the driver handle, the attachment, and a press.

NOTE: This old wheel bearing will be used to assist in the installation of the new wheel bearing into the new knuckle assembly.

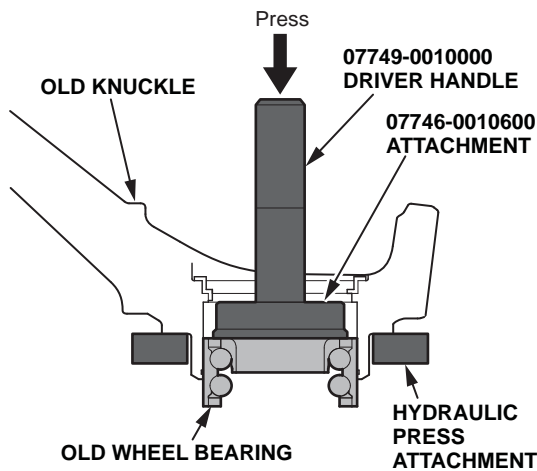

21. Press a new wheel bearing into the new knuckle using the old bearing, a steel plate, the attachment, the support base, and a press.

NOTE:

- Install the new wheel bearing with the wheel speed sensor magnetic encoder (brown color), toward the inside of the knuckle.
- Remove any oil, grease, dust, metal debris, and other foreign material from the magnetic encoder surface.
- Keep any magnetic tools away from the magnetic encoder surface.
- Be careful not to damage the magnetic encoder surface when you insert the new wheel bearing.

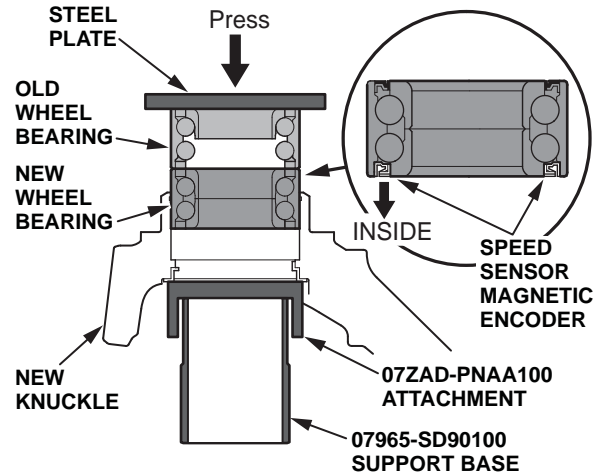

22. Set the new knuckle assembly in a vice to hold it securely and install the front knuckle ring:

NOTE: Inspect the front knuckle ring for damage or deformation prior to installation, and replace it if necessary.

Position the knuckle ring notch portion toward the cut out near the ball joint in the knuckle, and align the center of the knuckle ring ledge portion with the center of the wheel speed sensor hole on the knuckle.

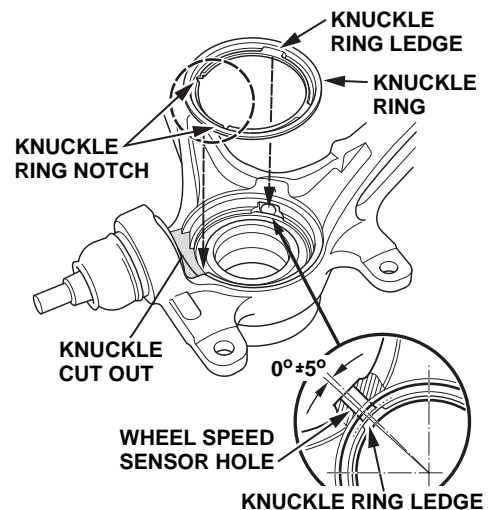

23. Install a new snap ring securely in the knuckle.
24. Install the splash guard, and tighten the screws to the specified torque, then remove the knuckle assembly from the vise.

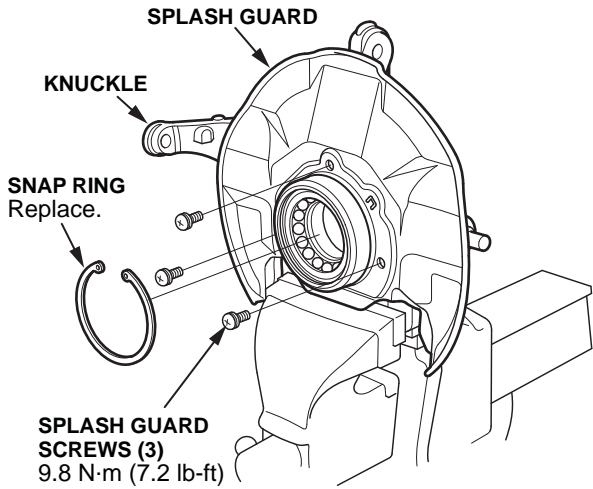

25. Install the hub onto the new knuckle assembly using the driver handle, the attachment, the support base, and a hydraulic press. Be careful not to damage the splash guard.

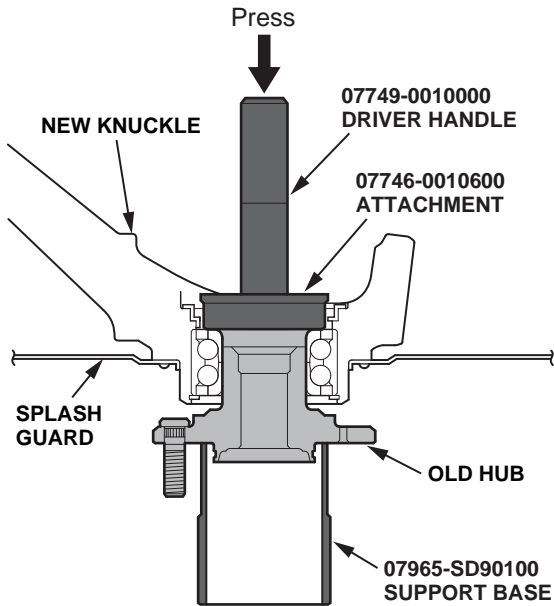

26. Install the new knuckle assembly, then go to step 35.

27. Remove the boot clip, then remove the boot off the ball joint, and wipe the grease off the exposed portion.

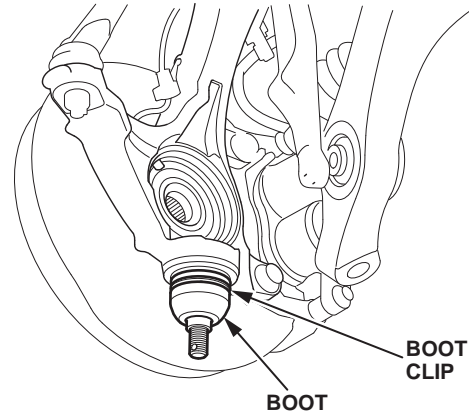

28. Clean and wipe off the hub center, then install the attachments (07AAF-TL2A300-A and B) of the ball joint tool kit through the hub center. Position the projection of the attachment (07AAF-TL2A300-B) toward the lower side of the knuckle. Tighten it into place by hand.

NOTE: Make sure that the flat part of the attachment is parallel to the top of the knuckle ball joint.

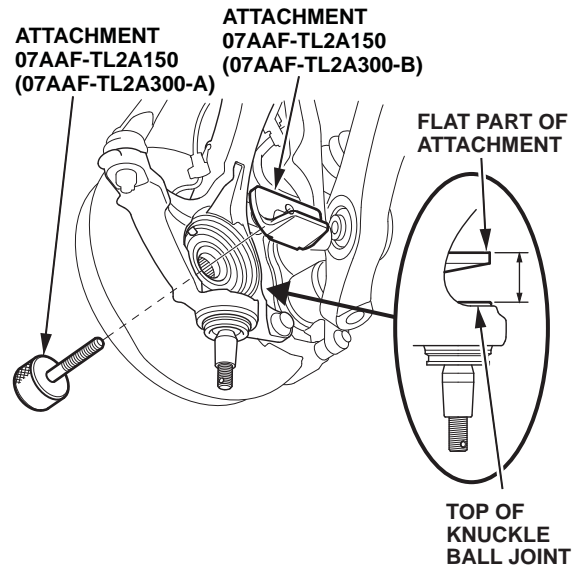

29. Position the ball joint tool kit, the adapter G, and the C-frame OTC7248 (commercially available) on to the knuckle ball joint.

NOTE: Make sure the attachments are installed securely.

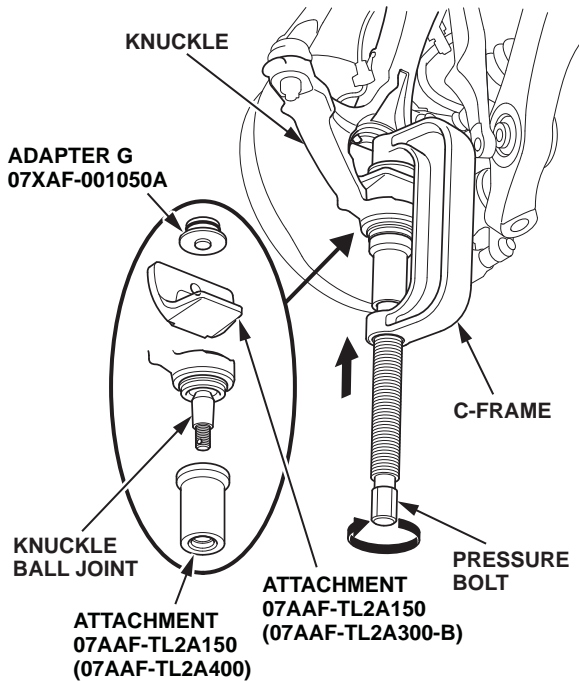

30. Tighten the pressure bolt of the C-frame, and remove the knuckle ball joint.

NOTE: When tightening the pressure bolt, secure the knuckle and the outboard joint.

31. Remove the ball joint tool attachments (07AAF-TL2A300-A and B) from the hub.

32. Set the ball joint into the knuckle.

NOTE: Confirm that the new lower ball joint is stamped with a letter P, indicating a part to resolve clunk noise in hot weather.

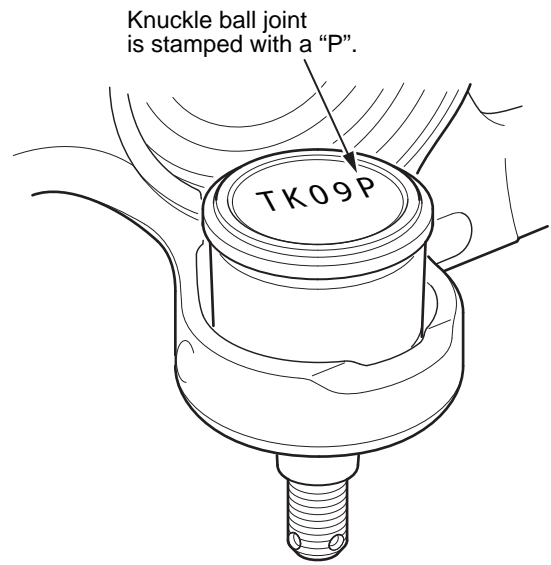

33. Position the ball joint tool kit and the C-frame, OTC7248, (commercially available) to the ball joint. Tighten the pressure bolt of the C-frame until the knuckle ball joint shoulder is fully seated in the knuckle.

NOTE: Make sure the attachments are installed securely. When tightening the pressure bolt, make sure the knuckle and the ball joint are properly aligned.

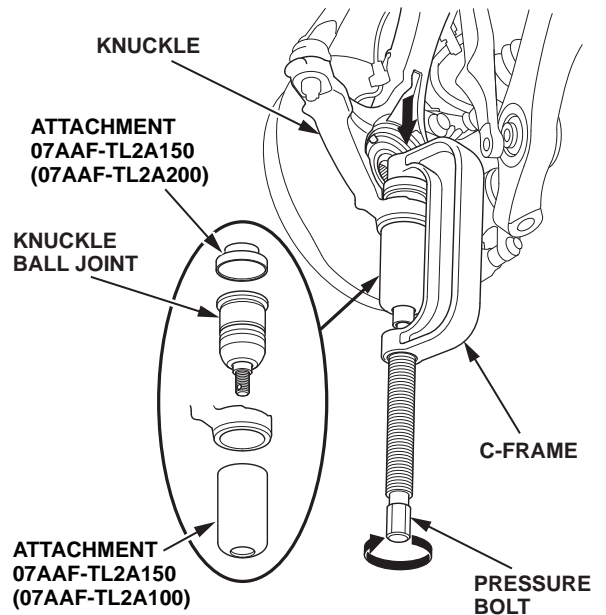

34. Using a yellow oil-based paint marker, paint the top of the knuckle lower ball joint.

NOTE: The paint mark is used to identify a knuckle that has had prior ball joint replacement. Always replace the knuckle as an assembly if the ball joint to be replaced has a paint mark.

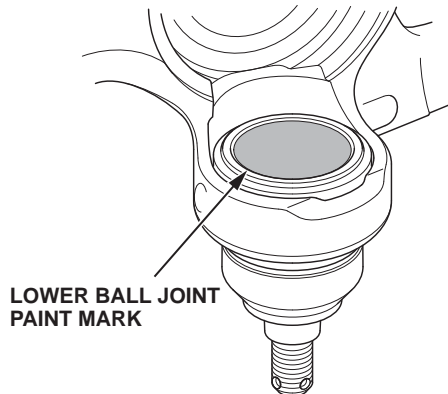

35. Install the remaining parts in reverse order of removal, and note these items:

- First, install all of the components, and lightly tighten the bolts and the nuts, then raise the suspension to load it with the vehicle's weight before fully tightening it to the specified torque. Do not place the jack against the ball joint pin of the knuckle.
- Be careful not to damage the ball joint boot when connecting the knuckle.
- Before connecting the ball joint, degrease the threaded section, the tapered portion of the ball joint pin, and the ball joint connecting hole, the threaded section, and the mating surfaces of the castle nut.
- Torque the castle nut to the lower torque specification, then tighten it only far enough to align the slot with the ball joint pin hole. Do not align the castle nut by loosening it.
- Use a new spindle nut on reassembly.
- Before installing the spindle nut, apply a small amount of engine oil to the seating surface of the nut. After tightening, use a drift to stake the spindle nut shoulder against the driveshaft.
- Before installing the wheels, clean the mating surfaces between the brake disc and the inside of the wheel.
- If the knuckle hub assembly was replaced, before installing the brake disc, clean the mating surfaces between the front hub and the inside of the brake disc.

36. Check the wheel alignment, and adjust it if necessary.