

**SB-10046861-8075**

SI B18 02 12  
Exhaust Systems

August 2012  
Technical Service

This Service Information bulletin supersedes SI 18 02 12 dated May 2012.

**PERFORM THE PROCEDURE OUTLINED IN THIS SERVICE INFORMATION BULLETIN ON ALL AFFECTED VEHICLES BEFORE CUSTOMER DELIVERY OR THE NEXT TIME THEY ARE IN THE SHOP FOR MAINTENANCE OR REPAIRS.**

**BMW centers must ensure recalls are completed after having been notified by BMW of North America, LLC (BMWNA) that a safety-related defect or noncompliance exists in any motor vehicle or item of replacement equipment in the center's possession at the time of notification. In BMW NA's case, this notification would typically be made by the issuance of a recall notification in the form of a Service Information bulletin (SIB) or transmission of a Dealer Communication System (DCS) recall message.**

**Under the National Traffic and Motor Vehicle Safety Act of 1966, as amended, if a recall campaign is announced by BMW NA, centers must ensure that all recalls on new vehicles and new items of replacement equipment are completed BEFORE delivery to the consumer. This means that centers may not legally deliver new motor vehicles or new items of replacement equipment to consumers with an open recall.**

**The Safety Act also prohibits centers from selling or leasing the motor vehicle or item of replacement equipment, unless and until the open recall has been completed BEFORE delivery. This also pertains to vehicles in the Certified Pre-Owned program, and to items of replacement equipment.**

**Finally, BMW centers should not sell or use parts that have been recalled by BMW NA. Please follow the specific instructions provided by BMW NA on the return or disposition of the parts.**

**NEW** designates changes to this revision

**SUBJECT**

**Voluntary Emissions Recall Campaign 11E-A03: Check and/or Replace Emissions Monitoring Components**

**MODEL**

E70 and E90 with the M57Y engine produced from January 2008 to September 2009

**SITUATION**

1. The Selective Catalyst Reduction (SCR) catalyst has been improved to increase emissions stability over the service life of the vehicle.
2. The SCR mixer has also been improved to optimize the Diesel Exhaust Fluid (DEF) mixture when introduced into the exhaust system.
3. Under certain driving conditions, the High-Pressure (HP) EGR valve may become restricted with

excessive soot. This restriction impedes the emissions performance of the HP EGR valve. This situation may lead to the Service Engine Soon lamp illuminating. An optimized EGR valve has been developed to limit this soot buildup.

Note: These improved parts may have already been replaced during a previous service visit. It will be necessary to inspect these components first before replacement.

4. Reprogramming of the DDE to optimize these improved emissions monitoring components.

#### AFFECTED VEHICLES

This Emissions Recall Campaign involves X5d and 335d models that were produced from January 2008 to September 2009.

In order to determine whether a specific vehicle has had this Emissions Recall Campaign completed or is affected by this Emissions Recall Campaign, first check if the “Emissions Recall Campaign Completed” label SD 92-435 is attached to the right (passenger) rear side of the hood in the engine compartment, close to the windshield. If the label is found, the campaign has already been performed. If the “Emissions Recall Campaign Completed” label is not present, it will be necessary to utilize the "Service Menu" of DCSnet (Dealer Communication System) or the Key Reader. Based on the response of the system, either proceed with the corrective action or take no further action.

#### CORRECTION

Inspecting the SCR catalyst:

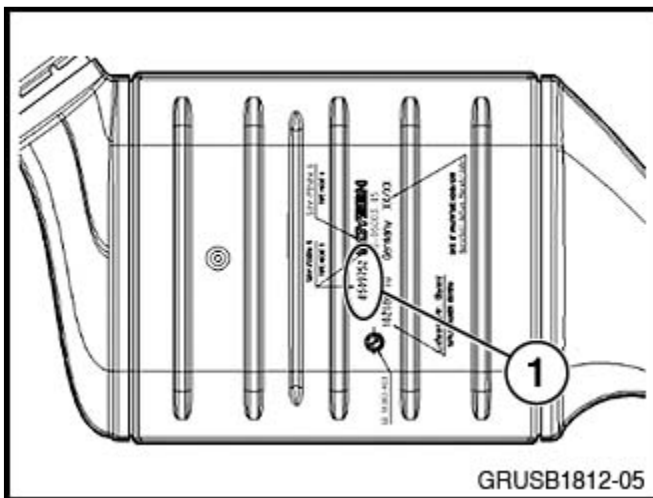

**NEW** Check the part number of the SCR catalyst (1). If the part number is not 18 30 8 509 752/753 (E70) or 18 30 8 509 749/750 (E90), the SCR catalyst will need to be replaced.

Note: If replacement is necessary, also perform the SCR mixer check/replacement at the same time.

Inspecting the mixer:

Remove the front pipe of the SCR catalyst to gain access to the mixer.

The original style mixer has a multiple

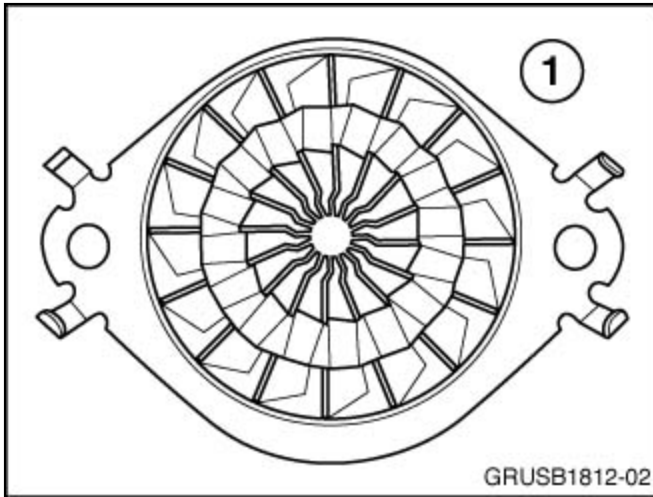

fin arrangement (1). This mixer will need to be replaced with P/N 18 30 8 513 445 (E70) or P/N 18 30 8 512 438 (E90).

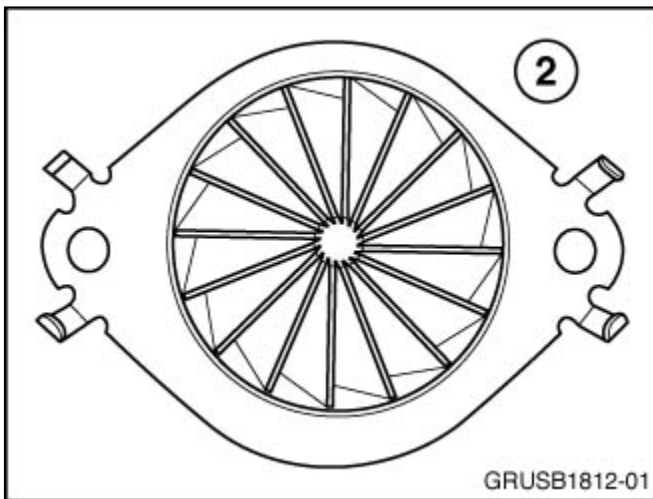

If the updated mixer has already been installed, it will have one set of fins (2). No replacement is necessary. Reinstall the SCR front pipe to the down pipe of the DPF.

Inspecting the EGR valve:

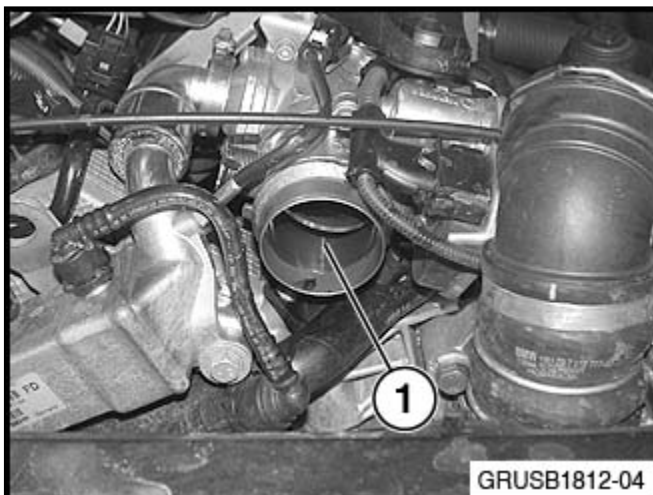

Remove the charge air pipe at the throttle (ignition off). Using a flashlight, look through the throttle (1) and inspect the EGR valve.

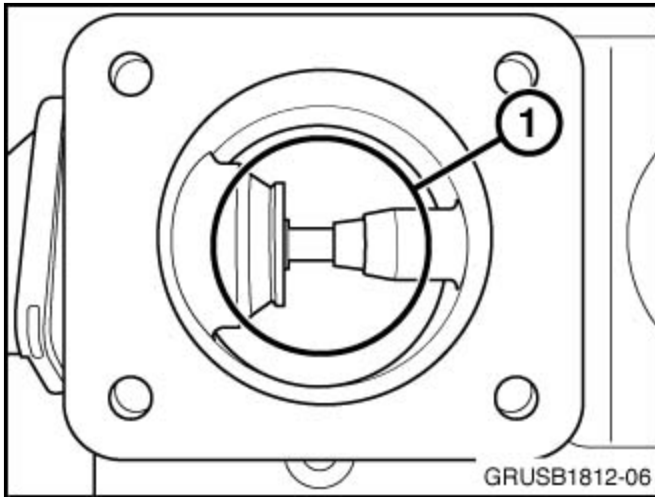

The updated EGR valve (P/N 11 71 8 517 217 or P/N 11 71 8 512 526) has the valve and seat directly in the airstream of the throttle (1). If this valve is installed, no further action is needed. Reinstall the charge air pipe.

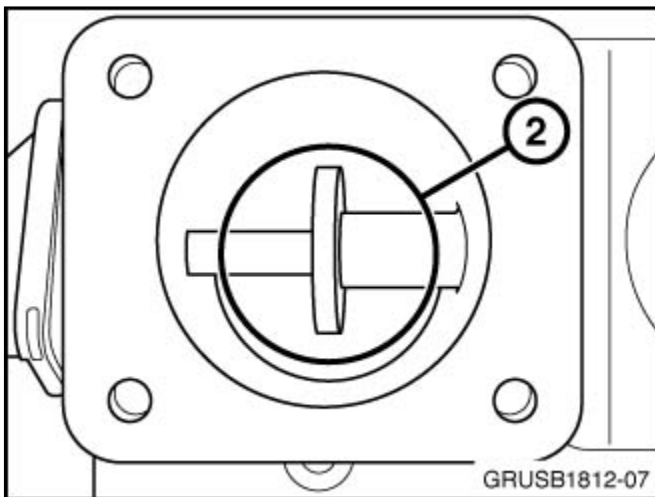

The original EGR valve has a diffuser in the airstream flow from the throttle (2). The valve for EGR actuation is seated further into the EGR airstream. Replace this valve with P/N 11 71 8 512 526 (Repair Instruction 11 71 501).

The DDE will also need to be programmed as part of the Recall. If the EGR valve is replaced, the DDE will need to be programmed after the new EGR valve is installed. This new software package contains the necessary software to adapt to the new EGR valve strategy.

Program the vehicle using ISTA/P 2.46.3 or later.

Note that ISTA/P will automatically reprogram and code all programmable control modules that do not have the latest software.

For information on programming and coding with ISTA/P, refer to CenterNet / Aftersales Portal / Service / Workshop Technology / Vehicle Programming.

#### **PARTS INFORMATION**

**Parts needed to perform inspection and/or replacement of the SCR catalyst, mixer and EGR valve:**

<b>Part Number</b>	<b>Description</b>	<b>Quantity</b>
11 62 7 509 731	Collar nut (exhaust)	2

18 30 7 812 171	Seal (exhaust)	2
07 14 6 954 889	Hexagon bolt with collar (E70)	4

**E70 (SCR catalyst, EGR valve and/or mixer replaced)**

SCR catalyst parts (if needed)

18 30 8 509 753	SCR catalyst	1
18 30 7 793 766	Clamp	1
18 30 7 560 781	Clamping sleeve	1

Mixer (if needed)

18 30 8 513 445	Mixer	1
-----------------	-------	---

EGR valve (If needed)

11 71 8 512 526	EGR valve	1
13 54 7 792 098	O-ring	1
11 61 2 245 439	Rubber seal	1

**E90 (SCR catalyst, EGR valve and/or mixer replaced)**

SCR catalyst parts (if needed)

18 30 8 509 750	SCR catalyst	1
18 30 7 560 779	Clamping sleeve	2

Mixer (if needed)

18 30 8 512 438	Mixer	1
22 11 6 775 521	Isa bolt with washer	2
11 62 7 620 549	Flanged hexagon nut	2

EGR valve (If needed)

11 71 8 512 526	EGR valve	1
18 20 8 511 880	Rubber mount	2
13 54 7 792 098	O-ring	1
11 61 2 245 439	Rubber seal	1

**LABEL INSTRUCTIONS**

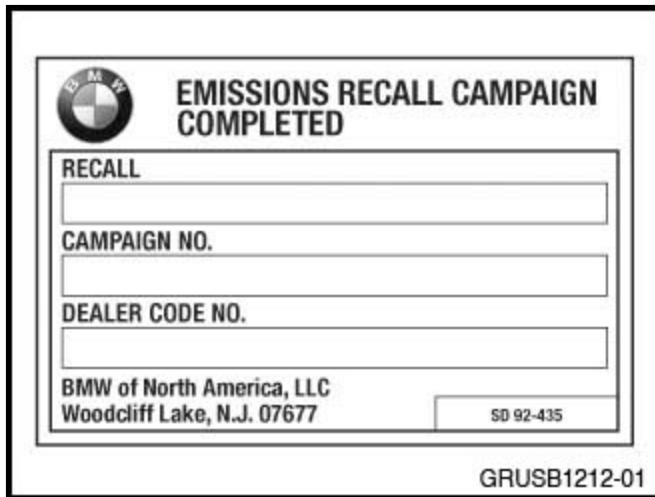

**EMISSIONS RECALL CAMPAIGN COMPLETED**

**RECALL**

**CAMPAIGN NO.**

**DEALER CODE NO.**

BMW of North America, LLC  
Woodcliff Lake, N.J. 07677

SD 92-435

GRUSB1212-01

After the vehicle has been checked and corrected, obtain a label (SD 92-435) and with the indelible marker provided, legibly print the Recall name, Recall number, and dealer code (5 digits) on the Recall Completion Label (see illustration). An initial quantity of **100** labels will be sent to all BMW centers. Peel the label from its backing and affix it to the right (passenger) rear side of the hood in the engine compartment, close to the windshield.

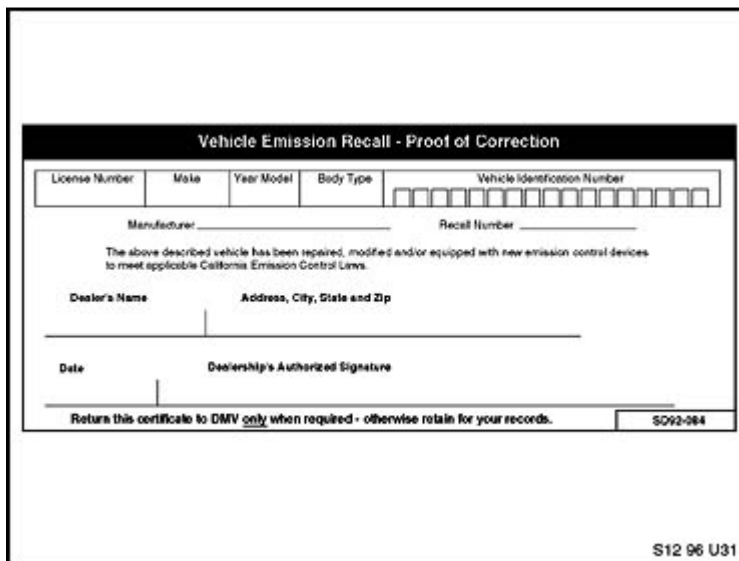

**Vehicle Emission Recall - Proof of Correction**

License Number	Make	Year Model	Body Type	Vehicle Identification Number
----------------	------	------------	-----------	-------------------------------

Manufacturer: \_\_\_\_\_ Recall Number: \_\_\_\_\_

The above described vehicle has been repaired, modified and/or equipped with new emission control devices to meet applicable California Emission Control Laws.

Dealer's Name: \_\_\_\_\_ Address, City, State and Zip: \_\_\_\_\_

Date: \_\_\_\_\_ Dealership's Authorized Signature: \_\_\_\_\_

Return this certificate to DMV only when required - otherwise retain for your records.

SD92-084

S12 96 U31

For California centers only: it is required by the California code of regulations that an executed orange "Vehicle Emission Recall - Proof of Correction" certificate (SD92-084, see illustration) be provided to each customer (for vehicles registered in the state of California), once the recall on his or her vehicle has been completed.

Note: additional labels can be ordered online at BMW TIS.

### WARRANTY INFORMATION

The repair described in this bulletin is covered under warranty regardless of time or mileage.

Reimbursement for this Recall will be via normal claim entry utilizing the information in the attachments for the E70 or E90 as applicable.

All the labor operation codes listed in the attachments are Main labor operations.

Refer to KSD2 for the corresponding flat rate unit (FRU) allowance. Enter the Chassis Number, which consists of the last 7 digits of the Vehicle Identification Number (VIN). Click on the "Search" button, and then enter the applicable flat rate labor operation in the FR code field.

If a control module fails to program correctly or initializations are required, the additional work must be claimed with separate labor operations under the defect code listed above, refer to KSD2.

**ATTACHMENTS**

view PDF attachment [B180212 Customer Letter](#).

view PDF attachment [B180212 Attachment E70](#).

view PDF attachment [B180212 Attachment E90](#).

[ Copyright © 2012 BMW of North America, LLC ]