



Service Bulletin

File in Section: -

Bulletin No.: PI0703B

Date: February, 2013

PRELIMINARY INFORMATION

Subject: Service Rear Axle Message Displayed on Driver Information Center (DIC), DTC C0407 with Symptom Code 64 or C0403 Symptom Code 62 Set

Models: 2010-2012 Buick LaCrosse
2010-2012 Cadillac SRX
Equipped with All-Wheel Drive (AWD)

This PI is being revised to add the Powertrain Coverage statement to the Warranty Information section. Please discard PI0703A.

Condition/Concern

Some customers may comment that the service rear axle message is displayed on the driver information center (DIC).

Note: GDS diagnostics must be used to confirm what DTC is set in the CCM.

When checking the vehicle for DTCs, the Rear Differential Clutch Control Module (CCM) may report either C0407 64 or C0403 62 set as current or in history.

Recommendation/Instructions

Important: Both the Cadillac SRX and the Buick LaCrosse will also require a calibration update to the clutch control module (CCM). Follow SI and TIS2WEB instructions to reprogram the CCM with the latest calibration available through TIS2WEB.

Important: It is very important that after the repairs are completed, the electronic limited slip differential (eLSD) clutch fluid fill and check procedure be followed exactly. Low fluid level can cause the DTC C0403 62 to repeat or induce DTC C0407 64. The unit MUST be filled with 350 ml of eLSD clutch fluid through the vent fitting opening (see Section III in this bulletin).

DTC C0403 Symptom 62:

The DTC C0403 symptom 62 may be set due to a concern with the torque transfer device (TTD) internal filter. To obtain a filter kit that will include a filter and gasket, please order parts currently available and listed in the parts section of this communication. Refer to the Differential Clutch Oil Filter Replacement procedure in SI.

DTC C0407 Symptom 64:

Important: The single biggest cause of a C0407 symptom 64 is low eLSD clutch fluid. Low eLSD clutch fluid may be caused by improper filling of the eLSD clutch, an internal piston seal leak or a leak at the pump cover gasket. The eLSD clutch MUST be filled with 140 ml (0.15 qts) of eLSD clutch fluid through the vent fitting opening in the TTD clutch cover and NOT the TTD clutch cover plug. For internal piston seal leaks, it is not necessary to replace the complete eLSD clutch assembly or the complete rear differential.

The C0407.64 code is set when the fluid is low in the TTD clutch. There are several conditions that can cause the eLSD clutch to be low on fluid:

- External leakages on the eLSD and TTD clutch (see Section I in this bulletin).
- Electronic limited slip eLSD clutch oil leaking into the rear differential through the electronic limited slip eLSD clutch piston seals (see Section II in this bulletin).
- Improper filling of the TTD clutch during the eLSD and TTD clutch filter/gasket service or pump replacement (see Section III in this bulletin).

Important: Replacing the control module or module kit WILL NOT correct this condition. Removing the control module and valve will purge some of the air from the pump motor cavity, which will give a false condition that a new control module was the correct repair.

Section I

Inspect the vehicle for external leakages. Below is a list of common leaks and suggestions for repair.

- Leak from the TTD clutch oil cover - retighten the bolts or replace the gasket and refill the eLSD clutch.
- Leak from the eLSD clutch pipes - replace the leaking fitting and reattach the pipe using a new clip. Refill TTD clutch.
- Leak from steel balls on the eLSD and TTD clutch - replace the eLSD or TTD clutch assembly.

Once a leak is corrected, the eLSD clutch oil level should be confirmed with the eLSD clutch Oil Inspection procedure in section III. The eLSD clutch is properly filled when fluid level is level with the bottom of the eLSD clutch cover plug and pump motor current is between 2.5-3.5A. Both conditions **MUST** be met for the TTD clutch to be considered full. Follow the fill process in Section III if fluid needs to be added.

Section II

If no external leakages are found, follow the instructions below to confirm an internal piston seal leak.

1. Check for rear differential fluid level being too high (overfilled). Use the Rear Axle Lubricant Level Inspection procedure in SI to check fluid level. The fluid level should be even with the bottom edge of the fill plug opening if not overfilled.
2. Confirm that either a) or b) exists.
 - a) eLSD clutch fluid level is low. Use the eLSD clutch oil inspection procedure in SI to check fluid level. Fluid level should be level with the bottom of the eLSD clutch cover plug when fluid level is not low.
 - b) eLSD clutch fluid level is OK, but the current of the eLSD clutch pump motor is consistently below 2.5A (differential clutch fluid level will NOT be OK if the pump motor current is consistently below 2.5A). Observe the current using the scan tool and monitoring the rear eLSD clutch pump motor current parameter. As the pump motor turns on/off, the current will cycle from 0A to 2.5-3.5A, if functioning normally.

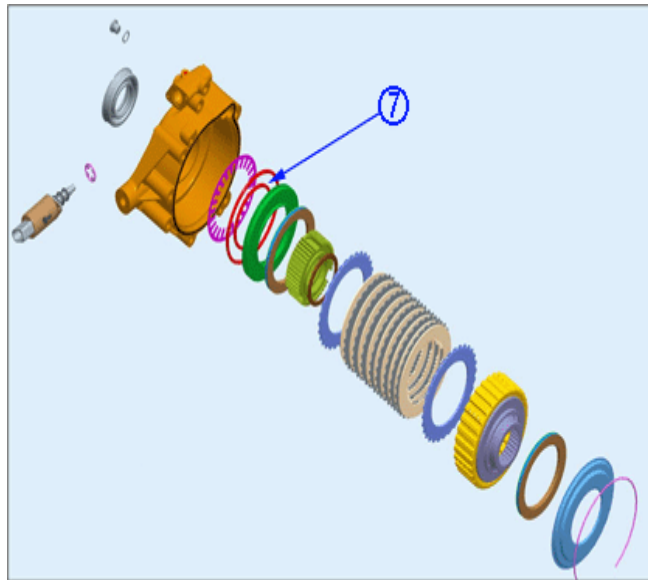

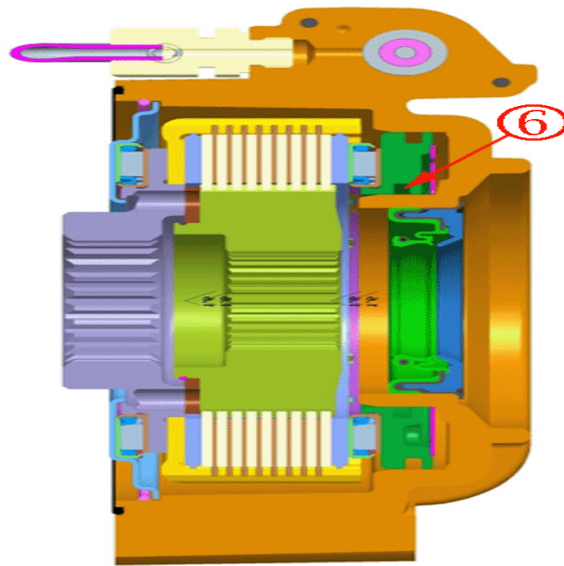

2549356

3. If the rear differential fluid level is too high and either a or b exists, then the eLSD clutch oil is leaking past the eLSD clutch internal piston seals (6 or 7) into the rear differential. The service fix is to replace the eLSD clutch piston only using the following procedure.

Electronic Limited Slip Differential Clutch Piston Replacement

Caution: It is very important to observe maximum cleanliness when working on the differential clutch. Dirt particles can seriously damage the function and service life of the differential clutch.

1. Raise the vehicle.
2. Drain the rear differential fluid.
3. Remove the rear axle assembly from the vehicle. Refer to the Differential Carrier Assembly Replacement procedure in SI.
4. Place the rear differential assembly on a clean work bench.

Warning: *The hydraulic pressure in the differential clutch is very high. To prevent personal injury, wait for at least 10 minutes before removing any parts from the differential clutch.*

5. Remove the limited slip differential clutch low and high pressure pipes from the differential clutch.
6. Remove the electrical connector from the limited slip differential valve and remove the harness from the clip.
7. Remove the limited slip differential clutch bolts (Qty: 6).
8. Remove the limited slip differential clutch from the differential carrier assembly.

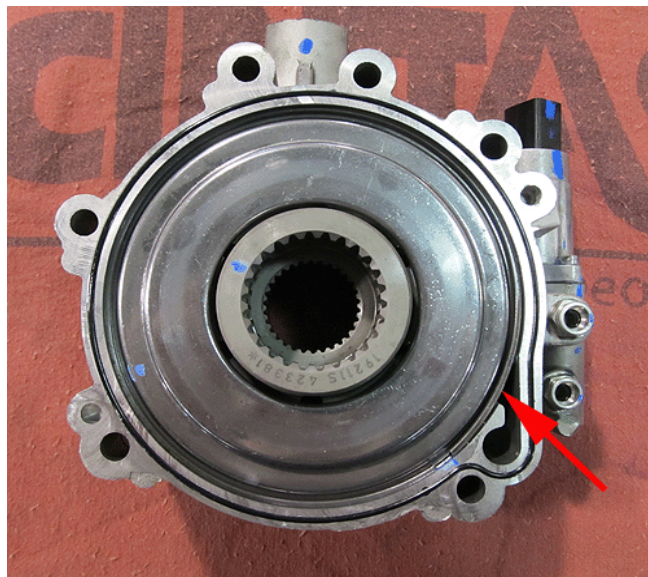

2789536

9. Remove the retaining ring that secures the differential clutch pack to the clutch housing.



2789542



2789543

10. Remove the differential clutch pack from the clutch housing. Hold the housing in one hand and flip over to allow the clutch pack to fall into the other hand.

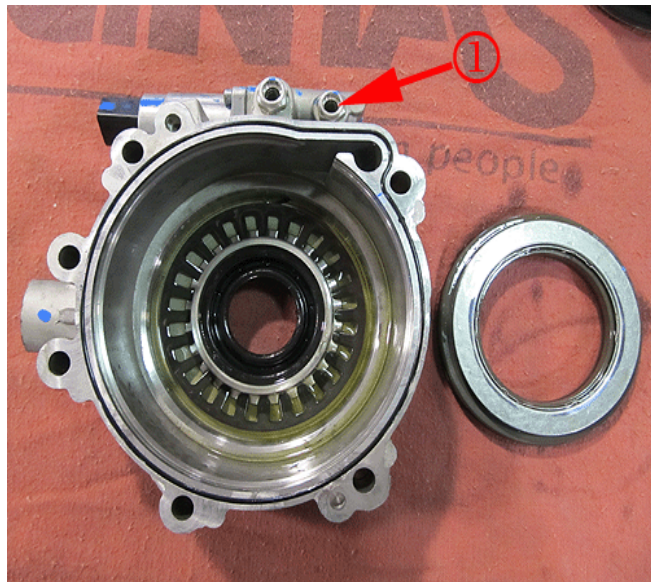

2789545



2806109

11. Apply compressed air to the low pressure pipe connector port to release the piston from the differential clutch housing.
12. Remove the eLSD clutch piston from the housing.



2789546

Note: If the piston spring is removed, ensure proper orientation when reinstalling. Spring fingers must be positioned as shown above.

13. Install the new eLSD clutch piston into the housing. Push down to seat.
14. Reinstall the differential clutch pack into the housing.
15. Reinstall the retaining ring that secures the differential clutch pack to the clutch housing.
16. Remove the low and high pressure pipe connectors from the limited slip differential clutch. Discard the connectors and pipe spring clips.
17. Install the NEW low and high pressure pipe connectors and spring clips to the limited slip differential clutch.

Tighten

Start by hand than tighten the connectors to 7 N•m (62 lb in).

18. Reinstall the limited slip differential clutch to the differential carrier assembly.

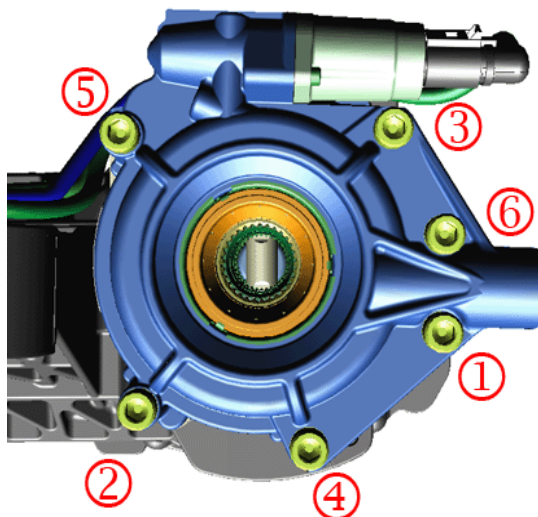

2806114

19. Reinstall the limited slip differential clutch bolts (Qty: 6).

Tighten

Tighten the bolts in proper sequence to 30 N•m (22 lb ft).

20. Reinstall the limited slip differential clutch low and high pressure pipes to the differential clutch.

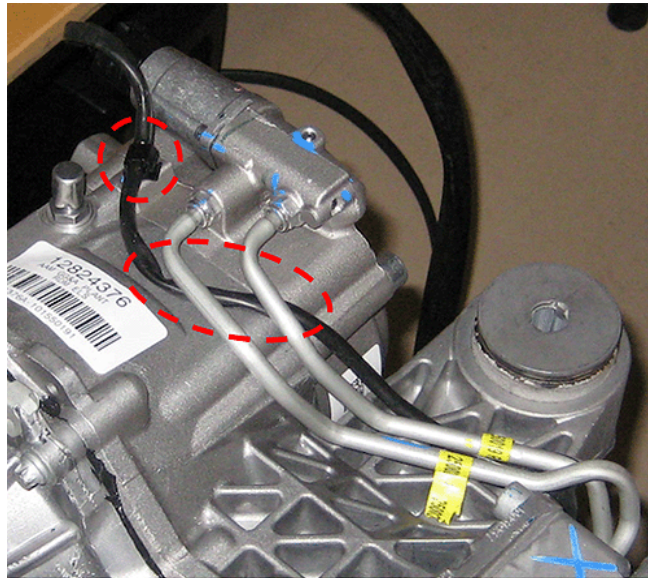

2806112

21. Reinstall the electrical connector to the limited slip differential valve and harness to the clip. Route the electrical harness under the pressure lines as shown.

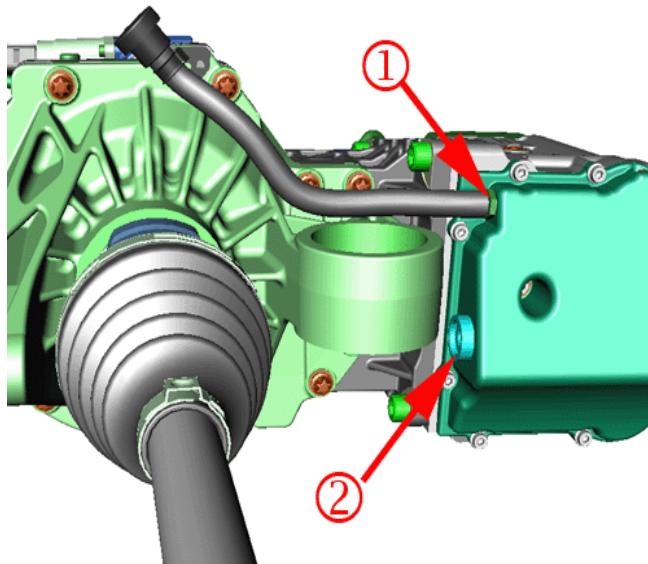

2806115

22. Remove the TTD clutch cover fill plug (2) and add 140 ml (0.15 qts) of eLSD clutch fluid. Install the fill plug and tighten to 14 N•m (10 lb ft).

Note: 140 ml (0.15 qts) if only the piston was replaced and 300 ml (0.32 qts) if the piston and filter were replaced. May be easier to get the required fluid into the unit if the assembly is tilted up on the pinion nose.
23. Install the rear axle assembly to the vehicle. Refer to the Differential Carrier Assembly Replacement procedure in SI.
24. Refill the differential rear axle. Refer to the Differential Rear Axle Lubricant Level Inspection in SI.
25. Lower the vehicle.
26. Start the vehicle and allow running for 5 minutes at idle.
27. In Park, cycle the throttle from idle to wide open throttle briefly 5 times waiting a minimum of 30 seconds between each WOT cycle to cycle solenoids to purge air.
28. With the engine running, observe the scan tool rear limited slip differential clutch pump motor current parameter. The parameter display should be above 2.5A when the pump is on. If the current is below 2.5A, then shut the vehicle off and recheck the level by performing steps 29 through 33.
29. To stabilize the clutch oil level, let the vehicle rest 10 minutes with the ignition off.
30. Raise the vehicle and support the vehicle.
31. Remove the differential clutch cover plug (2) and recheck the differential clutch fluid level.

32. The eLSD clutch fluid should be level with the bottom of the eLSD clutch cover plug hole (2). If the eLSD clutch is overfilled, drain out fluid until it is at the proper level. Add fluid through the vent opening (1) if the eLSD clutch is low on fluid.
33. Install the TTD clutch cover plug (2) and re-tighten to 14 N•m (10 lb ft).
34. Lower the vehicle.
35. Drive the vehicle 10 km (6 mi) to confirm that the DTC does not reset.

Section III

If improper filling is suspected or a leak is corrected, follow the instructions below to check and properly fill the TTD clutch fluid.

The TTD clutch is properly filled when the fluid level is level with the bottom of the TTD clutch cover plug and the pump cavity (4) is full. The pump cavity is full when the pump motor current is between 2.5-3.5A while the engine is running and the pump motor is running. The current cycles from 0 to 2.5-3.5A as the pump turns off/on. Both conditions MUST be met. If the pump motor current is consistently below 2.5A, then the pump motor cavity (4) is low on fluid.

Important: When filling the eLSD clutch housing after repairs, the fluid must be able to flow over the top of the internal wall of the pump cavity (3 and 4), making it imperative that the fluid is filled through the vent opening (1) with the cover plug (2) installed. The bottom of the cover plug opening (2) and the internal wall (3) are at the same level. If the cover plug (2) is not installed, the fluid will fill the eLSD clutch oil sump (5) and run out of that opening (2) before it can flow over the wall (3) into the pump cavity (4).

If the clutch fluid level is level with the bottom of the eLSD clutch cover plug (Fig. 3, B) and the pump motor current is below 2.5A, then the eLSD clutch pump cavity is empty.

If this is the case, the TTD clutch needs to have fluid added using the following procedure:

1. Clear all DTCs.
2. Raise the vehicle and support the vehicle.

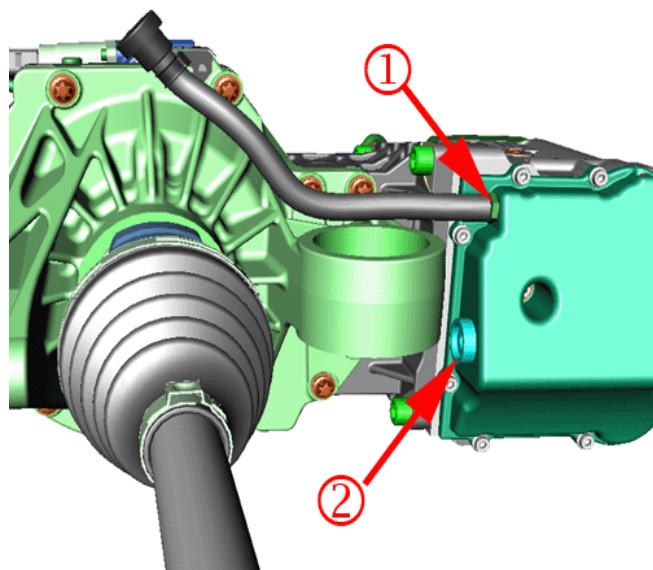

2806115

3. Remove the vent hose (1) from the fitting.
4. Attach the fill hose to the vent fitting and fill the TTD clutch through the vent opening on the cover. Ensure that the fill plug (2) is installed prior to adding fluid through the vent fitting.
5. Install the vent hose.
6. Lower the vehicle.
7. To stabilize the oil level, let the vehicle rest 10 minutes with the ignition off.
8. Start the engine and allow to run for 5 minutes at idle.
9. In Park, cycle the throttle from idle to wide open throttle briefly 5 times waiting a minimum of 30 seconds between each WOT cycle to cycle solenoids to purge air.
10. With the engine running, observe the scan tool rear limited slip differential clutch pump motor current parameter. If the parameter display is above 2.5A when the pump is on, then go to Step 11. If the current is below 2.5A, then shut the engine off and go back to Step 1.
11. Shut the engine off.
12. Raise the vehicle and support the vehicle.

13. Remove the differential clutch cover plug (2) and inspect the differential clutch fluid level.
14. The differential clutch fluid should be level with the bottom of the eLSD clutch cover plug hole (2). If the eLSD clutch is overfilled, drain out fluid until it is at the proper level. Add fluid through the vent opening (1) if the TTD clutch is low on fluid.
15. Install the TTD clutch cover plug (2) and re-tighten to 14 N•m (10 lb ft).
16. Lower the vehicle.
17. Drive the vehicle 10 km (6 mi) to confirm that the DTC does not reset.

See Techlink article dated October 2010 for further details regarding the rear eLSD clutch system features and operation.

Parts Information

Part Number	Description
22956728	eLSD Clutch Piston Kit
20986573	Filter Kit, Differential Clutch Oil
88863349 (In Canada, use 88863350)	Differential Clutch Fluid
88900401 (In Canada, use 89021678)	Differential Rear Axle Fluid
88900330 (In Canada, use 992694)	Rear Axle Limited Slip Fluid (Additive)

Warranty Information

For vehicles repaired under the U.S. (5 years/100,000 miles or Canadian (5 years/160,000 km) Powertrain Warranty, use:

Labor Operation	Description	Labor Time
F9742*	Replace eLSD Clutch Piston and Reprogram Clutch Control Module (CCM)	4.6 hrs
F9731* (LaCrosse)	Replace eLSD Clutch Oil Filter and Reprogram Clutch Control Module (CCM)	1.7 hrs
F9731* (SRX)		1.5 hrs

*This is a unique labor operation for bulletin use only. It will not be published in the Labor Time Guide.