

ATTENTION:

- GENERAL MANAGER
- PARTS MANAGER
- CLAIMS PERSONNEL
- SERVICE MANAGER

IMPORTANT - All Service Personnel Should Read and Initial in the boxes provided, right.



QUALITY DRIVEN® SERVICE

SERVICE BULLETIN

APPLICABILITY: 2012-13MY Impreza 2.0L Models
2013MY XV Crosstrek

NUMBER: 12-157-13R

DATE: 10/28/13

SUBJECT: Rattle or Buzzing Sound from “A” Pillar Trim

REVISED: 11/27/13

INTRODUCTION

This bulletin provides a repair procedure to address a customer concern of a rattle or buzzing-type sound coming from the lower portion of the “A” pillar trim while driving over bumpy or rough road surfaces. The lower insertion claws and / or the trim’s support rib may be coming in contact with the vehicle body causing the sound.

COUNTERMEASURE IN PRODUCTION

Non-woven fabric tape has been applied to the “A” pillar trim in production from February 1, 2013.

PART INFORMATION

PART NAME	PART NUMBER	QUANTITY
Non-Woven Tape (.43mm thick)	SOA963W110	1 (8”x11” sheet)
Tether Clip	909150034	1 per side

SERVICE PROCEDURE / INFORMATION

- Using a plastic trim tool, **CAREFULLY** pry loose and remove the tweeter speaker grille from the dash as shown in the photo below.



Continued...

CAUTION: VEHICLE SERVICING PERFORMED BY UNTRAINED PERSONS COULD RESULT IN SERIOUS INJURY TO THOSE PERSONS OR TO OTHERS.

Subaru Service Bulletins are intended for use by professional technicians ONLY. They are written to inform those technicians of conditions that may occur in some vehicles, or to provide information that could assist in the proper servicing of the vehicle. Properly trained technicians have the equipment, tools, safety instructions, and know-how to do the job correctly and safely. If a condition is described, DO NOT assume that this Service Bulletin applies to your vehicle, or that your vehicle will have that condition.

SUBARU OF AMERICA, INC. IS “ISO 14001 COMPLIANT”

The international standard for excellence in Environmental Management Systems. Please recycle or dispose of automotive products in a manner that is friendly to our environment and in accordance with all local, state and federal laws and regulations.

- Remove the “A” pillar trim following the procedure in the applicable Service Manual. Cut the tether clip shown in the photo below as it is a 1-time use item and must be replaced.

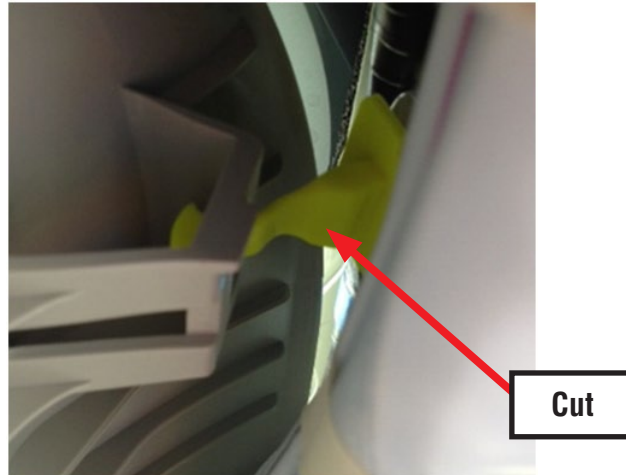

- With the “A” pillar trim at room temperature, clean the 3 areas shown in the illustration below (A, B, and C) with rubbing alcohol applied to a clean shop cloth then allow to dry before installing the non-woven material.

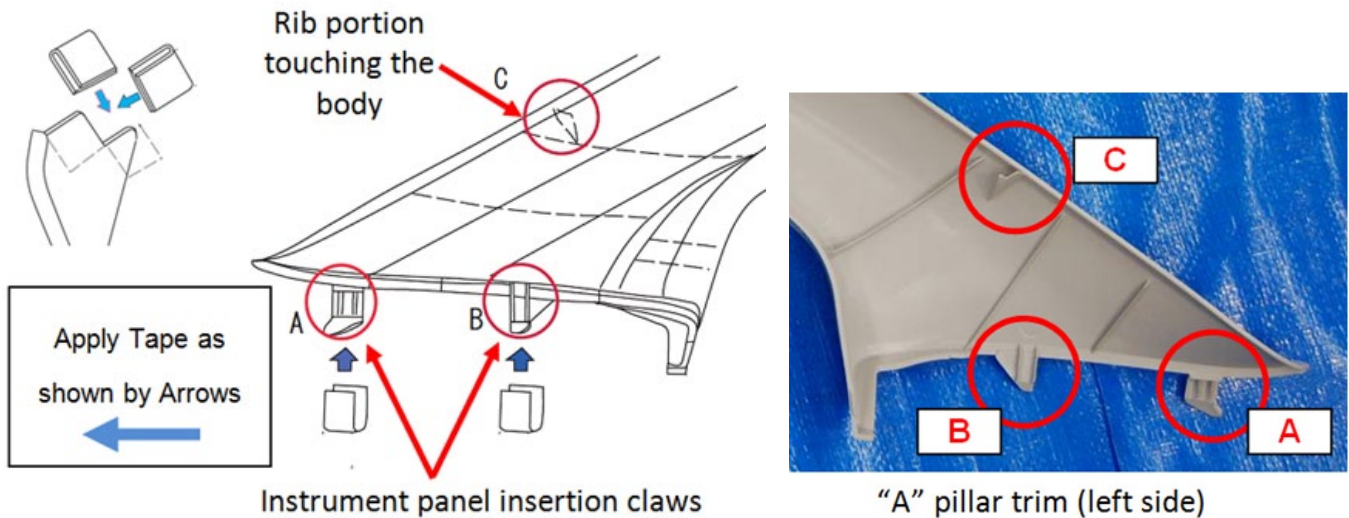

- Cut the non-woven material pieces to size then peel the adhesive backing and apply to the insertion claws and rib portion as shown in the illustration below.

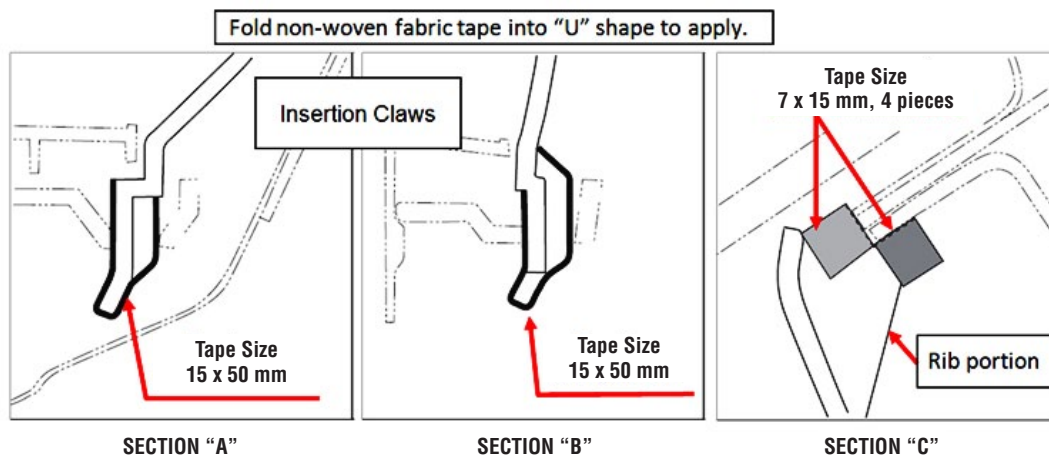

Continued...

- For section C, the material must be doubled (2 layers thick) to achieve the required thickness as shown in the photo below.

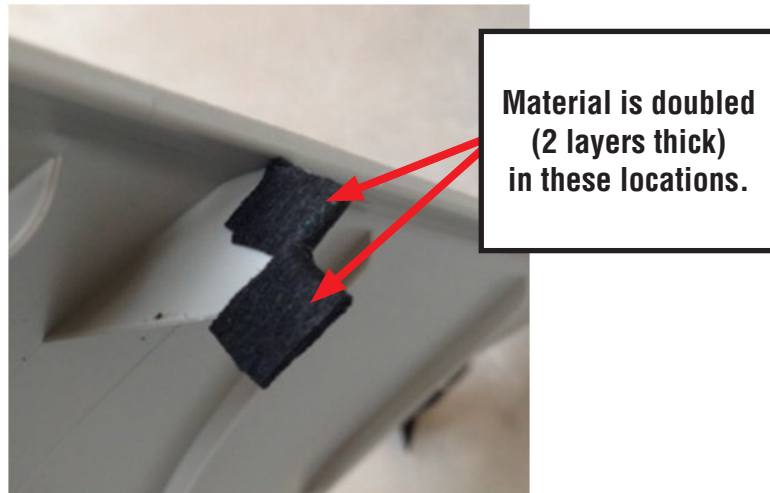

- Once all the non-woven material pieces are in place, re-install the “A” pillar trim using a **NEW** tether clip.

IMPORTANT: The tether clips are **one-time use items** and **must** be replaced any time they are removed. Additionally, the tether clip must be installed into the “A” pillar trim in the proper direction. See the photo and illustrations below for proper installation details.

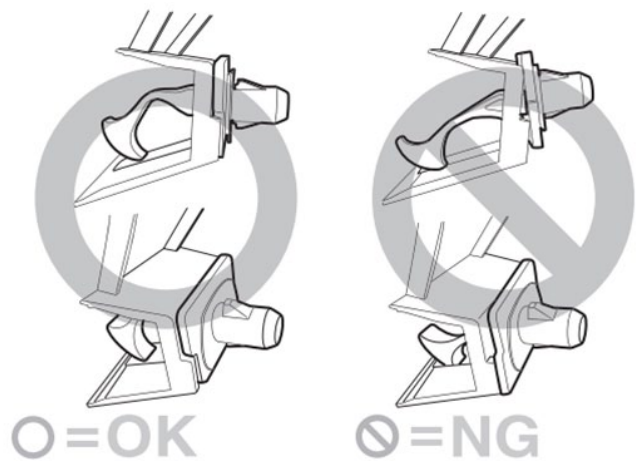
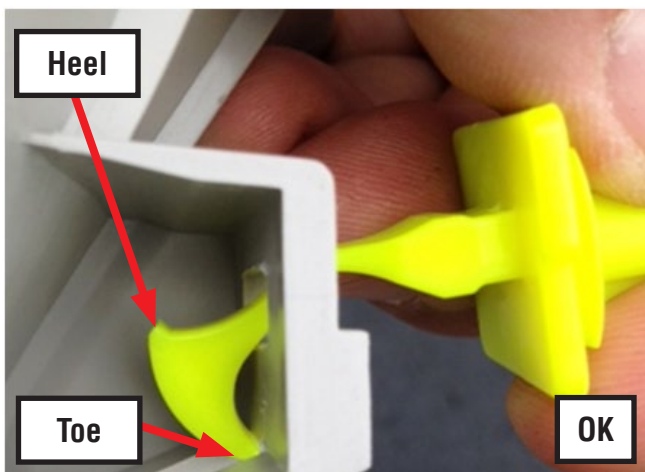

WARRANTY / CLAIM INFORMATION

For vehicles within the Basic New Car Limited Warranty period, this repair may be claimed using the following information:

LABOR DESCRIPTION	LABOR OPERATION #	FAIL CODE	LABOR TIME
"A" Pillar Modification (1 side)	A913-171	YCJ-48	0.2

NOTE: For claim submission purposes, use part number SOA635079, qty. 1 per side repaired.

SOA635079 is for claim submission only and can not be ordered.