



NUMBER: 19-001-13 REV. A

GROUP: Steering

DATE: June 11, 2013

This bulletin is supplied as technical information only and is not an authorization for repair. No part of this publication may be reproduced, stored in a retrieval system, or transmitted, in any form or by any means, electronic, mechanical, photocopying, or otherwise, without written permission of Chrysler Group LLC.

THIS BULLETIN SUPERSEDES SERVICE BULLETIN 19-001-13, DATED MAY 31, 2013, WHICH SHOULD BE REMOVED FROM YOUR FILES. ALL REVISIONS ARE HIGHLIGHTED WITH **ASTERISKS**** AND INCLUDE AN ADDITIONAL LABOR OPERATION.**

THIS SERVICE BULLETIN IS ALSO BEING RELEASED AS RAPID RESPONSE TRANSMITTAL (RRT) 13-041. ALL APPLICABLE SOLD AND UN-SOLD RRT VIN'S HAVE BEEN LOADED. TO VERIFY THAT THIS RRT SERVICE ACTION IS APPLICABLE TO THE VEHICLE, USE VIP OR PERFORM A VIN SEARCH IN TECHCONNECT. ALL REPAIRS ARE REIMBURSABLE WITHIN THE PROVISIONS OF WARRANTY.

SUBJECT:

Rattle From Driver Side Of Instrument Panel Or Steering Wheel Over Rough Roads Or When Turning

OVERVIEW:

This bulletin involves diagnosing and if necessary removing the steering column lock control module wiring harness bracket.

MODELS:

2014 (WK) Grand Cherokee (Includes SRT8)

NOTE: This bulletin applies to vehicles built on or after January 22, 2013 (MDH 0122XX and on or before March 26, 2013 (MDH 0326XX) equipped without (sales code CXE) electric steering column shaft lock.

SYMPTOM/CONDITION:

Rattle from driver side of instrument panel or steering wheel over rough roads or when turning.

DIAGNOSIS:

If a customer's VIN is listed in VIP or your RRT VIN list, perform the repair. For all other customers that describe the symptom/condition, perform the Repair Procedure.

REPAIR PROCEDURE:

1. **Inspect the vehicle for the steering column lock control module wiring harness bracket (Fig. 1). Is the steering column lock control module wiring harness bracket installed?
 - a. Yes>>> Proceed to [Step #2](#).
 - b. No>>> Return the vehicle to the customer or dealer inventory. **

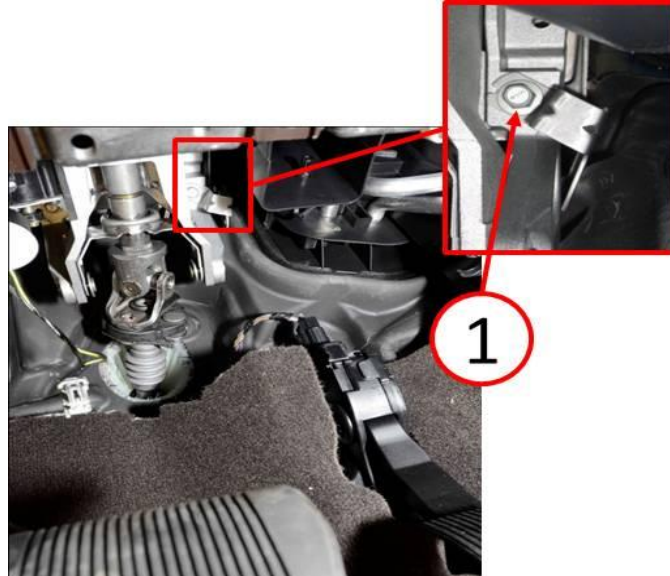

Fig. 1 Steering Column Bracket

1 - Steering Column Lock Control Module Wiring Harness Bracket Fastener

2. Release the fasteners securing the driver side instrument panel closeout (1) to the instrument panel ([Fig. 2](#)).



Fig. 2 Left Instrument Panel Closeout

1 - Left Instrument Panel Closeout

-
3. Disconnect the courtesy lamp electrical harness (1) from the driver side instrument panel closeout (2) ([Fig. 3](#)).
 4. Remove the driver side instrument panel closeout (2) from the vehicle ([Fig. 3](#)).

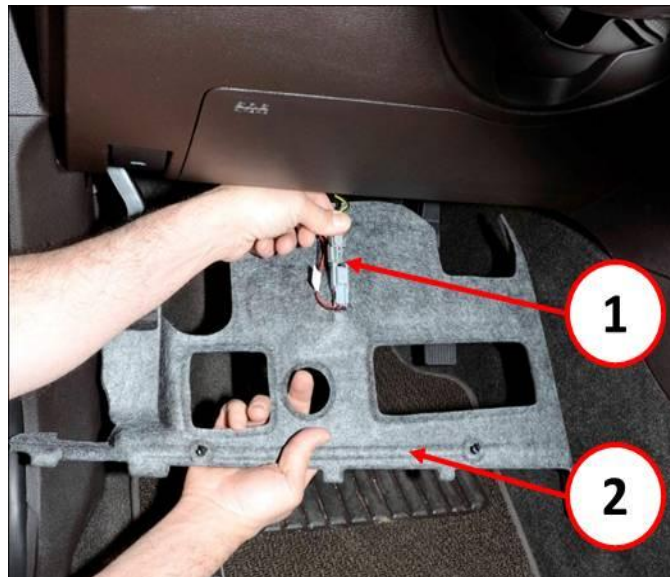

Fig. 3 Instrument Panel Closeout Removal

1- Courtesy Lamp Harness

2- Left Instrument Panel Closeout

5. Remove the fastener (1) securing the steering column lock control module wiring harness bracket to the steering column and discard the steering column lock control module wiring harness bracket (Fig. 4).

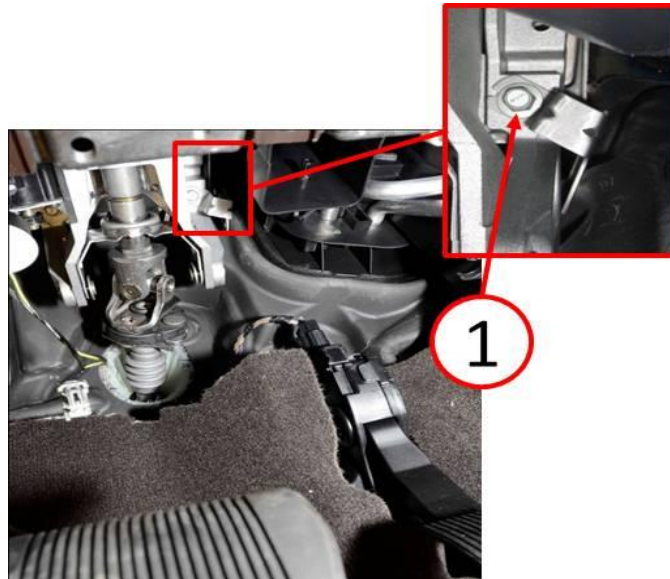

Fig. 4 Steering Column Bracket

1 - Steering Column Lock Control Module Wiring Harness Bracket Fastener

6. Reinstall the fastener that secured the steering column lock control module wiring harness bracket to the steering column and torque to 27 N-m (20 ft-lbs).
7. Connect the courtesy lamp electrical harness (1) to the driver side instrument panel closeout (2) (Fig. 3).
8. Install the driver side instrument panel closeout (2) to the vehicle (Fig. 2).

POLICY:

Reimbursable within the provisions of the warranty.

TIME ALLOWANCE:

Labor Operation No:	Description	Amount
19-20-67-90	Inspect and remove the steering column lock control module wiring harness bracket (0 - Introduction)	0.2 Hrs.
19-20-67-91	Inspect for steering column lock control module wiring harness bracket only (0 - Introduction)	0.2 Hrs.

FAILURE CODE:

ZZ	Service Action
----	----------------