

# TECHNICAL BULLETIN

J028NAS2  
10-JAN-13



ISSUE '2' CHANGES ARE HIGHLIGHTED IN GRAY

## SECTION: 418

### Safety Recall: Fuel Starvation

#### AFFECTED VEHICLE RANGE:

XF (X250)

VIN: **S55273-S63550** (specific VINs only; see attached list)  
Model Year: **2013**

#### CONDITION SUMMARY:

**Situation:** A concern has been identified on a limited number of XF vehicles where the engine may not start or may start and then cut out while in motion as a result of the in-tank electric fuel pump not being correctly activated during the vehicle start-up cycle.

**Action:** Retailers are required to before sale **HOLD** all affected vehicles in the above VIN range that are in their control and refrain from releasing the vehicles for new or used vehicle sale pending completion of the rework action detailed in this Technical Bulletin.

#### PARTS:

PART NO.	DESCRIPTION	QTY	% OF VEHICLES REQUIRING PART*
C2Z26797	Link lead harness kit	1	100

\* when ordering parts, order the expected percentage failure rate of parts identified only

#### TOOLS:

Refer to the Workshop Manual / Repair Procedure for any required special tools

#### WARRANTY:

 **NOTE:** Repair procedures are under constant review, and therefore times / prices are subject to change; those quoted here must be taken as guidance only. Always refer to DDW to obtain the latest repair time. Check DDW to ensure that the vehicle is affected by this program prior to undertaking any rework action. At the time of confirming a booking for vehicle repair, ensure that all outstanding Service Actions are identified to ensure the correct parts are available and adequate workshop time is allocated for repairs to be completed at one visit.

Warranty claims must be submitted quoting Program Code '**J028**' together with the relevant Option Code from the table. The SRO and part information listed have been included for information only. The Option Code(s) that allows for the drive in / drive out allowance can only be claimed if the vehicle is brought back into the workshop for this action alone to be undertaken.

PROGRAM CODE	OPTION CODE	DESCRIPTION	SRO	TIME (HOURS)	PART No.	QTY. / VALUE
<b>J028</b>	<b>B</b>	Install overlay harness	86.94.78	0.40	C2Z26797	1
<b>J028</b>	<b>C</b>	Install overlay harness Drive in/drive out	86.94.78 10.10.10	0.40 0.10	C2Z26797 -	1 -

*Normal Warranty policies and procedures apply*

NOTE: The information in Technical Bulletins is intended for use by trained, professional Technicians with the knowledge, tools, and equipment required to do the job properly and safely. It informs these Technicians of conditions that may occur on some vehicles, or provides information that could assist in proper vehicle service. The procedures should not be performed by 'do-it-yourselfers'. If you are not a Retailer, do not assume that a condition described affects your vehicle. Contact an authorized Jaguar service facility to determine whether this bulletin applies to a specific vehicle.

## **REPAIR PROCEDURE**

1. **⚠ CAUTION: Make sure that accidental re-connection is not possible.**

Refer to Workshop Manual section 414-01 and disconnect the battery ground cable.

2. Refer to Workshop Manual section 501-05 and remove the Loadspace Scuff Plate Trim Panel.

3. **△ NOTE: Left-hand (LH) shown; right-hand (RH) similar.**

Re-position the RH loadspace trim panel to gain access to the Body Control Module - Back (BCMB) / Auxiliary Junction Box (AJB).

- Remove the two (2) clips.

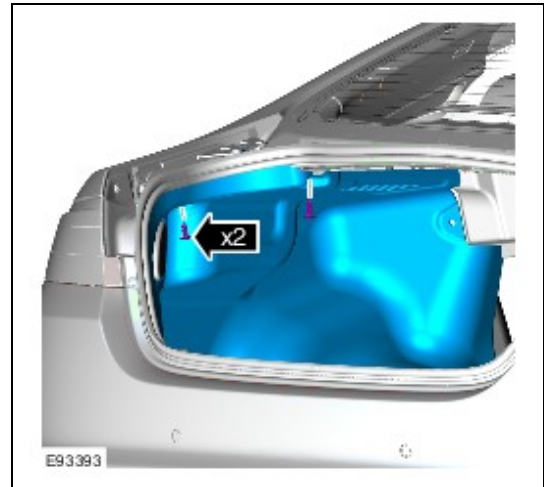

4. Disconnect the connector.

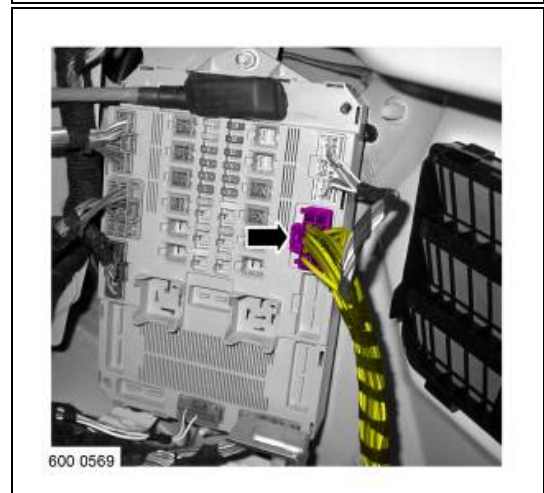

5. Install the new link lead and relay harness.
- Connect the two (2) connectors.

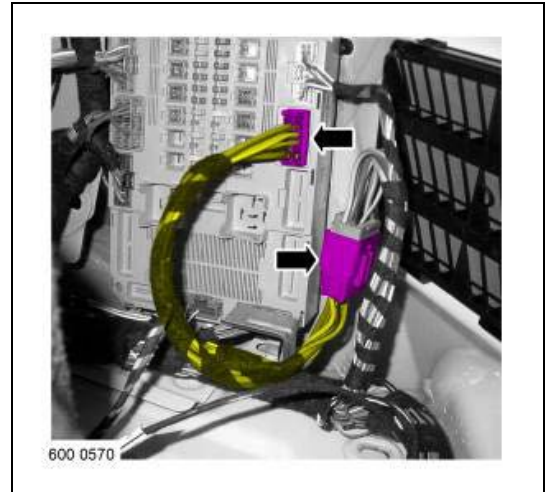

6. Secure the M8 eyelet to the battery cable connection.
- Feed the new harness along the existing harnesses in the position shown.
  - Re-position the battery cable connection cover.
  - Remove the nut.
  - Install the M8 eyelet on the stud.
  - Tighten the nut to 12 Nm.
  - Re-position the battery cable connection cover over the connection.

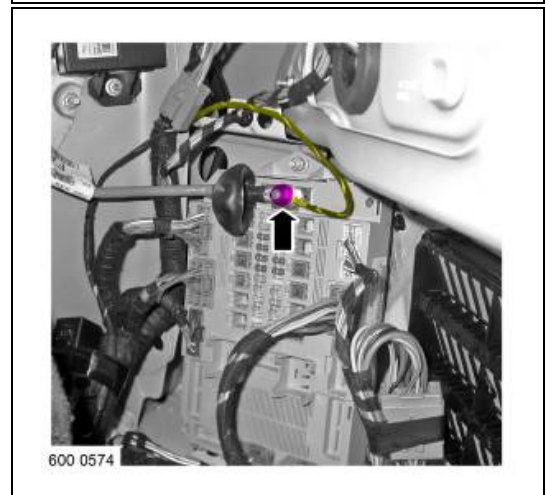

7. Using a suitable tape, secure the new link lead and relay harness to the existing harnesses in the positions shown.

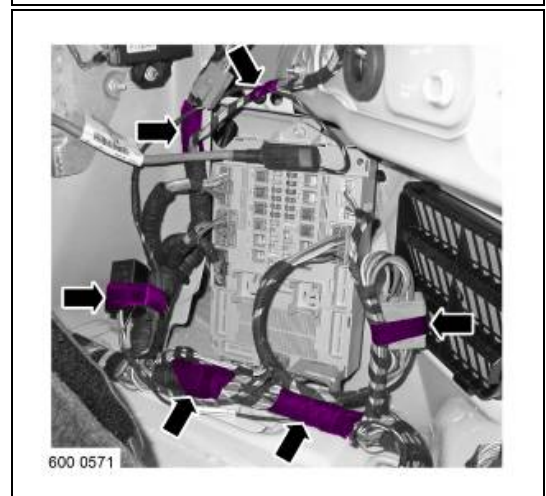

8. Secure the ground cable connection.
- Carefully feed the M6 eyelet along the underside of the existing harness to the LH-side of the luggage compartment.
  - Using a thread-cutting bolt, secure the ground cable in the position shown.
  - Tighten the bolt to 11 Nm.

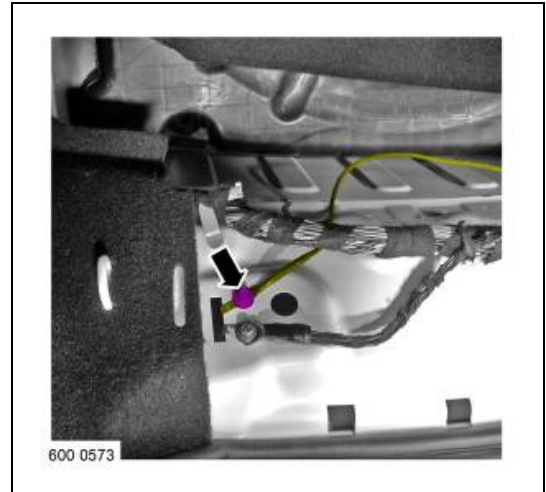

9. **⚠ CAUTION: Make sure that the ground cable is fully secured in the area of the luggage compartment lid latch, so that the ground cable cannot come in to contact with the latch. Failure to follow this instruction may result in damage to the vehicle.**

Using suitable tape, secure the ground cable to the underside of the existing harness at suitable points along the rear panel of the luggage compartment.

- Fully secure the ground cable to the existing harness in the area directly below the luggage compartment lid latch.



10. Using a suitable tape, secure the foam to the connector.

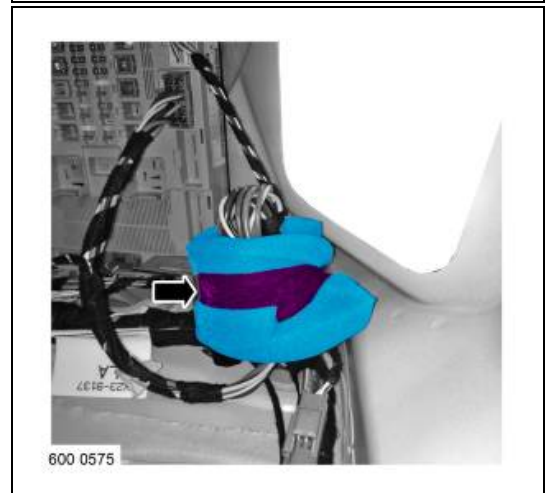

11.  **NOTE: Left-hand shown; right-hand similar.**  
Secure the RH loadspace trim panel.
- Secure the two (2) clips.

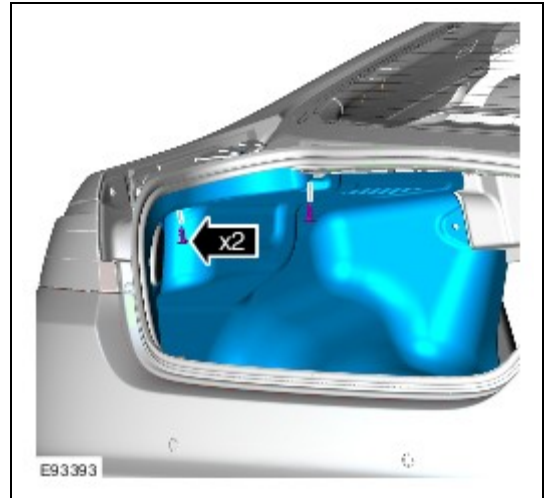

12. Refer to Workshop Manual section 501-05 and install the Loadspace Scuff Plate Trim Panel.
13. Refer to Workshop Manual section 414-01 and connect the battery ground cable.

## Safety Recall J028: Affected VIN List

---

RETAILER CODE / NAME	VIN
0517 British Motor Car Distributors, Ltd.	S63284
0617 Jaguar Minneapolis	S62664
5302 Jaguar Paramus	S63137
5395 Jaguar West Ashley	S63082
5429 Jaguar Roanoke	S63127
5533 Jaguar Hilton Head	S62870
5662 Leith Jaguar	S63175
5703 Galpin Jaguar	S63295
5799 Jaguar Schererville	S63262