

TECHNICAL BULLETIN  
Q332NAS1  
18 DEC 2013



© Jaguar Land Rover North America, LLC

NOTE: The information in Technical Bulletins is intended for use by trained, professional Technicians with the knowledge, tools, and equipment required to do the job properly and safely. It informs these Technicians of conditions that may occur on some vehicles, or provides information that could assist in proper vehicle service. The procedures should not be performed by 'do-it-yourselfers'. If you are not a Retailer, do not assume that a condition described affects your vehicle. Contact an authorized Land Rover service facility to determine whether this bulletin applies to a specific vehicle.

**SECTION: 414-01**

Service Action: Battery Retention

**AFFECTED VEHICLE RANGE:**

**Range Rover Sport (LW)**

**Model Year:** 2014  
**VIN:** EA301150-EA304822

**Range Rover Sport (LW)**

**Model Year:** 2014  
**VIN:** EA000001-EA001229

**Range Rover (LG)**

**Model Year:** 2013  
**VIN:** DA000001-DA001235

**Range Rover (LG)**

**Model Year:** 2013-2014  
**VIN:** DA100000-EA131231

**MARKETS:**

NAS

**CONDITION SUMMARY:**

**Situation:** An issue has been identified regarding battery retention on 2013-2014 model year Range Rover and 2014 model year Range Rover Sport vehicles.

**Action:** Retailers are required to **HOLD** all affected vehicles within the listed VIN range that are in their control and refrain from releasing the vehicles for new or used vehicle sale pending completion of the rework action detailed in this Technical Bulletin. Unsold vehicles should have this performed as part of the Pre-Delivery Inspection (PDI) process. Affected vehicles already in the hands of customers should be updated at the next available opportunity.

**PARTS:**

DESCRIPTION	PART No.	QTY.	EXPECTED % of VEHICLES REQUIRING PARTS*
Battery	Interstate Battery MT5-49/H8	1	100
Snubber	LR056022	8	100
Battery Pad	LR055670	1	100
Cable Clip	LR055390	1	100



**NOTE: \* when ordering parts, order only the expected percentage demand of parts identified**

**SPECIAL TOOLS:**

**NOTE: This document is an 'Active Bulletin' that will display a functional programming shortcut if accessed within a diagnostic session using SDD.**

SDD with latest SDD-DVD and Calibration File; first available on DVD135.01 v.145

Jaguar Land Rover-approved Midtronics Battery Power Supply



Refer to Workshop Manual / Service Instruction for any required tools

**WARRANTY:**

**NOTE: Check DDW to ensure that the vehicle is affected by this program prior to undertaking any rework action. Repair procedures are under constant review, and therefore times / prices are subject to change; those quoted here must be taken as guidance only. Refer to the Repair Times Searcher (RTS) on TOPIx to obtain the latest repair time. At the time of confirming a booking for vehicle repair, ensure that all outstanding Service Actions are identified to ensure the correct parts are available and adequate workshop time is allocated for repairs to be completed at one visit.**

Warranty claims must be submitted quoting Program Code 'Q322' together with the relevant Option Code from the table. The SRO and part information listed have been included for information only. The Option Code(s) that allows for the drive in / drive out allowance can only be claimed if the vehicle is brought into the workshop for this action alone to be undertaken.

This program is valid for a limited time only. Warranty claims with a repair date prior to the **31 December 2015** closure date must be submitted for payment within 30 calendar days of completion of the repair.

PROGRAM CODE	OPTION CODE	DESCRIPTION	SRO	TIME (HOURS)	PARTS	QTY. / VALUE
Q332	B	 <b>NOTE: RANGE ROVER SPORT (L494)</b>  Remove and replace battery; tighten battery ground connection; and run battery replacement Fit snubbers, battery pad, and clip	86.15.01.02 05.10.50	0.50 0.50	ZZZ999 LR056022 LR055670 LR055390	\$219.13 (CAN); \$211.64 (USA) 8 1 1
Q332	C	 <b>NOTE: RANGE ROVER SPORT (L494)</b>  Remove and replace battery; tighten battery ground connection; and run battery replacement Fit snubbers, battery pad, and clip Drive in/drive out	86.15.01.02 05.10.50 02.02.02	0.50 0.50 0.20	ZZZ999 LR056022 LR055670 LR055390	\$219.13 (CAN); \$211.64 (USA) 8 1 1
Q332	B	 <b>NOTE: RANGE ROVER (L405)</b>	86.15.01.02 05.10.50	0.40 0.50	ZZZ999 LR056022 LR055670 LR055390	\$219.13 (CAN); \$211.64 (USA) 8

		Remove and replace battery; tighten battery ground connection; and run battery replacement Fit snubbers, battery pad, and clip				1 1
Q332	C	 <b>NOTE: RANGE ROVER (L405)</b>  Remove and replace battery; tighten battery ground connection; and run battery replacement Fit snubbers, battery pad, and clip Drive in/drive out	86.15.01.02 05.10.50 02.02.02	0.40 0.50 0.2	ZZZ999 LR056022 LR055670 LR055390	\$219.13 (CAN); \$211.64 (USA) 8 1 1

 **NOTE: Normal Warranty policies and procedures apply**

### **SERVICE INSTRUCTION:**

1. Remove the battery (see TOPIx Workshop Manual, section 414-01).
2. Tighten the battery cable ground connection to 9 Nm.

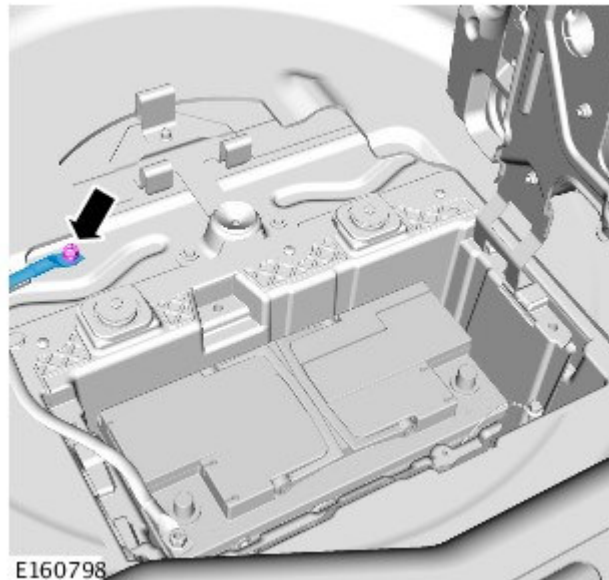

3.  **CAUTION: Make sure that the surface is clean and free of foreign material.**

Remove the inner battery tray.

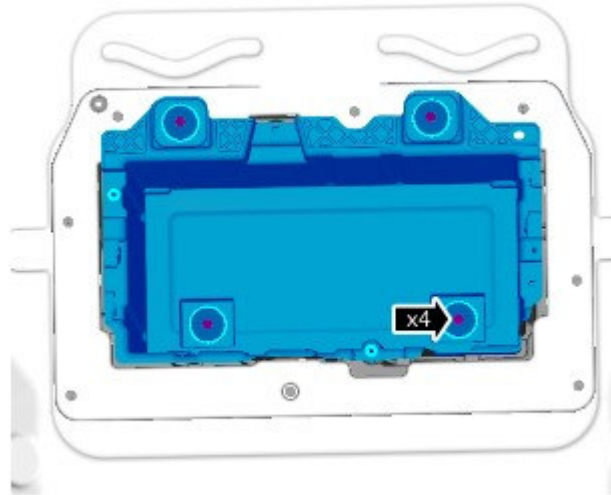

E159911

**4. Fit 8 x Rubber Snubber Pads (120 x 45 x 6mm) as shown:**

- Pad 80-90mm from top surface.

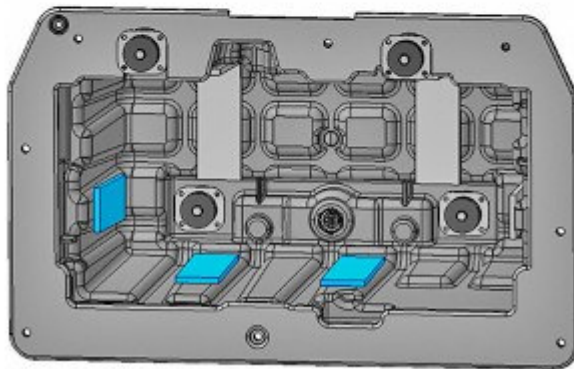
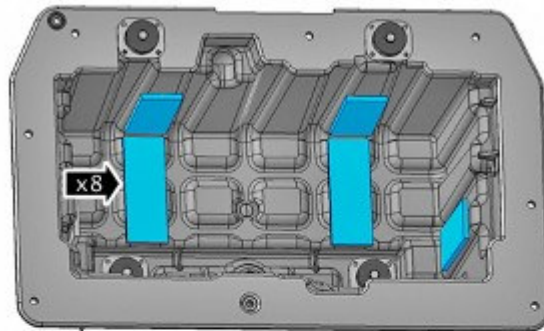

E159912

5. Drill 6mm hole for cable fir-tree fixing as shown.

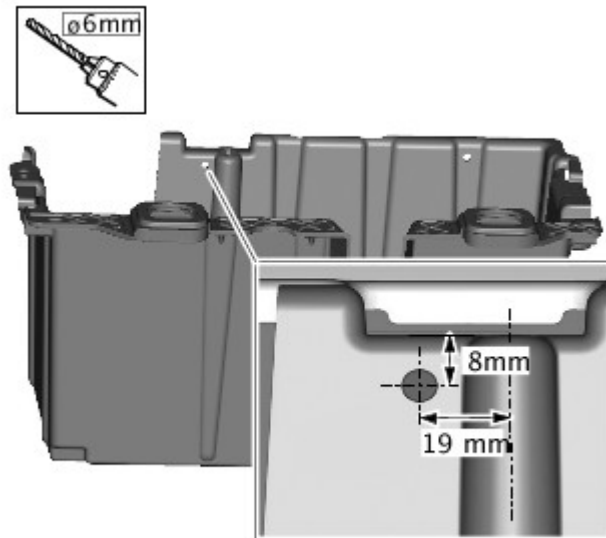

E159913

6. Install the inner tray.

- Locate the bolts in the lower part of the battery box first to aid fitment.
- Torque the four (4) fixings to 7Nm.

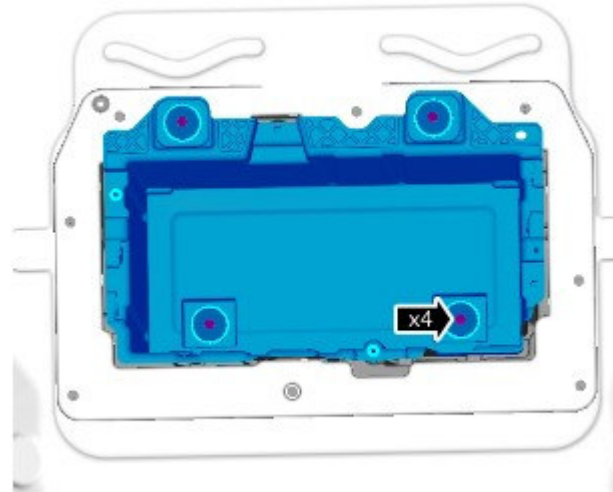

E159911

7.  **NOTE: If required, use soapy water on the pad to aid fitment.**

Fit battery pad.

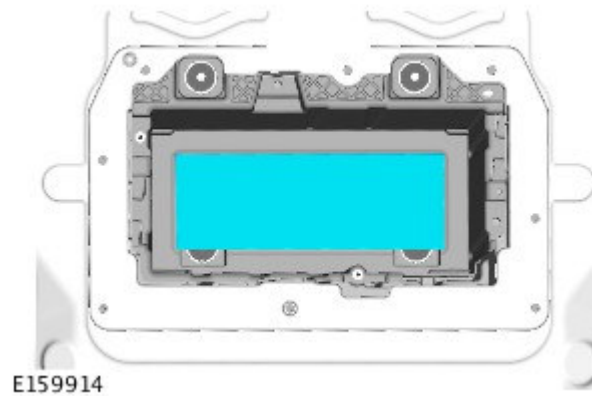

8. Position of clip (80mm from end of terminal).

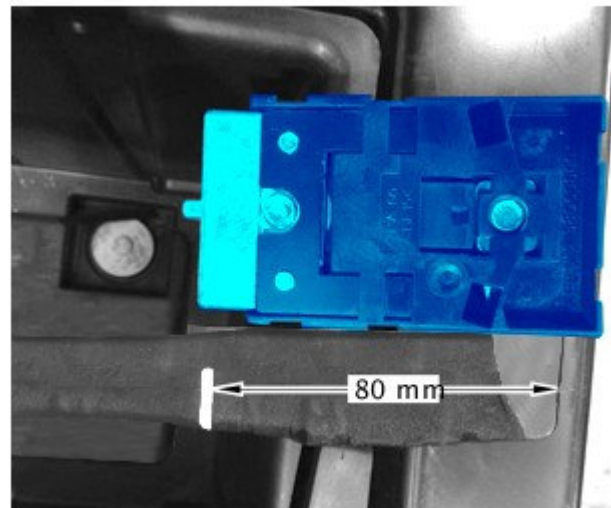

9. Install new clip and push fully in to the drilled hole; trim off excess cable.

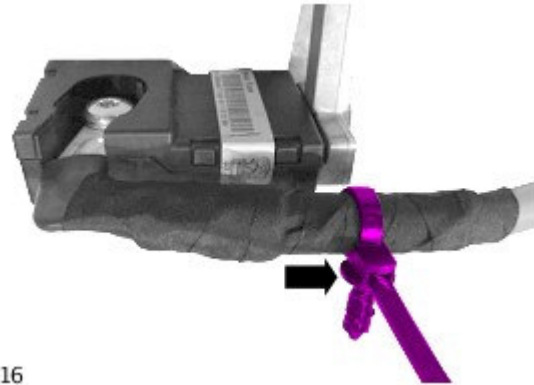

E159916

10.  **CAUTION: Make sure the cable is positioned parallel to the longest side of the battery and battery box.**

-  **CAUTION: Make sure the harness lies below the level of the carpet.**

Install the battery positive cable as shown.

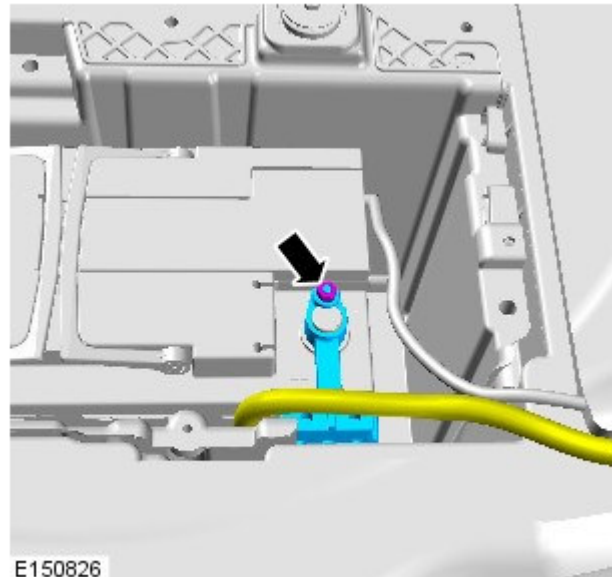

E150826

11.  **CAUTION: The correct Foam EPP pad must be present; without the correct pad, battery is not restrained and will lead to premature failure.**

Check the correct foam pad is fitted.

- If the correct pad is fitted, continue to the next step.
- If the correct pad is not fitted, install the correct pad.

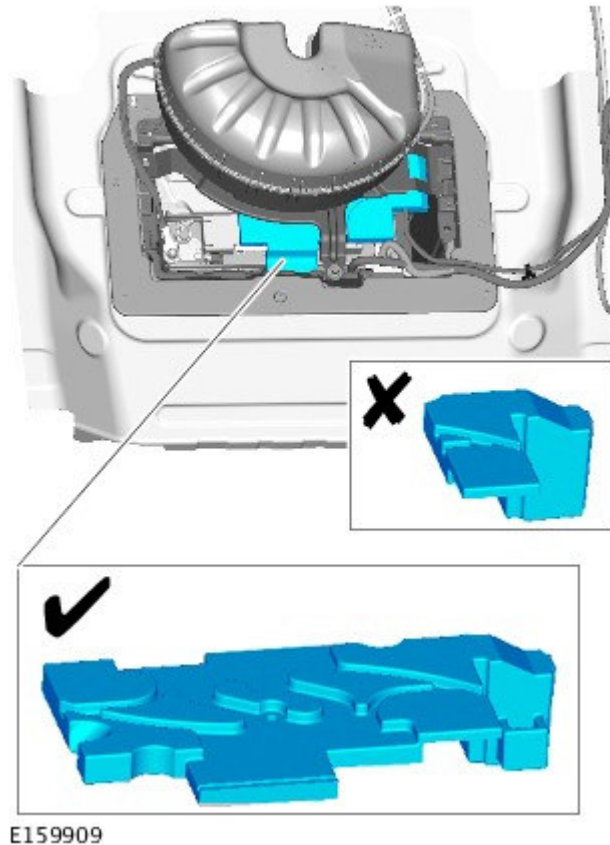

12.  **CAUTION: Make sure to follow all Cautions in Workshop Manual.**

Install the battery (see TOPIx Workshop Manual, section 414-01).

13.  **CAUTION: Ensure all ignition 'ON' / ignition 'OFF' requests are carried out; failure to perform these steps may cause damage to control modules in the vehicle.**

 **CAUTION: A Jaguar Land Rover-approved Midtronics battery power supply must be connected to the vehicle battery during SDD diagnosis / module programming.**

 **NOTE: SDD must be loaded with DVD135.01 v.145 or later.**

Connect the Jaguar Land Rover-approved Midtronics battery power supply to the vehicle battery.

14. Turn ignition 'ON' (engine not running).

15. Connect the Symptom Driven Diagnostics (SDD) system to the vehicle and begin a new session.



**16.** Follow the on-screen prompts, allowing SDD to read the VIN and identify the vehicle and initiating the data collect sequence.

**17.** Select 'Service Functions' from the Session Type screen and then select the following:

- Battery - Battery replacement

**18.** Follow all on-screen instructions to complete this task.

**19.** Exit the current session.

**20.** Disconnect the SDD and the battery power supply from the vehicle.