

S-SB-0010-13

February 28, 2013

Brief Engine Knock/Rattle Noise at Cold Startup

Service Category Engine/Hybrid System

Section Engine Mechanical

Market USA

Scion Supports ASE Certification 

Applicability

YEAR(S)	MODEL(S)	ADDITIONAL INFORMATION
2011 – 2012	tC	VDS(s): JF5C7 WMI(s): JTK

Introduction

Immediately following a cold soak startup, some 2011 – 2012 model year vehicles equipped with the 2AR-FE engine may exhibit a brief knock/rattle noise from the engine compartment for approximately one second. Follow the repair procedure below to address this condition.

Production Change Information

This bulletin applies to vehicles produced **BEFORE** the Production Change Effective VIN shown below.

MODEL	DRIVETRAIN	PLANT	PRODUCTION CHANGE EFFECTIVE VIN
tC	2WD	Tsutsumi	JTKJF5C7#C3032648

Warranty Information

OP CODE	DESCRIPTION	TIME	OFF	T1	T2
140021	R & R Camshaft Timing Gear Assembly	2.5	13050-36011 13050-36030 13050-0V011	06	40

APPLICABLE WARRANTY

- This repair is covered under the Toyota Powertrain Warranty. This warranty is in effect for 60 months or 60,000 miles, whichever occurs first, from the vehicle's in-service date.
- Warranty application is limited to occurrence of the specified condition described in this bulletin.

Brief Engine Knock/Rattle Noise at Cold Startup

Parts Information

PREVIOUS PART NUMBER	CURRENT PART NUMBER	PART NAME	QTY
13050-36011 13050-36030 13050-0V011	13050-0V040	Gear Assembly, Camshaft Timing	1
11213-36020	Same	Gasket, Cylinder Head Cover	1
11159-36011	11159-0V011	Gasket, Camshaft Bearing Cap Oil Hole No. 1	2
90430-10024	90430-A0001	Gasket, Camshaft Bearing Cap Oil Hole No. 2	1
11328-36020	11328-0V010	Gasket, Timing Chain Tensioner	1
11329-36010	Same	Gasket, Timing Chain Cover, No. 2	1
13552-36010	13552-0V010	Gasket (for Chain Tensioner)	1

Required Tools & Equipment

SPECIAL SERVICE TOOLS (SST)	PART NUMBER	QTY
Torque Wrench Adapter*	<u>09249-63010-01</u>	1

REQUIRED MATERIALS	QTY
FIPG Sealant: Three Bond 1207B, or Equivalent	As Needed

REQUIRED EQUIPMENT	SUPPLIER	PART NUMBER	QTY
Techstream 2.0*	ADE	TS2UNIT	1
TIS Techstream		TSPKG1	
Techstream Lite		TSLITEDLR01	

NOTE

- Only **ONE** of the Techstream units listed above is required.
- Software version 8.00.034 or later is required.
- Additional SSTs may be ordered by calling 1-800-933-8335.
- Additional Techstream units may be ordered by calling Approved Dealer Equipment (ADE) at 1-800-368-6787.

* Essential SST.

Brief Engine Knock/Rattle Noise at Cold Startup

Repair Procedure

1. Confirm the brief knock/rattle noise condition. See attached video for an example of the engine knock/rattle noise:
[Engine Knock/Rattle Noise Example](#)

2. Remove the cylinder head cover.
 - A. Relocate the engine harness that lies across the top of the cylinder head cover.
 - B. Remove the ignition coils.
 - C. Remove the 16 bolts and cylinder head cover.

Figure 1.

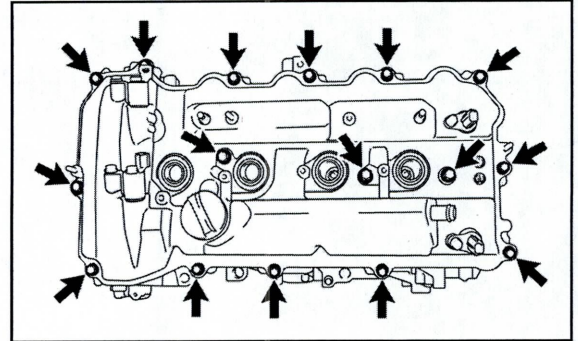

3. Remove the chain tensioner.
 - A. Remove the right front wheel.
 - B. Remove the front fender apron seal RH.
 - C. Remove the V-ribbed belt for the vane pump.
 - D. Rotate the crankshaft clockwise and set the No. 1 cylinder at $+10^\circ$ from the TDC/compression.
 - E. After the timing marks are aligned on the VVT gear, place paint marks on the chain and both gears.

Figure 2.

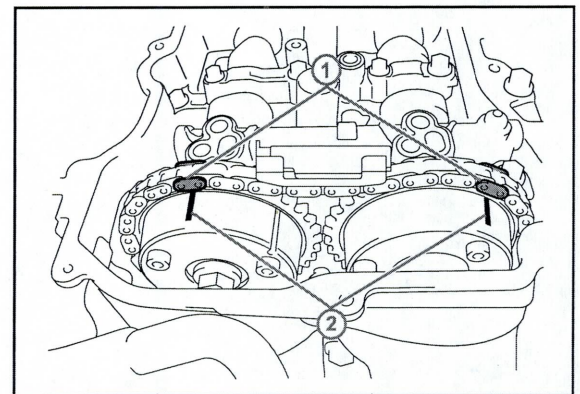

1	Paint Marks
2	Timing Marks

Brief Engine Knock/Rattle Noise at Cold Startup

Repair Procedure (Continued)

- F. Rotate the crankshaft counterclockwise by 10° and loosen the tension of the chain.
- G. Remove the timing chain cover plate.
- H. Align the holes of the stopper plate and tensioner, and insert a pin into the stopper plate hole to lock the tensioner.

Figure 3.

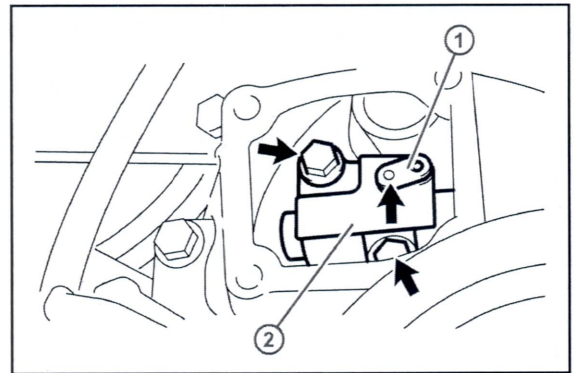

1	Stopper Plate
2	Timing Tensioner

- I. Remove the 2 bolts and chain tensioner.
- 4. Remove the timing chain guide by removing the bolt.

Figure 4.

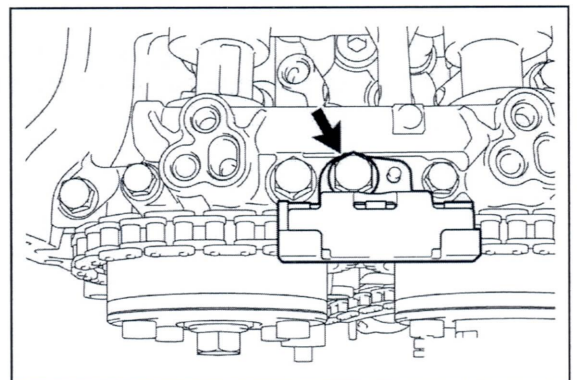

Brief Engine Knock/Rattle Noise at Cold Startup

Repair Procedure (Continued)

5. Remove the intake side VVT gear.

A. Remove the service hole plug.

Figure 5.

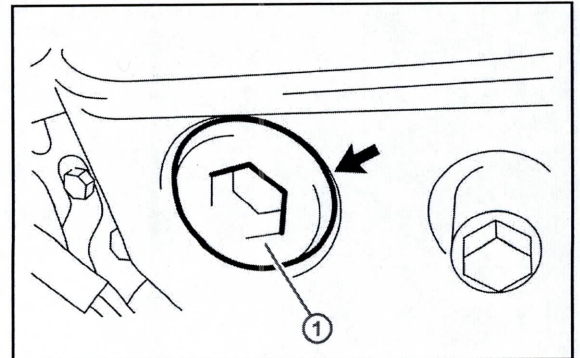

1	Service Hole Plug
---	-------------------

B. Insert the tool through the service hole and remove the bolt of the intake VVT gear while holding the camshaft stationary with a wrench.

Figure 6.

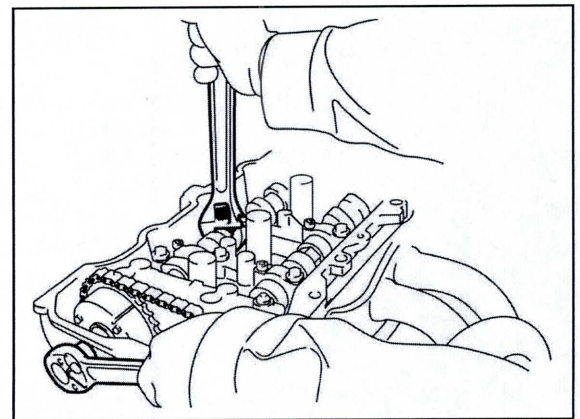

NOTICE

- Be careful **NOT** to damage the cylinder head or spark plug tube with the wrench.
- Do **NOT** disassemble the camshaft timing gear.

Brief Engine Knock/Rattle Noise at Cold Startup

Repair Procedure (Continued)

- C. After the VVT gear is slid in the arrow direction as shown in Figure 7, lower the VVT gear and remove the chain from the VVT gear.

Figure 7.

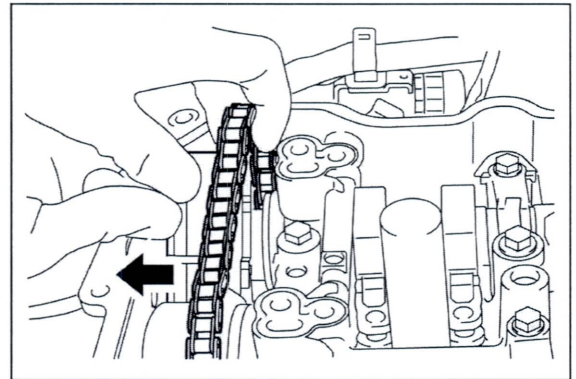

- D. Remove the VVT gear from the cam housing.
- E. Tie the timing chain to ensure it stays properly aligned with the exhaust and crankshaft timing gear pulleys.

NOTICE

The VVT gear bolts may interfere with the housing during removal. After the VVT gear slides out from the camshaft, carefully rotate the VVT gear to the position shown in Figure 8 to avoid interference and remove it in the arrow direction shown.

Figure 8.

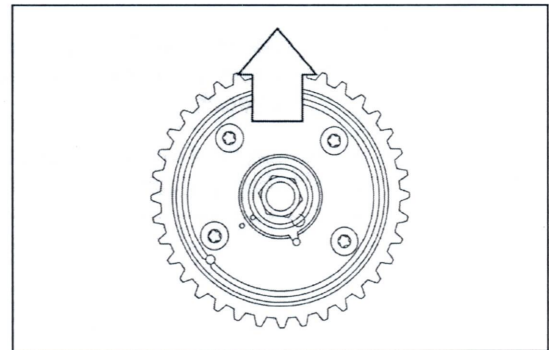

Brief Engine Knock/Rattle Noise at Cold Startup

Repair Procedure (Continued)

6. Install the intake side VVT gear.
 - A. Transfer the paint marks from the old gear to the new gear.
 - B. Confirm the new gear is in the unlocked position prior to installation.

NOTICE

The camshaft timing gear **MUST** be in the unlocked position when installing on the camshaft to prevent damage to the lock pin during tightening. Please see step E for instructions to unlock the camshaft timing gear.

Figure 9.

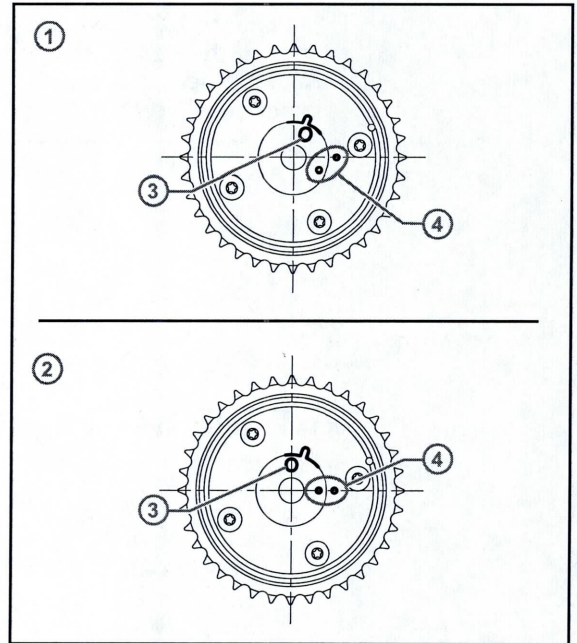

1	Advanced (Unlocked) Position
2	Retarded (Locked) Position
3	Knock Pin Hole
4	Alignment Mark

- C. Remove the tie from the timing chain.

Brief Engine Knock/Rattle Noise at Cold Startup

Repair Procedure (Continued)

- D. Insert the tool from the service hole and install the bolt of the intake VVT gear.

Figure 10.

NOTICE

Make sure NOT to lock the camshaft timing gear. If the camshaft timing gear is locked, release the lock according to the following procedure (step E).

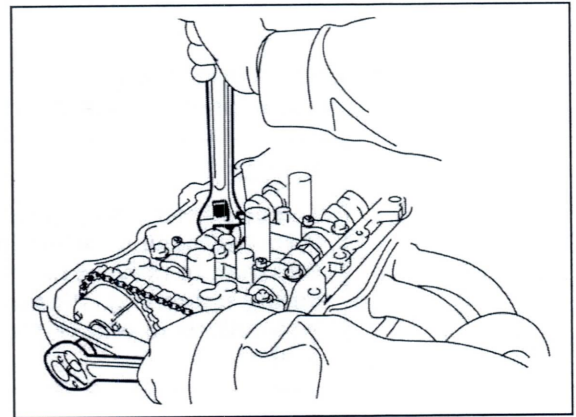

- E. Inspect the camshaft timing gear lock.

If the camshaft timing gear is locked, release the lock according to the following procedure.

- (1) After cleaning and degreasing the intake side VVT oil hole on the No. 1 camshaft bearing cap, completely seal the oil hole with adhesive tape or equivalent as shown in Figure 11 to prevent air from leaking.

Figure 11.

NOTICE

Be sure to seal the oil hole completely because air leaks due to insufficient sealing will prevent the lock pin from being released.

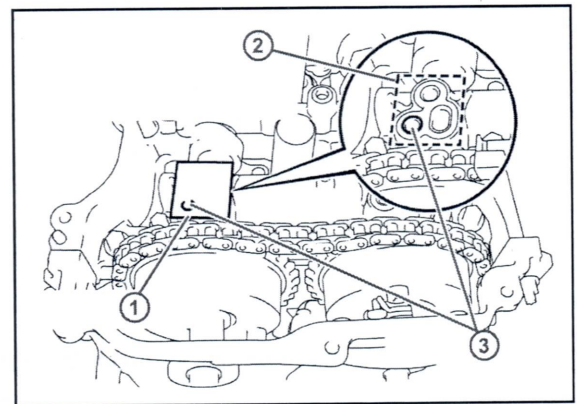

1	Adhesive Tape
2	Adhesive Tape Sealing Area
3	Make a Hole in Adhesive Tape

- (2) Make a hole in the adhesive tape covering the oil hole as shown in Figure 11.

Brief Engine Knock/Rattle Noise at Cold Startup

Repair Procedure (Continued)

- (3) Apply approximately 200 kPa (2.0 kgf/cm², 29 psi) of air pressure to the hole made in the preceding step, then forcibly turn the camshaft timing gear assembly in the advance direction (counterclockwise).

CAUTION

Cover the oil passages with a piece of cloth when applying pressure to keep oil from splashing.

NOTICE

- If air leaks out, reattach the adhesive tape.
- Do NOT allow the camshaft timing gear assembly to lock. If it locks, release the lock pin again.

HINT

- The camshaft timing gear assembly may be turned in the advance direction without applying any force.
- If enough air pressure cannot be applied because of air leakage from the port, releasing the lock pin may be difficult.

Figure 12.

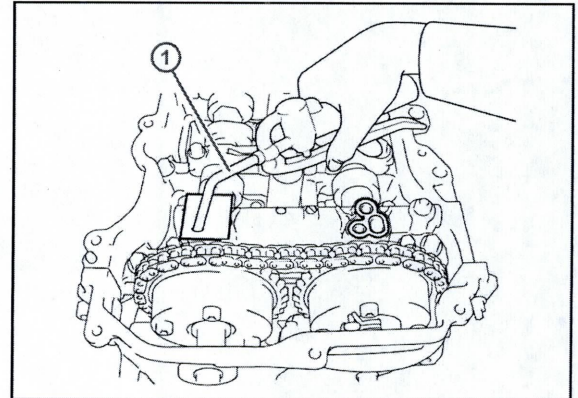

1	Compressed Air
---	----------------

- (4) Remove the adhesive tape on the VVT hole.
- F. Tighten the bolt of the intake VVT gear.
Torque: 85 N*m (867 kgf*cm, 63 ft*lbf)
- G. Lock the gear by rotating the camshaft timing gear assembly clockwise.

Brief Engine Knock/Rattle Noise at Cold Startup

Repair Procedure (Continued)

7. Install the service hole plug with a new gasket.
Torque: 30 N*m (306 kgf*cm, 22 ft*lbf)

Figure 13.

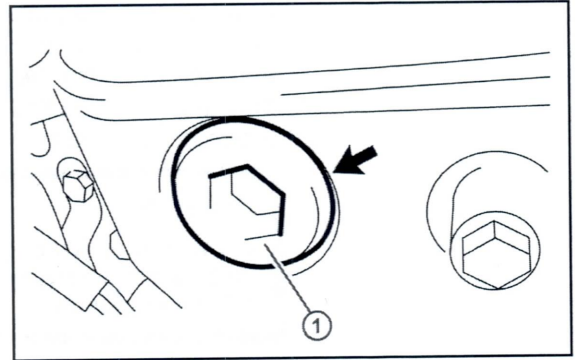

1	Service Hole Plug
---	-------------------

8. Install the chain to the VVT gear.

NOTICE
Align the marks that were placed on the gears and chain.

Figure 14.

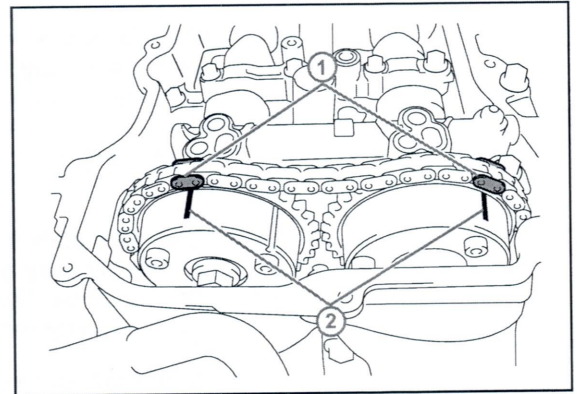

1	Paint Marks
2	Timing Marks

Brief Engine Knock/Rattle Noise at Cold Startup

Repair Procedure (Continued)

9. Install the timing chain guide with the bolt.

Torque: 21 N*m (214 kgf*cm, 15 ft*lbf)

Figure 15.

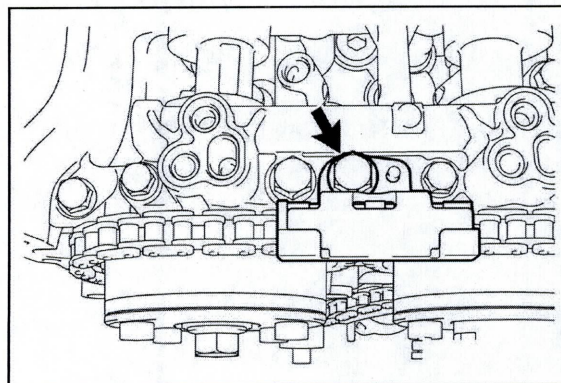

10. Install the chain tensioner.

- A. Install a new gasket and the chain tensioner to the service hole.

Torque: 10 N*m (102 kgf*cm, 7 ft*lbf)

- B. When installing the tensioner, pull out the pin and release the tensioner.

- C. Install the timing chain cover plate.

Install a new gasket and the timing chain cover plate with the 4 bolts.

Torque: 10 N*m (102 kgf*cm, 7 ft*lbf)

Figure 16.

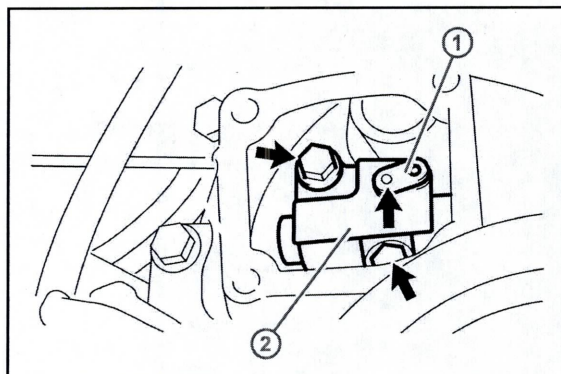

1	Stopper Plate
2	Timing Tensioner

Brief Engine Knock/Rattle Noise at Cold Startup

Repair Procedure (Continued)

11. Install the cylinder head cover sub-assembly.
 - A. Apply a light coat of engine oil to 3 new gaskets.
 - B. Install the 3 gaskets to the camshaft bearing caps.

Figure 17.

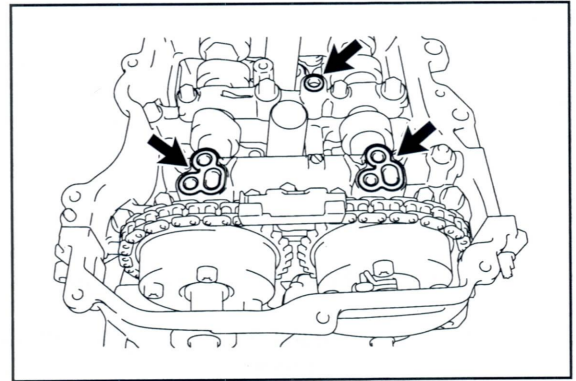

- C. Install a new gasket to the cylinder head cover.

NOTICE

Remove any oil from the contact surface.

Brief Engine Knock/Rattle Noise at Cold Startup

Repair Procedure (Continued)

D. Apply FIPG sealant as shown in Figure 18.

FIPG Sealant: Three Bond 1207B, or equivalent

Standard Seal Diameter: 3.0 to 6.0 mm (0.118 to 0.236 in.)

Application Width A: 5.0 mm (0.197 in.)

NOTICE

- Remove any oil from the contact surface.
- Install the cylinder head cover within 3 minutes and tighten the bolts within 15 minutes after applying FIPG sealant.

Figure 18.

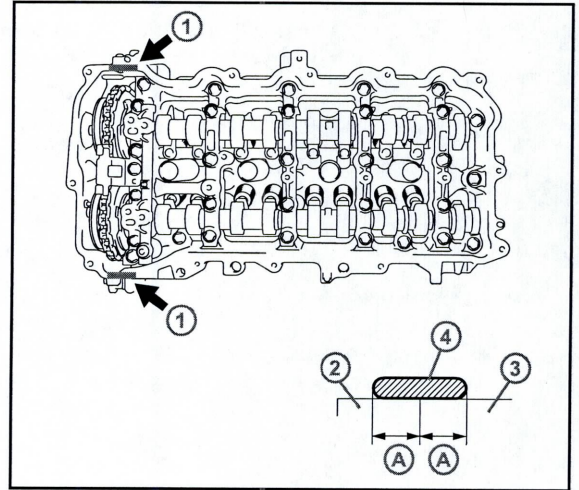

1	FIPG Sealant
2	Timing Chain Cover
3	Camshaft Housing
4	3.0 to 6.0 mm
A	Application Width "A"

Brief Engine Knock/Rattle Noise at Cold Startup

Repair Procedure (Continued)

- E. Align the cylinder head cover with pin A.
Then align the cylinder head cover with pin B
and install the cylinder head cover.

Figure 19.

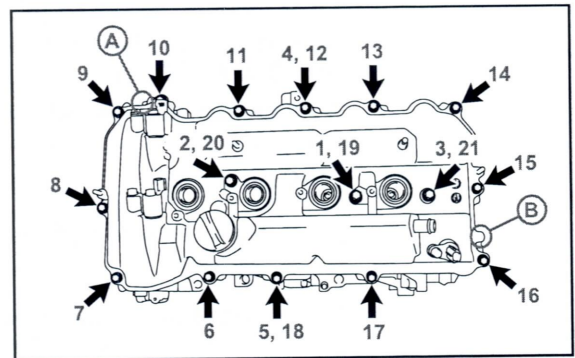

A	Pin A
B	Pin B

- F. Install the 16 bolts and then tighten the bolts in the order shown in Figure 19.

Torque: 12 N*m (122 kg*cm, 9 ft*lbf)

NOTICE

Do NOT apply oil for at least 4 hours after the installation.

12. Confirm the repair.