

Retailer Service Action

2013 Infiniti JX35 and 2014 Infiniti QX60 Front Brake Torque Member

Attention: **Retailer Principals, Sales, Parts, and Service Managers**

******* Retailer Service Action Announcement *******

Infiniti is conducting a Retailer service action to inspect and, if necessary, replace one or both of the front brake torque members on certain specific 2013 Infiniti JX35 or 2014 Infiniti QX60 vehicles currently in Retailer inventory only.

******* Vehicle Identification – Retailer Inventory *******

2013 Infiniti JX35 or 2014 Infiniti QX60 vehicles **subject to this Retailer service action can be identified through two methods:**

- SERVICE COMM – **Beginning October 19, 2013**, Retailer service departments can **complete an inquiry on SERVICE COMM – I.D. PC251 - to determine an affected vehicle.**
- VIN List – **As a courtesy, posted with this announcement is a list of affected Retailer inventory VINs by region, district, and Retailer Code. This VIN list is available on NNA.net under My Documents Sales>Campaigns>, Parts>Campaigns>, Service>Campaigns> categories.**

******* Retailer Responsibility *******

It is the Retailer's responsibility to check SERVICE COMM – **I.D. PC251** – for the status on each vehicle falling within the range of this Retailer service action, which is currently in its inventory.

Infiniti requires retailers to perform this procedure only on vehicles in inventory specifically identified in SERVICE COMM before they are retailed.

Infiniti Aftersales
10/18/13

Repair Overview

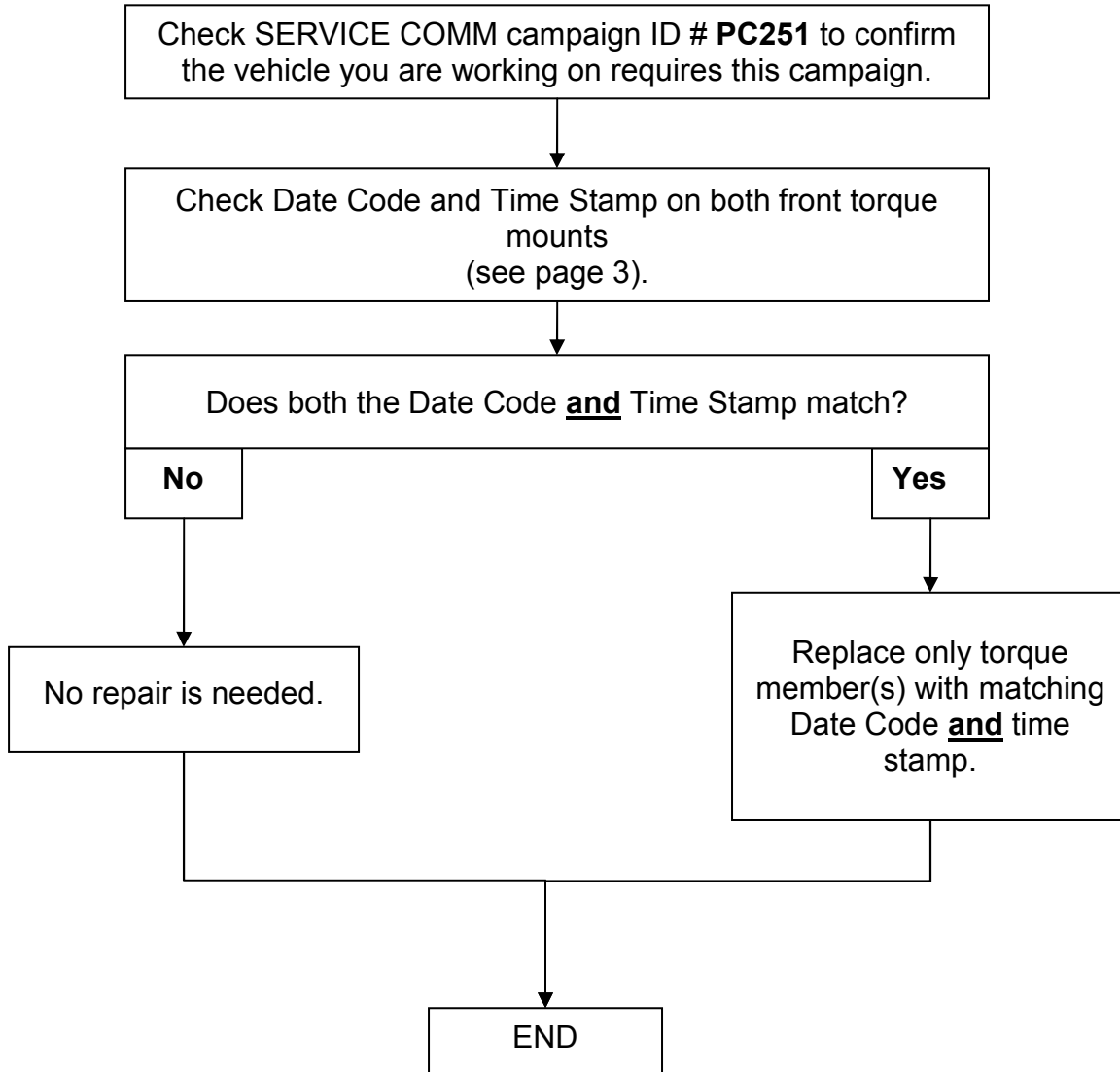

SERVICE PROCEDURE

Check Date Codes

1. Raise the vehicle so you can access the back side of the front brake calipers.
2. On the back side of the front brake torque members (both sides) locate the "Date Code" and "Time Stamp". (see figure 1 below as an example of where to find these items).

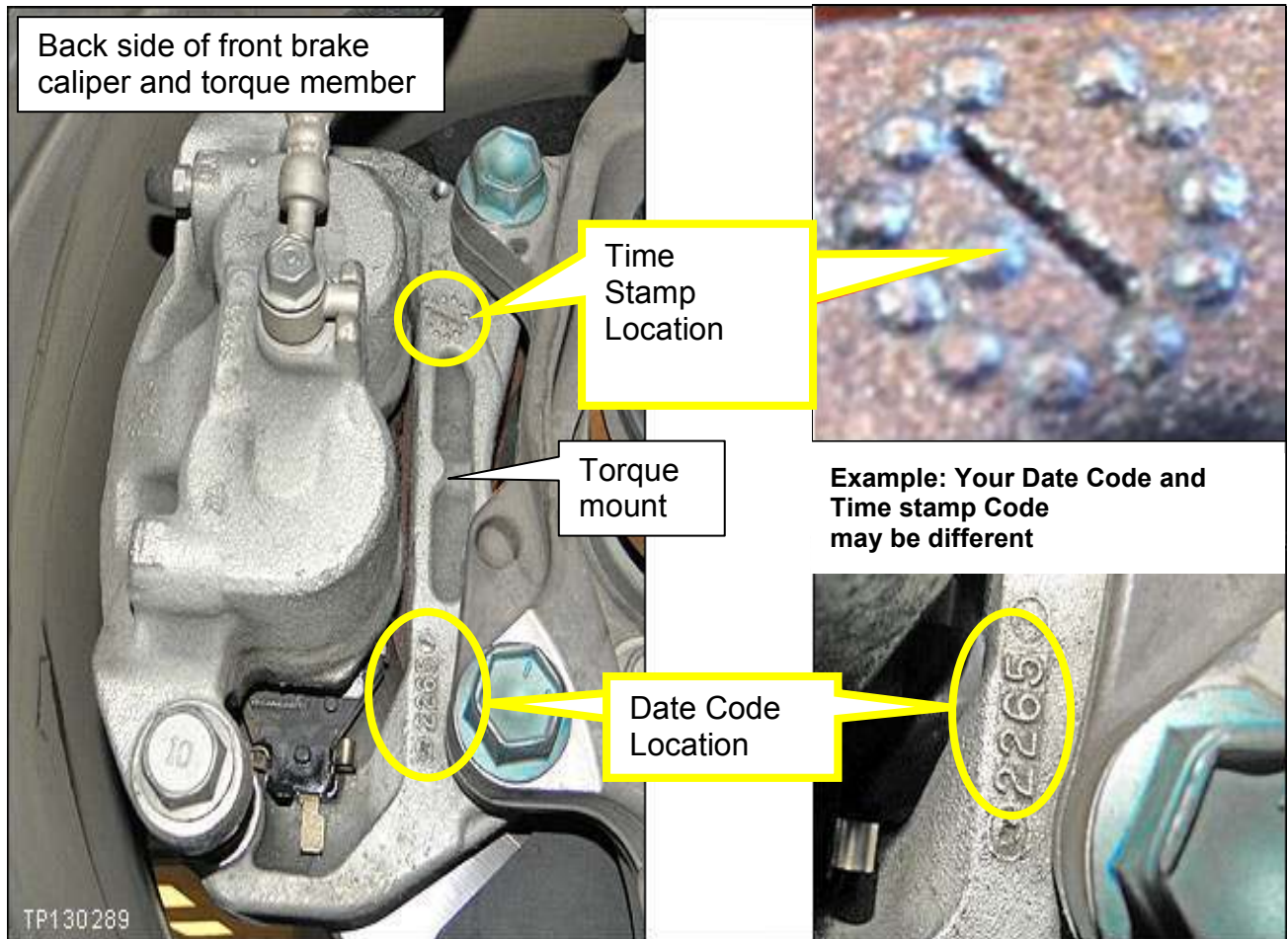

Figure 1

NOTE:

- The above photo is of the passenger side. The driver side will have the Date Code at the top of the torque member and the Time Stamp will be at the bottom of torque member.
- In the example above the Date Code is 2265. Your Date Code may be different.

3. Write the Date Codes here, and on the repair order:

Passenger side _____ Driver side _____

- If date code on either side is 3280, go to the time stamp inspection.
- If date code 3280 is not on either side, no further action is needed.

Replace Torque Member(s)

NOTE:

- Only replace torque member if the Date Code and Time Stamp matches as indicated on the previous page.
- Some vehicles may need only one torque member replaced, some may need both replaced.

1. Remove the front wheel.
2. Remove the torque member as follows:
 - Refer to Figure 2 as needed.
 - a. Remove the brake caliper bolts.
 - These bolts will not be reused.
 - Do not loosen or remove any hydraulic lines.
 - b. Remove the brake caliper; slide it off of the brake pads and secure it out of the way.

CAUTION: Do not allow the weight of the brake caliper to hang by the hydraulic hose.

- c. Remove the torque member bolts and then remove the torque member.

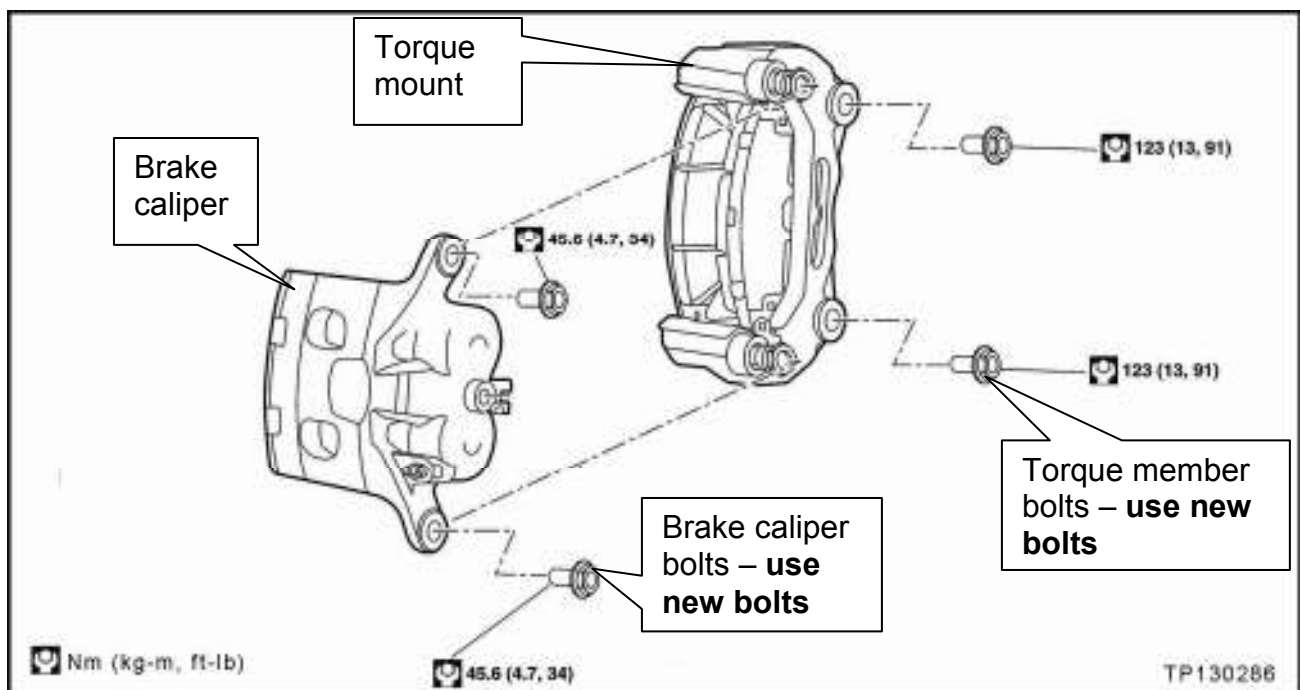

Figure 2

3. Install the new torque member with new torque member bolts.

NOTE: The new torque mount comes with sliding pins, sliding pin boots, and pad retainers.

- Make sure to install the correct torque mount on the correct side (refer to Figure 3 and the Parts Information).
- Torque bolts to:
123 N•m (13 kg-m, **91 ft-lb**).

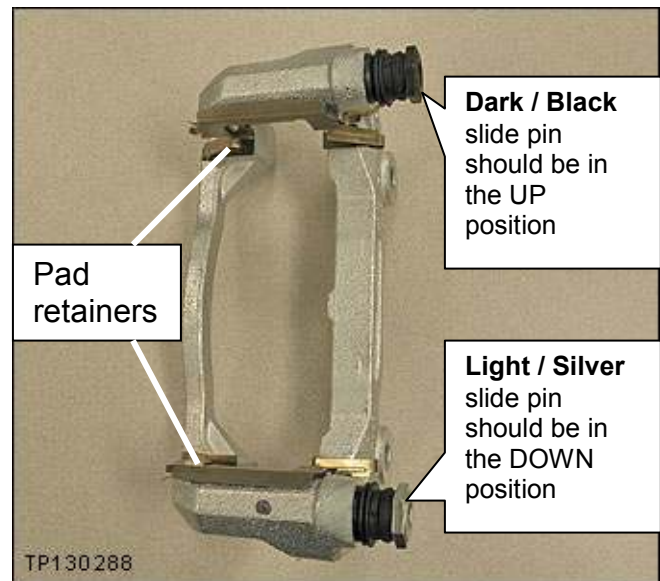

Figure 3

4. Swap the brake pads from the old torque member to the new torque member.

- Make sure the brake pad wear indicator and end spring are in the UP position / top of the caliper
- Refer to Figure 4 as needed.

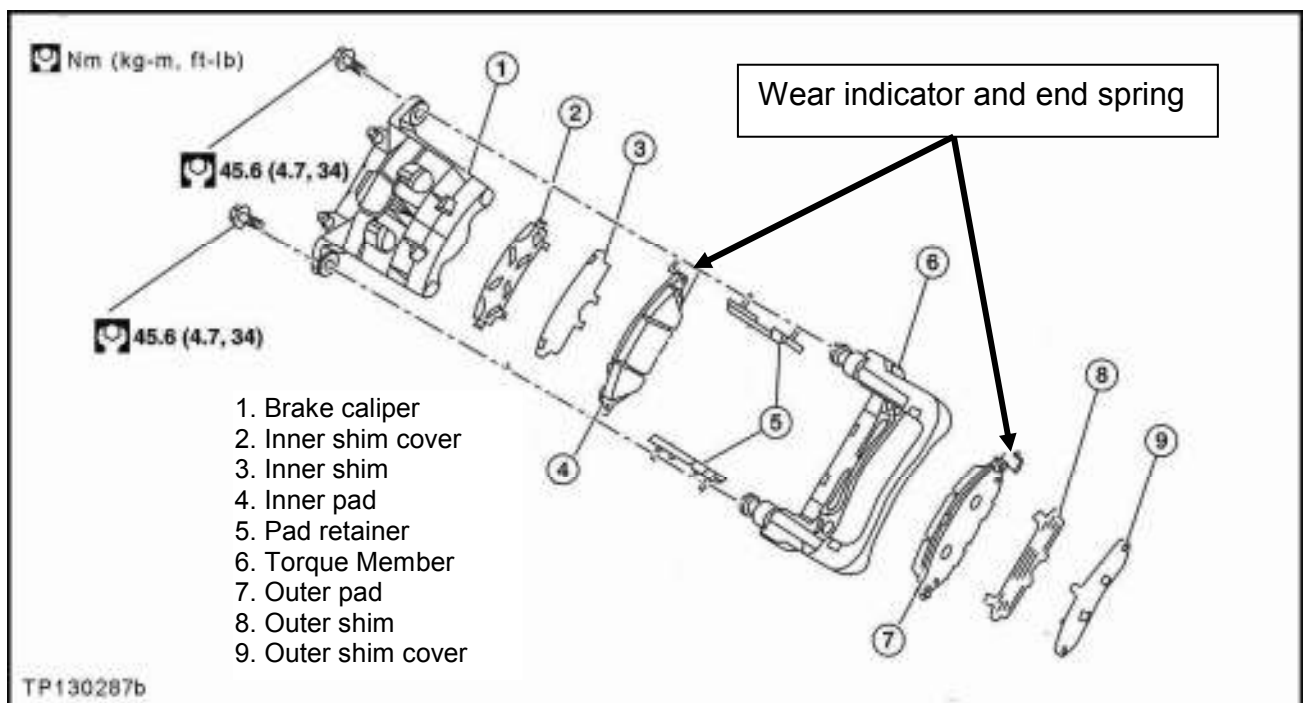

Figure 4

5. Slide the brake caliper over the brake pads.
6. Install the brake caliper bolts (see Figure 5).
 - **Use new bolts.**
 - Torque bolts to 45.6 N•m (4.7 kg-m, **34 ft-lb**).

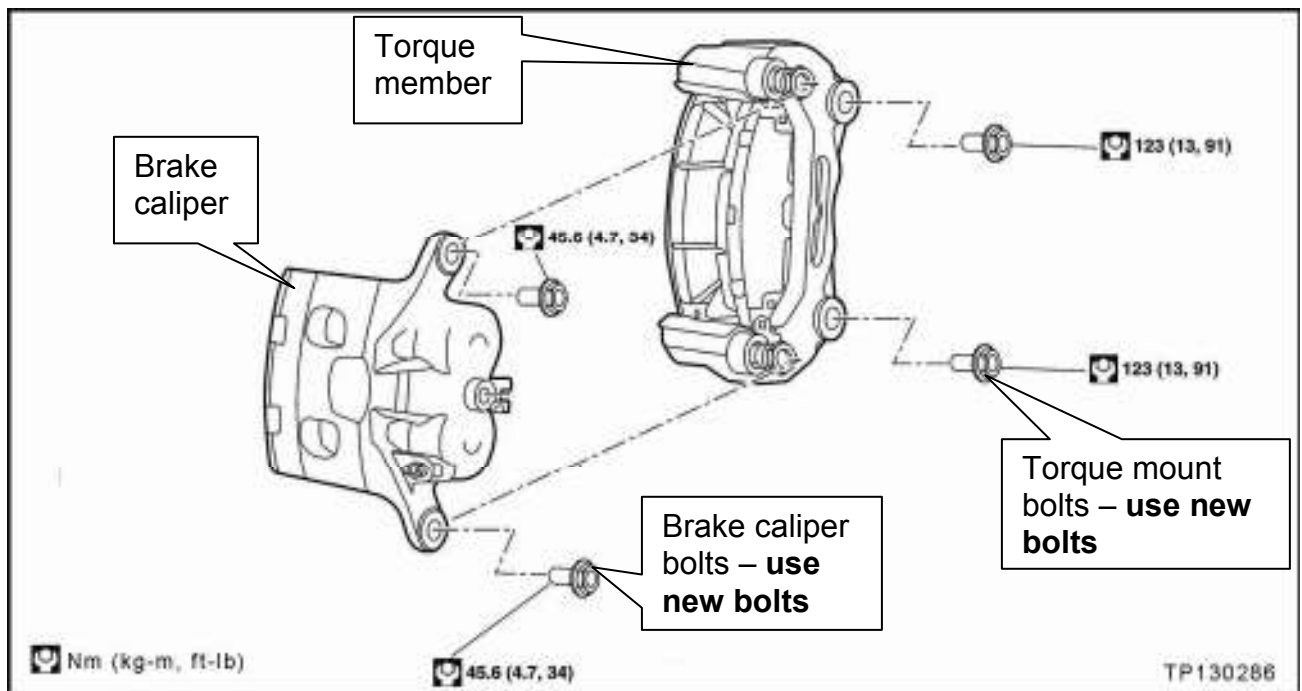

Figure 5

7. Reinstall the front wheel(s).
 - Torque lug nuts to 113 N•m (12 kg-m, **83 ft-lb**).
8. Before driving the vehicle, press the brake pedal a few times.
9. Render the old torque member(s) unusable by damaging the threads in the mounting bolt holes.

PARTS INFORMATION

DESCRIPTION	PART #	QUANTITY
Torque Member-LH (Left / Driver side – includes 2 caliper bolts, sliding pins, sliding pin boots, and pad retainers)	410A5 – 3JA0A	1; if needed
Torque Member-RH (Right / Passenger side – includes 2 caliper bolts, sliding pins, sliding pin boots, and pad retainers)	410A4 – 3JA0A	1; if needed
Torque Member Bolts	41005 – 1MD0A	2 per side; if needed

CLAIMS INFORMATION

Submit a “CM” line claim using the following claims coding:

CAMPAIGN (“CM”) I.D.	DESCRIPTION	OP CODE	FRT
PC251	Inspect both torque members	PC2510	0.2 hrs.

OR

CAMPAIGN (“CM”) I.D.	DESCRIPTION	OP CODE	FRT
PC251	Inspect both torque members and replace one (1) - one side	PC2511	0.7 hrs.

OR

CAMPAIGN (“CM”) I.D.	DESCRIPTION	OP CODE	FRT
PC251	Inspect both torque members and replace both	PC2512	0.9 hrs.