



SERVICE CAMPAIGN BULLETIN

Reference:

NTB12-011c

Date:

March 7, 2013

VOLUNTARY SERVICE CAMPAIGN 2007-2012 ALTIMA SEDAN & COUPE BRAKE MASTER CYLINDER

This bulletin has been amended. "This Voluntary Service Campaign **DOES NOT APPLY** to Altima Hybrid (L32H) vehicles" was added to the Applied Vehicles section. Please discard previous versions.

CAMPAIGN ID #: PC125

APPLIED VEHICLES: 2007 – 2012 Altima Sedan & Coupe (L32 & CL32)

» This Voluntary Service Campaign **DOES NOT APPLY** to Altima Hybrid (L32H) vehicles «

Refer to the flow chart (Repair Overview) on the next page for campaign eligibility.

INTRODUCTION

Nissan is conducting a Voluntary Service Campaign on Model Year 2007-2012 Nissan Altima (L32) Sedan and Coupe vehicles to inspect the brake system in vehicles with an illuminated brake warning lamp. Nissan dealers will inspect the brake system and confirm that no brake fluid leak is present. If no leak is present, the reservoir will be topped off. If a leak in the brake master cylinder is identified, the brake master cylinder will be replaced.

The affected vehicles are equipped with a brake warning lamp that will illuminate to alert the driver when fluid in the brake fluid reservoir is low. Fluid in the reservoir may become low due to normal brake pad wear and not because of any brake system malfunction. While in most instances an illuminated brake warning lamp is due to normal brake pad wear, a small percentage of vehicles affected by this campaign may have a slow brake fluid leak at the brake master cylinder.

IDENTIFICATION NUMBER

Nissan has assigned identification number PC125 to this campaign. This number must appear on all communications and documentation of any nature dealing with this campaign.

DEALER RESPONSIBILITY

This action is only required if the brake warning lamp is currently illuminated, or the customer states it was recently illuminated while driving. In addition, this campaign is intended to promote customer satisfaction. This inspection may also be performed based on customer request, regardless of the warning lamp illumination.

Nissan Bulletins are intended for use by qualified technicians, not 'do-it-yourselfers'. Qualified technicians are properly trained individuals who have the equipment, tools, safety instruction, and know-how to do a job properly and safely. NOTE: If you believe that a described condition may apply to a particular vehicle, DO NOT assume that it does. See your Nissan dealer to determine if this applies to your vehicle.

Repair Overview

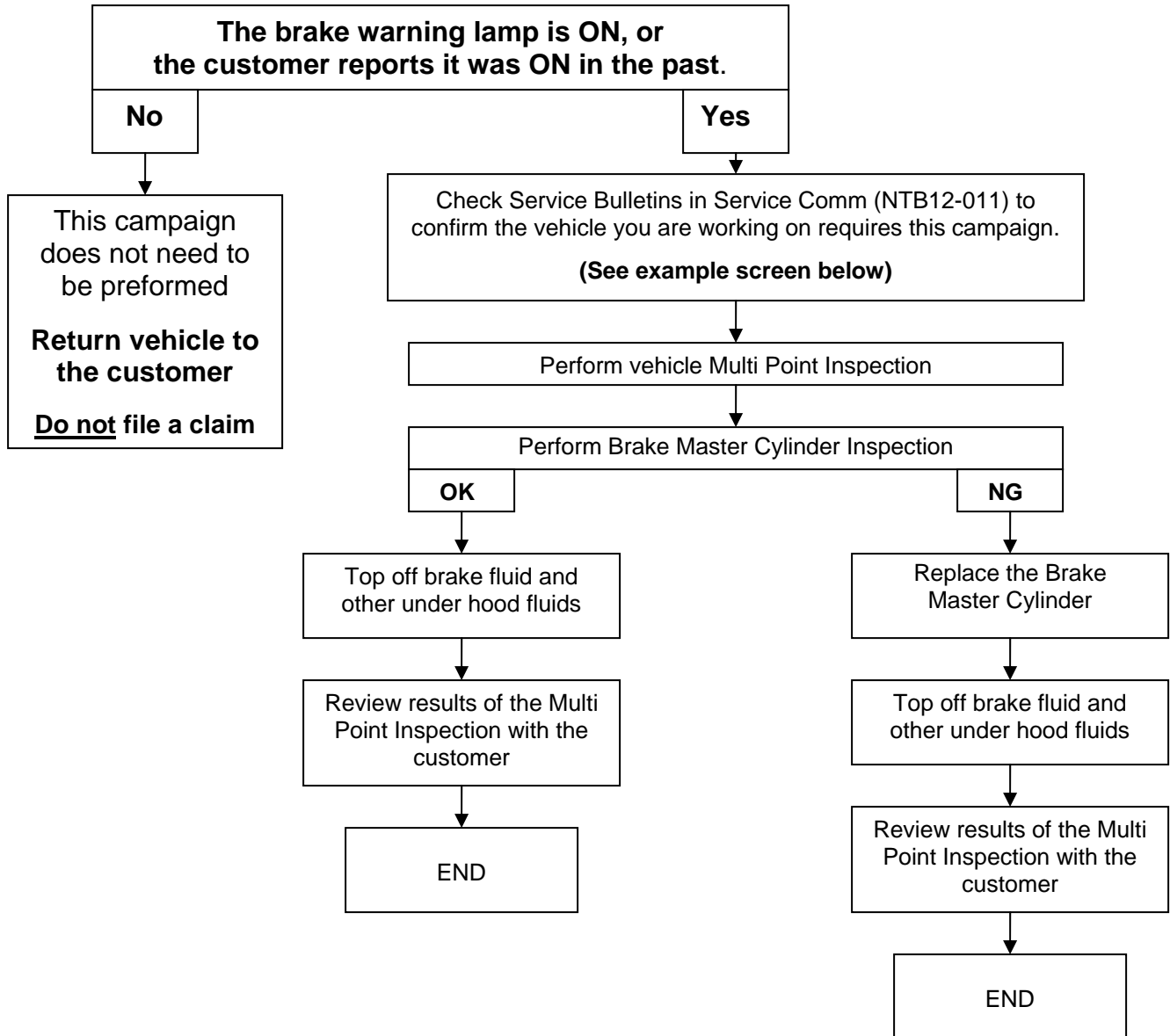

Example Screen

```

    01/09/13 13:31:53          S E R V I C E - C O M M
    PRIMARY DATA            SERVICE BULLETINS                CICSWB06
    09 ALT 2.5 S CVT        NMC MODEL: 05719          VIN: N1AL1195N48832
    MANUFACTURE DATE: 02/18/09  PLANT: CANTON,MS.
    AUTOMATIC EMISSIONS CERTIFICATION: 50 STAT
    -----
    ----REF----  --POSTED--  -----DESCRIPTION-----
    NTB12-011    2013-01-09  NTB12-011 2007-12 ALTIMA BRAKE MASTER CYL INSPECTION
    APPLIED REMARKS: THIS SERVICE ACTION SHOULD ONLY BE PERFORMED WHEN THE
    BRAKE WARNING LIGHT IS ON. VERIFY THE VEHICLE SERVICE
    HISTORY AS THE REPAIR CAN ONLY BE PERFORMED ONCE.
  
```

REQUIRED SPECIAL TOOL J-49749

- Additional tools can be ordered from TECH-MATE at 1-800-662-2001.

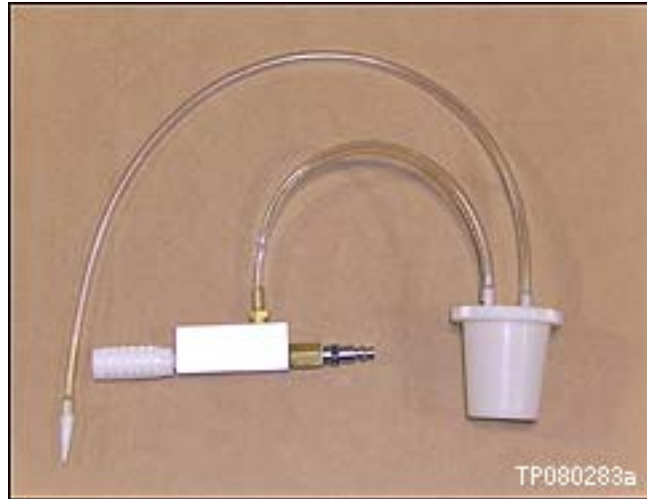

Figure A

SERVICE PROCEDURE

NOTE: Perform this procedure only if the brake warning lamp is ON, or the customer reports the warning lamp was ON in the past.

Brake Master Cylinder Inspection

1. Cover fenders and painted areas to protect them from possible brake fluid splashing.

2. Locate the brake booster vacuum tube.

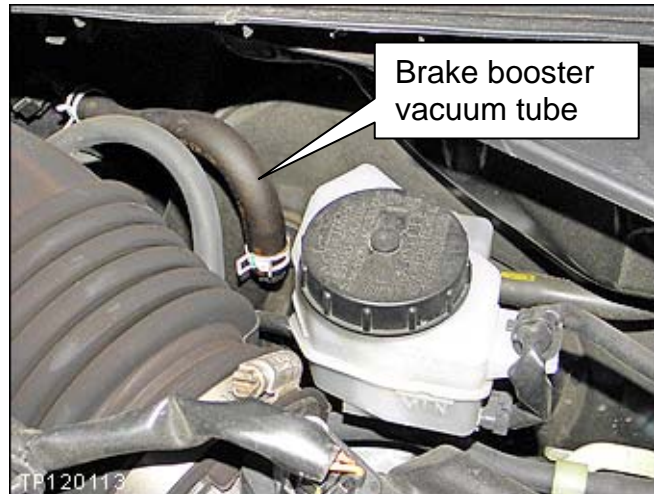

Figure 1

3. Carefully pull the vacuum tube from the brake booster (see Figure 2).

4. Remove the rubber grommet from the brake booster (see Figure 2).

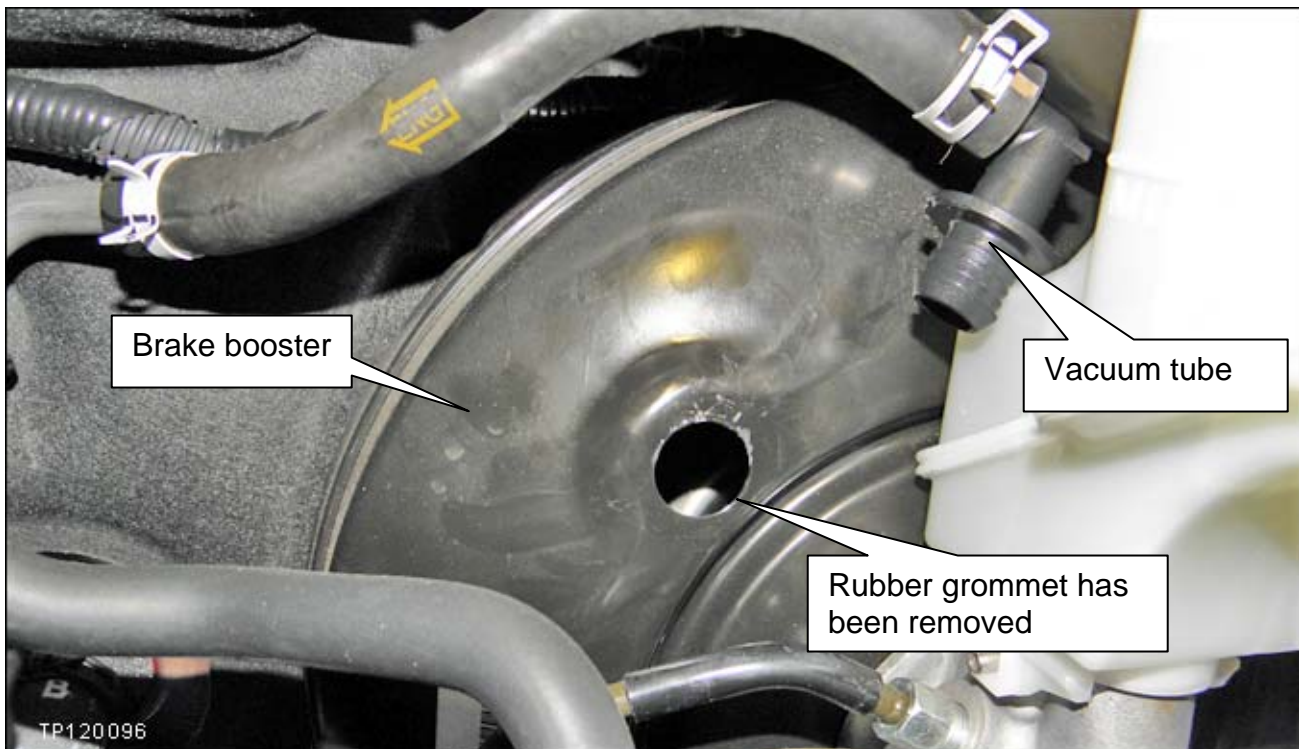

Figure 2

IMPORTANT

- In the next step you will be using special tool J-49749.
- **All residual brake fluid MUST be cleaned / removed from the collection container and tubing before each use.**
- Any brake fluid left in the container or tubing from a previous test will make the next test results invalid.

CAUTION: If brake fluid is splashed on painted surfaces, immediately wipe off with a clean soft cloth and wash with water.

5. Connect Special Tool J-49749 as shown in Figure 3.

- Use shop air supply pressure between 90 and 120 psi.

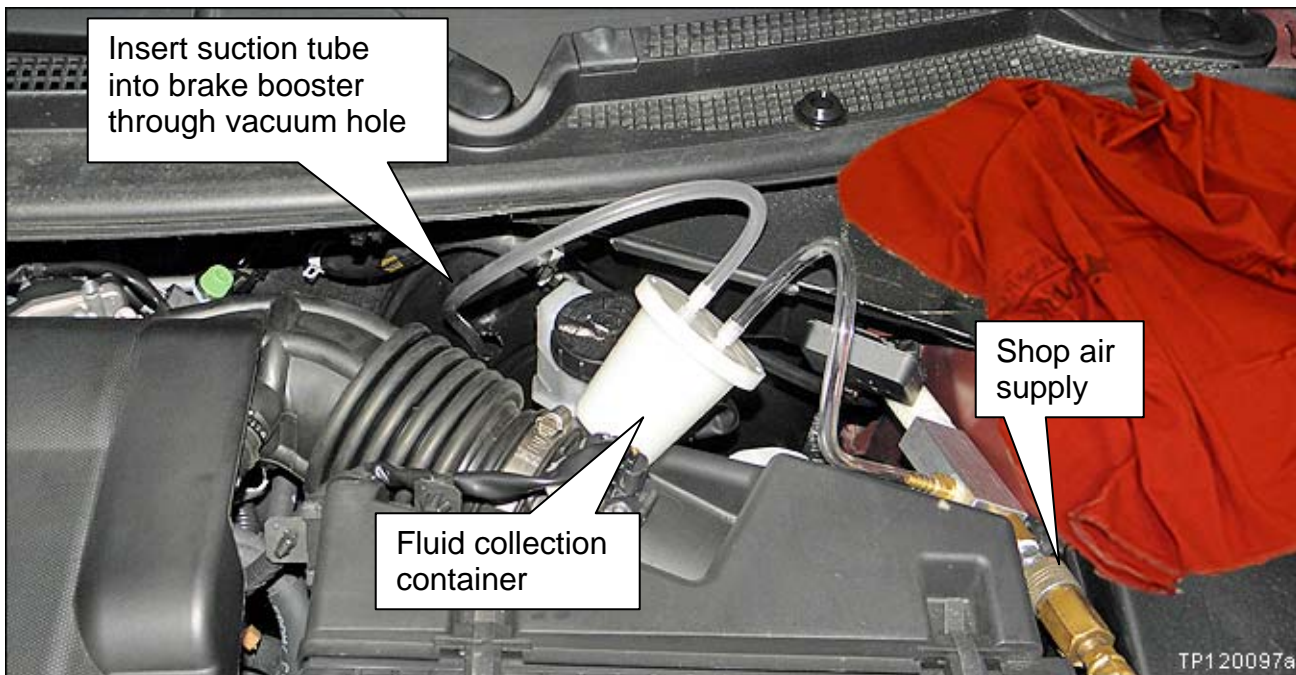

Figure 3

6. Move/position the suction tube inside the brake booster so that any fluid in the lower area of the brake booster is sucked into the collection container.

NOTE: If there is fluid in the lower area of the booster:

- Keep the collection container upright.
- If the collection container fills to within ½ inch of the top, empty it and then continue.
- Continue suction until all of the fluid is removed.

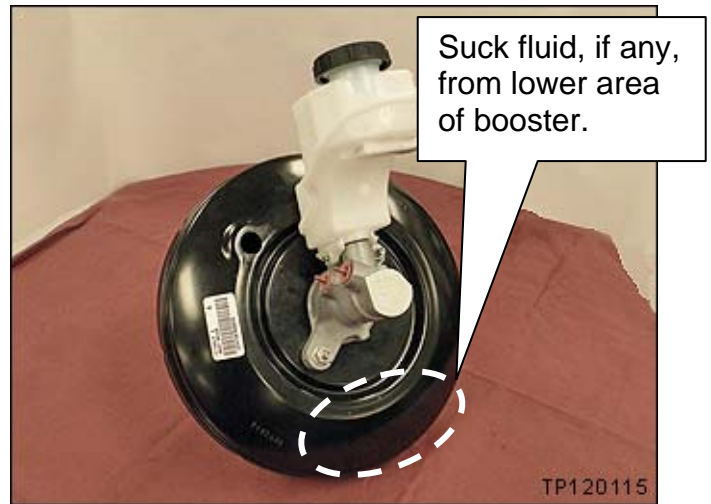

Figure 4

7. After you have removed any / all fluid from the brake booster, disconnect the tool and check the collection container.

OK - No fluid in the container:

- Reinstall all parts removed.
- Make sure the brake fluid reservoir is full.
- Check and fill (top-off) under hood fluids (e.g. washer fluid, coolant, brake fluid).
- Review results of the Multi-Point Inspection with the customer.

NG - Any amount of fluid in the container:

- Replace the Brake Master Cylinder – Instructions starting on the next page.
- Check and fill (top-off) under hood fluids (e.g. washer fluid, coolant, brake fluid).
- Review results of the Multi-Point Inspection with the customer.

NOTE: Once fluid is removed from the booster, the booster does not need to be replaced.

IMPORTANT

- Make sure to clean special tool J-49749 after each use.
- **All residual brake fluid must be cleaned / removed from the collection container and tubing before it is used again.**
- Any brake fluid left in the container or tubing from a previous test will make the next test results invalid.

Brake Master Cylinder Replacement

1. Write down the radio station presets.

Presets	1	2	3	4	5	6
A						
B						
C						
SAT						

2. If equipped, write down the customer settings for the ATC (Automatic Temperature Control) system. (Refer to the Service Manual as needed).
3. Cover fenders and painted areas to protect them from possible brake fluid splashing.

CAUTION: If brake fluid is splashed on painted surfaces, immediately wipe off with a soft cloth and wash with water.

4. Disconnect the negative battery cable.
5. Disconnect the electrical connector from the Mass Air Flow Sensor.

6. Remove the items shown in Figure 5 (4 cyl) or Figure 6 (6 cyl).

4 cylinder engine (QR25DE)

- 1. Air duct hose
- 2. Front air duct
- 3. Air cleaner assembly

A: To electric throttle control actuator.

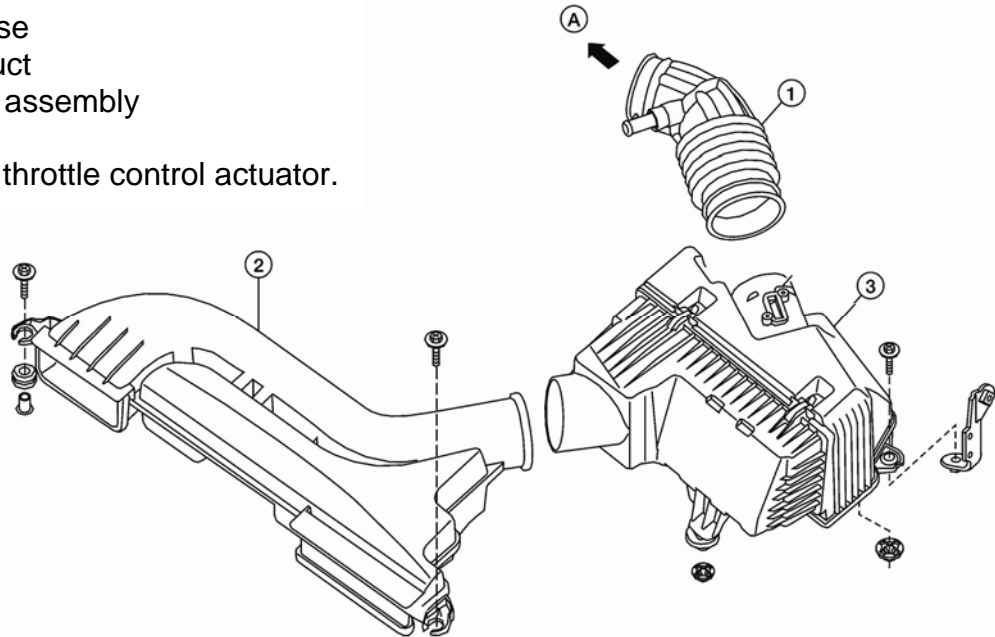

TP120099

Figure 5

6 cylinder engine (VQ35DE)

- 1. Air duct hose
- 2. Duct sub cover
- 3. Front air duct
- 4. Air cleaner assembly

A: To electric throttle control actuator.

NOTE: CVT vent tube will need to be disconnected from the air cleaner assembly as the assembly is removed.

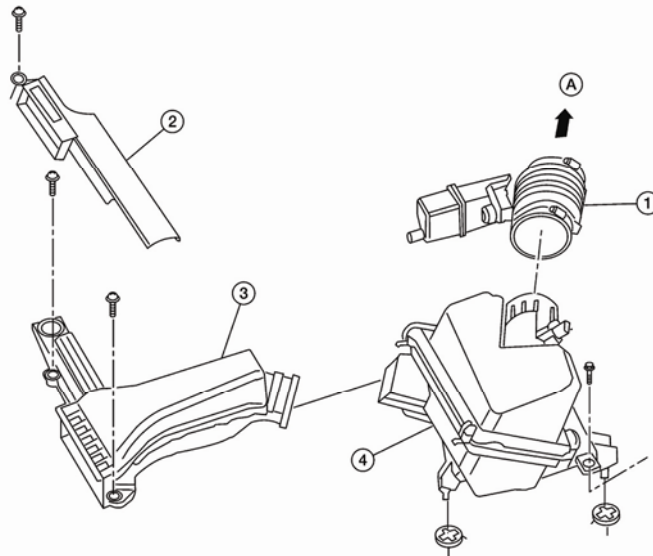

TP120098

Figure 6

7. Disconnect the brake fluid level sensor connector.
8. Disconnect the harness mount from the side of the fluid reservoir.

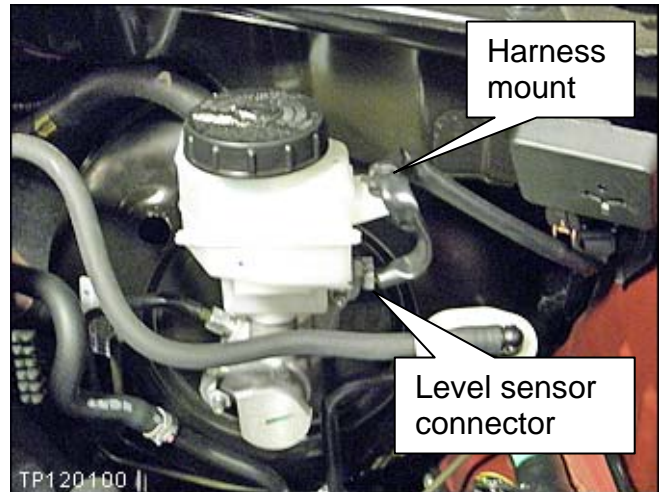

Figure 7

9. Drain the fluid from the brake master reservoir as follows:
 - a. Make sure the parking brake is set.
 - b. Attach a vinyl tube with catch container to a caliper bleed valve.
 - d. Open the bleed valve.
 - e. Slowly pump the brake pedal until the brake fluid reservoir is empty.

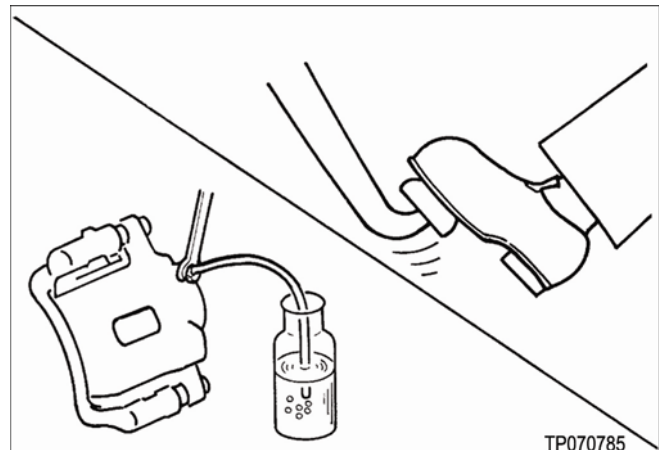

Figure 8

CAUTION:

- If equipped with manual transmission, do not push the clutch pedal when the reservoir is empty or you will need to bleed the clutch system.
- If brake fluid is splashed on painted surfaces, immediately wipe off with a soft cloth and wash with water.

10. If equipped with manual transmission, remove the fluid supply tube for the clutch master cylinder.

CAUTION: Do Not push the clutch pedal when the reservoir is empty or you will need to bleed the clutch system.

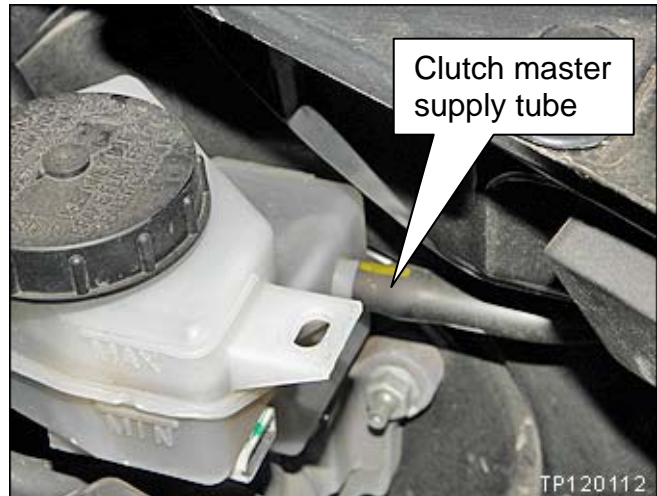

Figure 9

11. Disconnect the 2 brake lines.

12. Remove the 2 attachment nuts for the brake master cylinder and then remove the brake master cylinder.

NOTE: Do not reuse the old brake master cylinder.

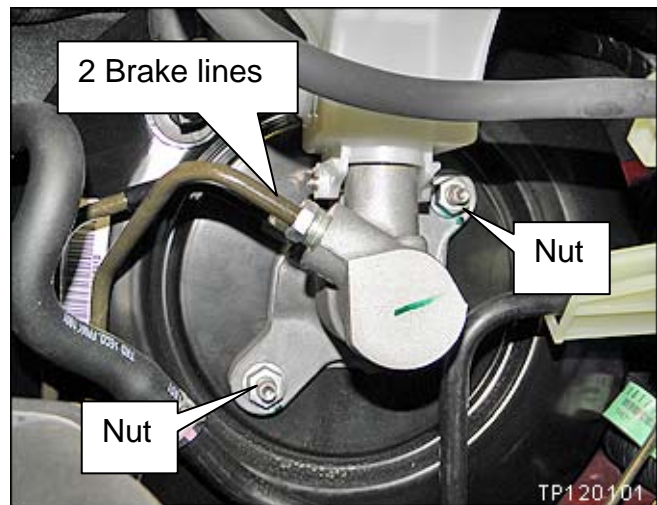

Figure 10

13. Prepare for installation of the new master cylinder:

- Clean the brake booster in and around the hole for the master cylinder.
- Make sure the brake master cylinder to booster seal is in place and fully seated as shown.
- Make sure the primary piston and seal are clean and free of any debris.

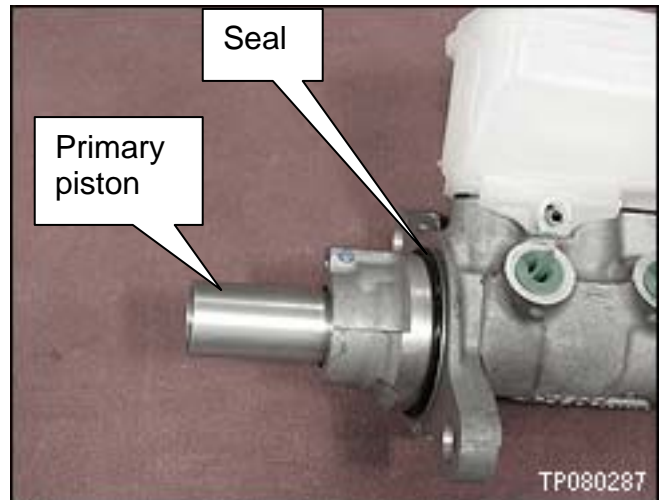

Figure 11

CAUTION:

- **Do Not scratch the master cylinder primary piston.**
- **Do Not allow the primary piston to contact the brake booster during installation.**

14. Install the brake master cylinder and tighten the nuts.

- Nut Torque:
15 N•m (1.5 kg-m, **11 ft-lb**)

15. Attach the brake lines.

- Brake line flare nut torque:
18.2 N•m (1.9 kg-m, **13 ft-lb**)

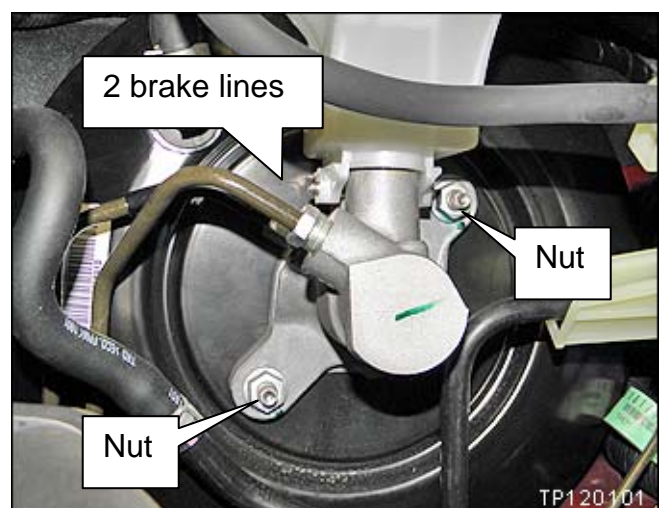

Figure 12

16. If equipped with manual transmission, install the fluid supply tube for the clutch master cylinder.

CAUTION: Do Not push the clutch pedal when the reservoir is empty or you will need to bleed the clutch system.

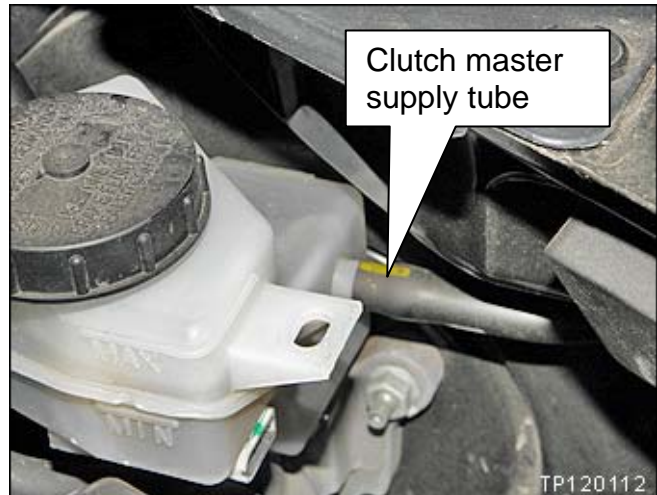

Figure 13

17. Re-connect the brake fluid level sensor connector.

18. Re-connect the harness mount to the side of the fluid reservoir.

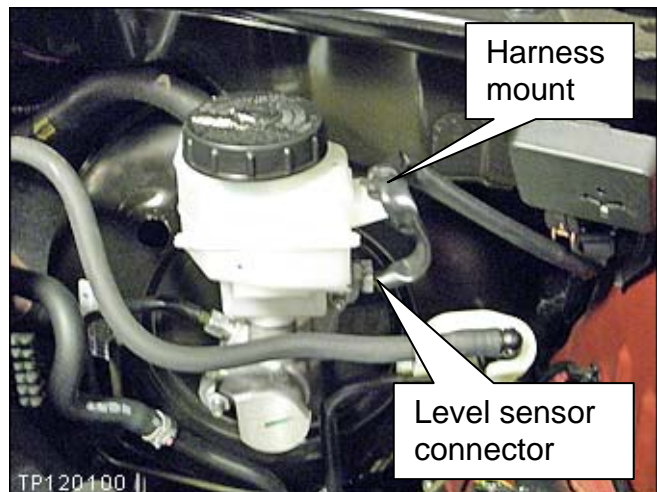

Figure 14

19. Make sure the rubber grommet and vacuum tube are installed into the brake booster.

20. Re-install the items shown in Figure 5 (4 cyl) or Figure 6 (6 cyl).

4 cylinder engine (QR25DE)

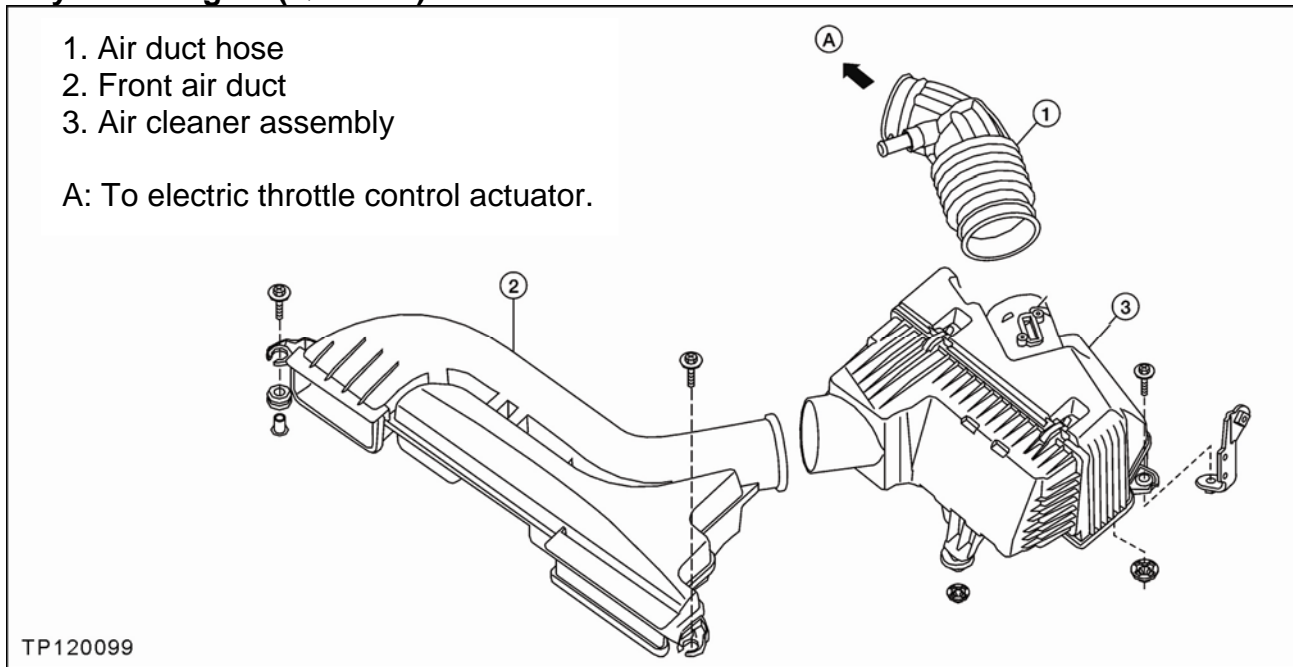

Figure 15

6 cylinder engine (VQ35DE)

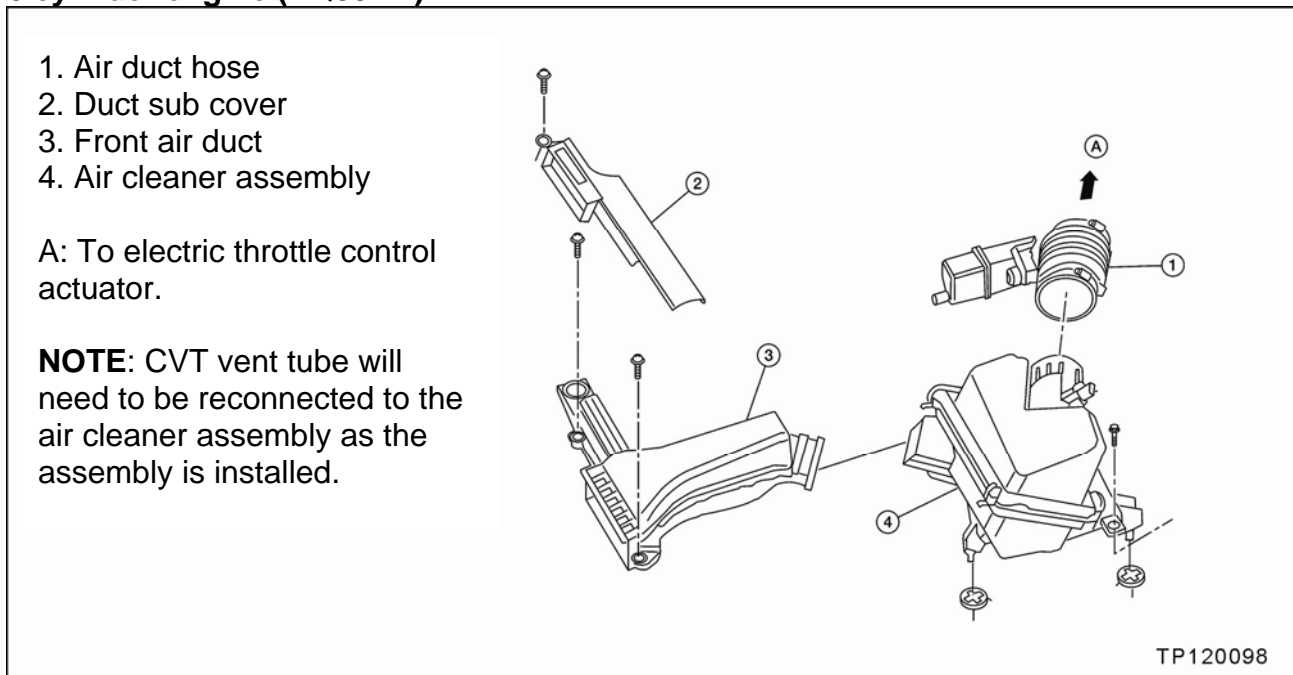

Figure 16

21. Re-connect the electrical connector for the Mass Air Flow Sensor.

22. Bleed air from the brake system as follows:

NOTE:

- Keep brake fluid reservoir filled at least half full while performing the brake bleeding procedure.
- Use a new fresh sealed bottle of genuine Nissan Super Heavy Duty Brake Fluid (P/N 999MP-A4100P).

- Attach a vinyl tube with catch container to the right rear brake caliper or wheel cylinder bleed valve.
- Fully depress brake pedal 4 to 5 times.
- With brake pedal depressed, loosen bleed valve to let the air out, and then tighten it immediately.

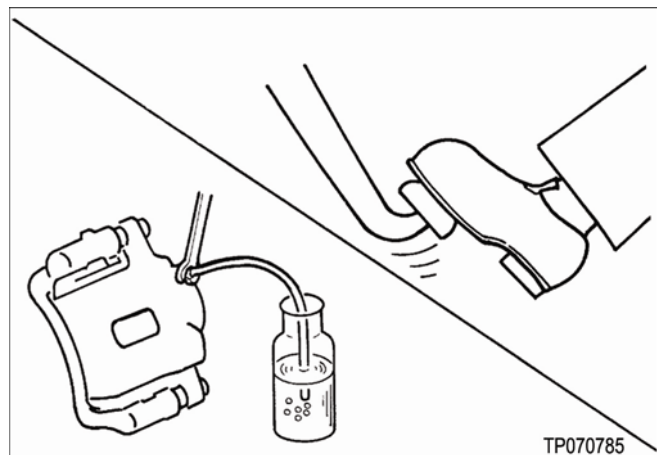

Figure 17

- Repeat steps b and c until no more air comes out.
- Tighten bleed valve. Torque to 8.3 N•m (0.85 kg-m, **73 in-lb**).
- Repeat steps a to e for the other wheels in the following order:

Left Front > Left Rear > Right Front

23. If equipped with manual transmission, make sure the clutch is operating correctly by pumping/cycling the clutch pedal 3 or 4 times.

24. Reset the clock and the radio station presets.

25. If equipped; reset customer's settings for the ATC (Automatic Temperature Control) system. (Refer to the Service Manual as needed.)

26. Initialize auto-up power windows as follows:

- a. Turn the ignition ON (keep the transmission in Park and the parking brake applied).
- b. Close the door.
- c. Operate the power window switch to fully open the window.
- d. Pull UP and continue to pull UP on the power window switch to fully close the window.
- e. Continue pulling the power window switch UP for 4 seconds after glass stops at fully closed position.
- f. Check that auto-up function operates normally.

27. Check and fill (top-off) under hood fluids (e.g. washer fluid, coolant, brake fluid).

28. Review results of the Multi-Point Inspection with the customer.

PARTS INFORMATION

DESCRIPTION	PART NUMBER	QUANTITY
Brake Master Cylinder	<p style="text-align: center;">Use the VIN</p> Refer to the electronic parts catalog (WINFAST or equivalent) to obtain the correct part number	1

CLAIMS INFORMATION

Submit a Campaign (CM) line claim using the following claims coding:

CAMPAIGN (CM) ID #	DESCRIPTION	OP CODE	FRT
PC125	Inspect Brake Master Cylinder	PC1250	0.3 hrs.

OR

CAMPAIGN (CM) ID #	DESCRIPTION	OP CODE	FRT
PC125	Inspect and Replace Brake Master Cylinder	PC1251	1.2 hrs.

Expense Code:

EXPENSE CODE	DESCRIPTION	MAX. AMOUNT
006	Brake Fluid	\$7.98

Genuine Nissan Super Heavy Duty Brake Fluid (P/N 999MP-A4100P) is available through the Nissan Maintenance Advantage program: Phone: 877-NIS-NMA1 (877-647-6621). Website order via link on dealer portal www.NNAnet.com and click on the "Maintenance Advantage" link

EXPENSE CODE	DESCRIPTION	MAX. AMOUNT
026	Under Hood Fluids	\$3.00

E-Learning courses for this campaign:

Course Audience	Course Title & Code
Service Technicians	Altima Service Campaign-PC125 - SCTN1101A-PC125
Express Service Technicians	Altima Service Campaign-PC125 Express Service - SCTN1101A-PC125ET
Service Advisor	Altima Service Campaign-PC125 Service Advisor - SCTN1101A-PC125SA

OWNER'S LETTER

Dear Nissan Altima Owner:

Nissan is committed to providing the highest levels of product quality and customer satisfaction. With that in mind, we want to bring to your attention important information regarding a service campaign for the brake system on your Nissan Altima vehicle.

REASON FOR SERVICE CAMPAIGN

As your brake pads wear over time, the brake fluid level in the master cylinder reservoir will drop and may cause the brake warning lamp to illuminate. Although this is a normal condition, there has been concern that the brake warning lamp illumination may be caused by a slow fluid leak over time. Nissan wants to address this concern to ensure your continued satisfaction and confidence in your vehicle and confirm that no other brake system issues exist.

WHAT NISSAN WILL DO

Nissan is conducting a voluntary service campaign to check pad wear and for fluid leaks from the master cylinder. As part of this service, the brake fluid will also be filled to its maximum level. This inspection and fluid top off will be performed free of charge. Only a small percentage of vehicles eligible for an inspection may have a low brake fluid level caused by a slow leak. If a leak is detected in the master cylinder, the master cylinder will be replaced with a new one free of charge for parts and labor. The brake pad inspection will be performed to determine the remaining pad life in your brake pads, however, brake pads are a normal wear item and replacement is not covered.

WHAT YOU SHOULD DO

You will only need to bring your vehicle to a Nissan dealer for an inspection if the brake warning lamp in your Altima is illuminated (with engine running and parking brake OFF). Please contact your Nissan dealer at your earliest convenience to arrange an appointment. This inspection service should take about an hour or less to complete, but your Nissan dealer may require your vehicle for a longer time based upon their service department schedule. To minimize your inconvenience, it is important that you have an appointment before bringing your vehicle to the Nissan dealer for service. Note that the brake pad inspection, fluid top off and master cylinder replacement (if necessary) are the only services that qualify for free repair under this campaign. Please bring this notice with you to your service appointment. Instructions have been sent to your Nissan dealer.

If you have previously paid to have a master cylinder replaced out of warranty and seek reimbursement, we ask that you visit www.NissanAssist.com, download the Reimbursement Claim Form and follow the instructions on the site. If you have additional questions or concerns, please contact your Nissan dealer or our Consumer Affairs office at **(800)-867-7669**. Only the master cylinder is reimbursable under this campaign.

At Nissan we and our dealers work daily to deliver an outstanding ownership experience that will earn your confidence and trust. Thank you for providing us an opportunity to ensure your on-going satisfaction with your Nissan Altima.