



**NUMBER:** 17-001-13

**GROUP:** Rear Suspension

**DATE:** January 25, 2013

*This bulletin is supplied as technical information only and is not an authorization for repair. No part of this publication may be reproduced, stored in a retrieval system, or transmitted, in any form or by any means, electronic, mechanical, photocopying, or otherwise, without written permission of Chrysler Group LLC.*

**THIS SERVICE BULLETIN IS ALSO BEING RELEASED AS RAPID RESPONSE TRANSMITTAL (RRT) 13-006. ALL APPLICABLE SOLD AND UN-SOLD RRT VIN'S HAVE BEEN LOADED. TO VERIFY THAT THIS RRT SERVICE ACTION IS APPLICABLE TO THE VEHICLE, USE VIP OR PERFORM A VIN SEARCH IN TECHCONNECT. ALL REPAIRS ARE REIMBURSABLE WITHIN THE PROVISIONS OF WARRANTY.**

**SUBJECT:**

Rear Air Spring Shield Installation Procedure

**OVERVIEW:**

This bulletin involves the installation of a rear spring shield.

**MODELS:**

2011-2013 WK Grand Cherokee (Russia Only)

**DIAGNOSIS:**

If a customer's VIN is listed in VIP or your RRT VIN list, perform the repair.

**PARTS REQUIRED:**

Qty.	Part No.	Description
1	04877448AB	Shield, Right Air Spring
1	04877449AB	Shield, Left Air Spring
1	52124735AE	Hose Assembly, Right Rear Brake
1	52124736AE	Hose Assembly, Left Rear Brake

**REPAIR PROCEDURE:**

**WARNING:**All pressurized air suspension components contain high pressure air (up to 220 psig). Use extreme caution when inspecting for leaks. Wear safety goggles and adequate protective clothing when inspecting or servicing the air suspension system. A sudden release of air under this amount of pressure can cause possible serious or fatal injury.

**WARNING:**Support the vehicle by supplemental means before performing any work on the air suspension system to prevent the vehicle from changing height. Before any given component is to be serviced it must be deflated. Servicing the air suspension system without supplemental support, or with pressure in the specific component, can cause possible serious or fatal injury.

**CAUTION:** When removing an air line from a component and the air line is to be reused, do not remove the 90° fitting or the brass fitting from the air line. If either is removed, the air line must be replaced. New components have air line fittings attached; however if the original air line is used the original fitting must also be used. Do not remove protective caps or plugs from air lines or components until ready to install the air line to prevent moisture or dirt intrusion. All air line fittings must be hand started to avoid cross threading.

1. With a scan tool, using the routines under the ASCM, perform the following:
2. Select MISC function TAB.
3. Disable the air suspension system.
4. Highlight "SPRING DEFLATE TO RESERVOIR" and select green arrow (START MISC FUNCTION).
5. Select "LEFT REAR AIR SPRING" then "COMPLETE DEFLATE".

**NOTE: Must Perform Step (6) 3 Times To Completely Deflate**

6. Raise the vehicle on a suitable hoist. Refer to the detailed service procedures available in DealerCONNECT> TechCONNECT under: Service Info> 04- Vehicle Quick Reference> Hoisting> Standard Procedure> Hoisting.
7. Remove rear wheels and tire assemblies.

**NOTE: Do not remove the fitting from the air line. During installation the same fitting will be used. If the fitting is removed from the air line, the air line must be replaced.**

8. Disconnect the left rear air spring line([Fig. 1](#)).

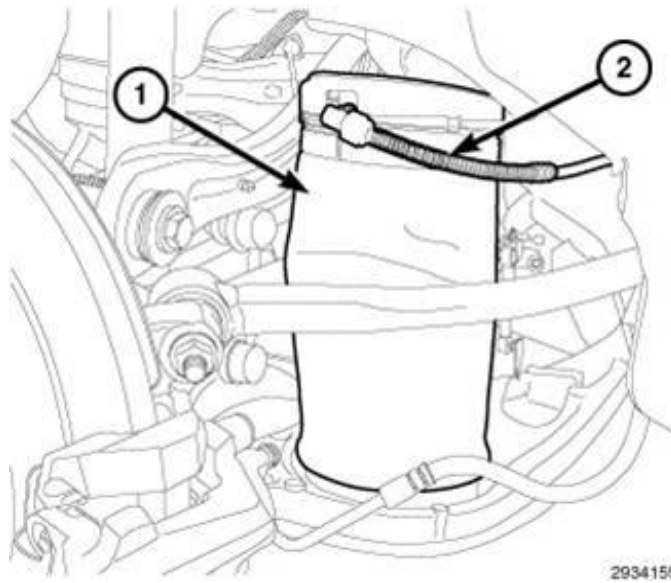

**Fig. 1 Air Spring**

- 1 - Air Spring
- 2 - Air Line

- 
9. To remove the air spring, push down on the air spring to compress, tilt the top out and lift the air spring from the lower control arm between the tension link and camber link(Fig. 2).

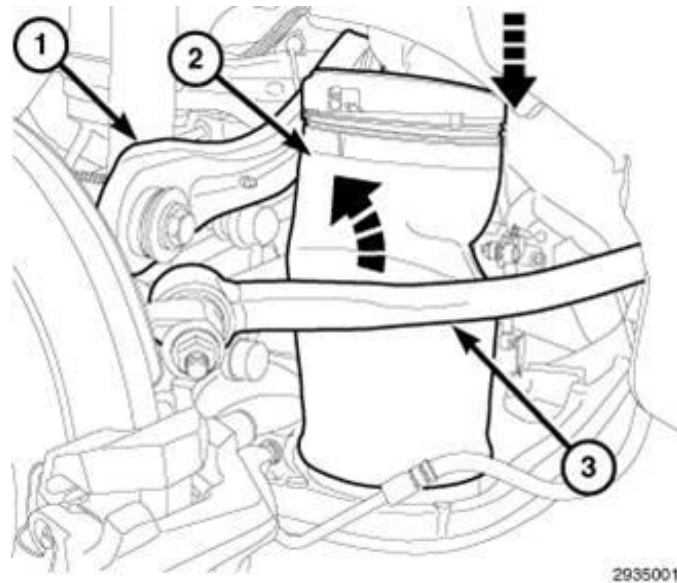

**Fig. 2 Air Spring**

- 1 - Camber Link
- 2 - Air Spring
- 3 - Tension Link

- 
10. Remove the left rear air spring.
  11. Thoroughly remove all mud/dirt/debris from the lower control arm spring seat.

**NOTE: After removal of the rear air spring, the air spring shield may now be installed into the control arm spring seat. A properly installed air spring shield is held in place during vehicle operation by the air spring, no additional fasteners, clips, or adhesives should be used for installation.**

12. Position the air spring shield into the lower control arm spring seat by lining up the piloting feature on the shield with the control arm (Fig. 3) and (Fig. 4).

**NOTE: Special care must be taken to ensure that the shields are not installed on the incorrect sides of the vehicle. Refer to L and R markings on the shield to ensure correct installation. The base of the shield should sit neatly in the spring seat, shields installed on the incorrect vehicle side will not seat properly.**

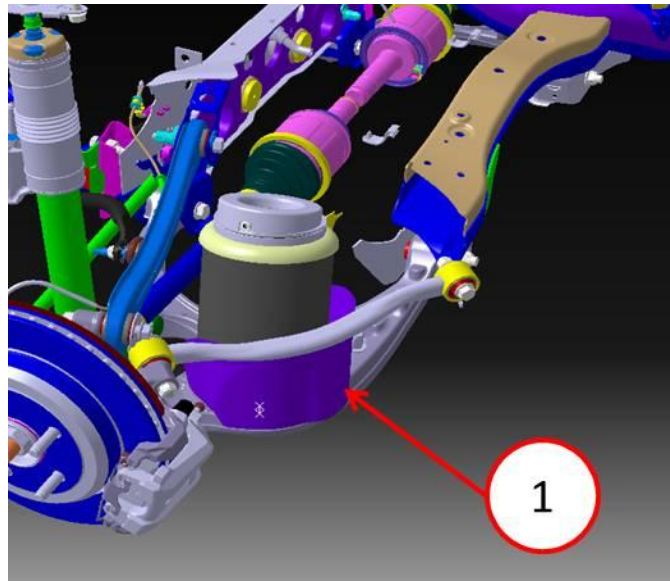

**Fig. 3 Air Spring**

1 - Shield

---

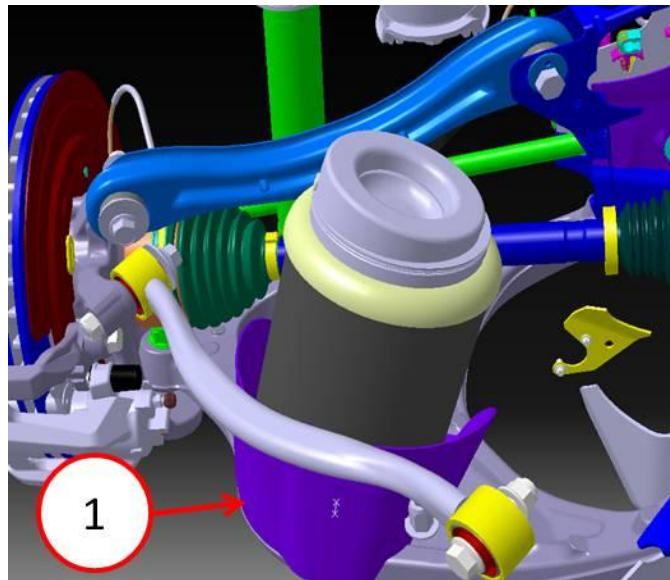

**Fig. 4 Air Spring**

1 - Shield

---

13. Install the left rear air spring.
14. Install air line, left rear.
15. Using the wiTECH application inflate the rear spring air bag.

16. Highlight "FILL SPRING FROM RESERVOIR" and select green arrow (START MISC FUNCTIONS)
17. Select "LEFT REAR AIR SPRING" then "SHORT TIME FILL"

**NOTE: Must Perform Step (17) 3 Times To Completely Deflate**

18. Disconnect the right rear air spring air line (Fig. 1).

**NOTE: Do not remove the fitting from the air line. During installation the same fitting will be used. If the fitting is removed from the air line, the air line must be replaced.**

19. To remove the air spring, push down on the air spring to compress, tilt the top out and lift the air spring from the lower control arm between the tension link and camber link (Fig. 2).
20. Remove the right rear air spring.
21. Thoroughly remove all mud/dirt/debris from the lower control arm spring seat.
22. Position the right air spring shield into the lower control arm spring seat by lining up the piloting feature on the shield with the control arm (Fig. 3) and (Fig. 4).
23. Install the right rear air spring.
24. Install air line, right rear
25. Using the wiTECH application inflate the rear spring air bags.
26. Highlight "FILL SPRING FROM RESERVOIR" and select green arrow (START MISC FUNCTIONS).
27. Select "RIGHT REAR AIR SPRING" then "SHORT TIME FILL".
28. Check and fill brake fluid reservoir if required.
29. Install brake pedal prop rod.
30. Remove and replace the left rear brake hose to caliper.

**NOTE: Install the banjo bolt and tighten to 30 N·m (22 ft. lbs.) torque.**

31. Remove and replace the right rear brake hose to caliper.

**NOTE: Install the banjo bolt and tighten to 30 N·m (22 ft. lbs.) torque.**

32. Remove the brake pedal prop rod.
33. Bleed the rear brakes by following the detailed service procedures available in DealerCONNECT/TechCONNECT, Refer TO Group 05 > Brakes > Brakes > Standard Procedure.
34. Using the wiTECH application completely inflate the rear air springs.
35. Select ASCM icon.
36. Select MISC function TAB.
37. Highlight "Fill SPRING from RESERVOIR" and select green arrow (START MISC FUNCTION).
38. Select "LEFT REAR AIR SPRING" then "COMPLETE FILL".
39. Highlight "Fill SPRING from RESERVOIR" and select green arrow (START MISC FUNCTION).
40. Select "RIGHT REAR AIR SPRING" then "COMPLETE FILL".
41. Highlight "MEASURE SYSTEM AIR MASS" and select green arrow (START MISC FUNCTION).
42. Clear any stored DTC's.

**POLICY:**

Reimbursable within the provisions of the warranty.

**TIME ALLOWANCE:**

<b>Labor Operation No:</b>	<b>Description</b>	<b>Amount</b>
02-30-02-90	Air Spring Shield and Brake Hose Installation	1.2 Hrs.

**FAILURE CODE:**

ZZ	Service Action
----	----------------