

## SERVICE CAMPAIGN BULLETIN

**CAMPAIGN REF:** 028  
**TITLE :** Module Software Platform Update to 12  
**DOCUMENT # :** 11 M 064  
**AFFECTED VEHICLES :** 12C Coupe and Spider

**SITUATION :** Quality Engineering at McLaren Automotive have released a new software platform for the 12C

The most noticeable changes of this software are;

- New procedure for Oil level acquisition.
- Odometer back-up to improve robustness.
- Chinese language is now supported in the instrument cluster menu.
- Improved Suspension Displacement Sensor Calibration Sequence.
- New PCCU Sequence Airbrake Contamination Cleaning.
- DTC added for Real Time Clock.
- Improved Engine cover and Luggage compartment Latch drive logic.

**PROCEDURE :** It is necessary to update the software on all vehicles within your Aftersales car parc, both when carrying out Pre-Delivery Inspections (PDI) and at the next service centre visit.

MODULE	NEW SOFTWARE PART NUMBERS
Instrument Cluster (IC)	11M1180CP.25
Body Controller (BC)	11M1215CP.12
Security Body Controller (SBC)	11M1075CP.18
Heating Ventilation and Air-Conditioning (HVAC)	11A4742CP.16
Powertrain Chassis Control Unit (PCCU)	11M0938CP.22
Engine Control Module (ECM)	11M2493CP.05 European/ROW 11M2490CP.04 Federal 11M2502CP.04 Federal

**REMOVAL:**

1. Please refer to AA-RM-02A02-03-004 - Remove/Install luggage bin – rear.

**Care point:** In order to avoid personal injury and damage to the vehicle, do not connect the positive terminal (+) to the negative terminal (-). Ensure that the connections are secure. Do not place any metal objects near the battery when charging and do not place the Deutronic battery charger directly onto the battery unit.

2. Keep the battery on charge, using a Deutronic battery charger during the software downloading procedure.

**Care point:** Both the driver and passenger windows must be in the fully open position during software downloads.

**Care point:** All software downloads require the vehicle to be in ignition state 5.

**Care point:** During the software download process, it is normal for the instrument cluster displays to extinguish temporarily.

**Care Point:** Ensure vehicle lift is in the lowered position before reprogramming the PCCU. Suspension Displacement Sensor Calibration will fail to complete if the system is not fully lowered.

**Care point:** The vehicle must be positioned on a two post ramp and in the fully lowered position.

**Care point:** The key must be positioned in the driver's seat front pocket, picture below (1).

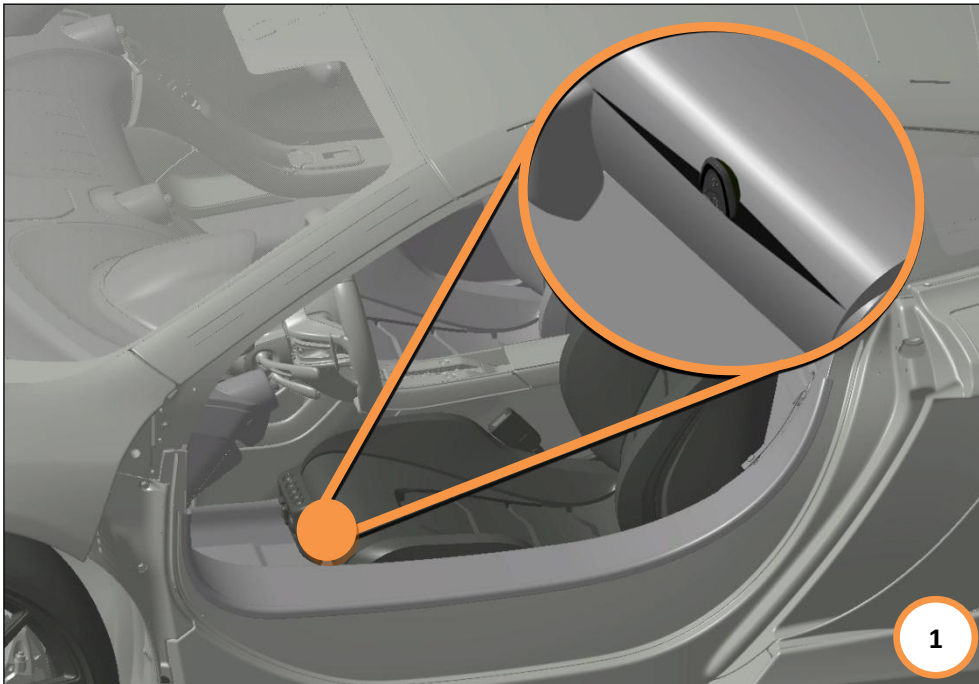

3. Check OBD connector pins 4, 5, 6, 14 and 16, as highlighted below are secure. Loose pins can cause module software download errors. If any of the pins are found to be loose these should be closed up before module reprogramming is carried out (2).

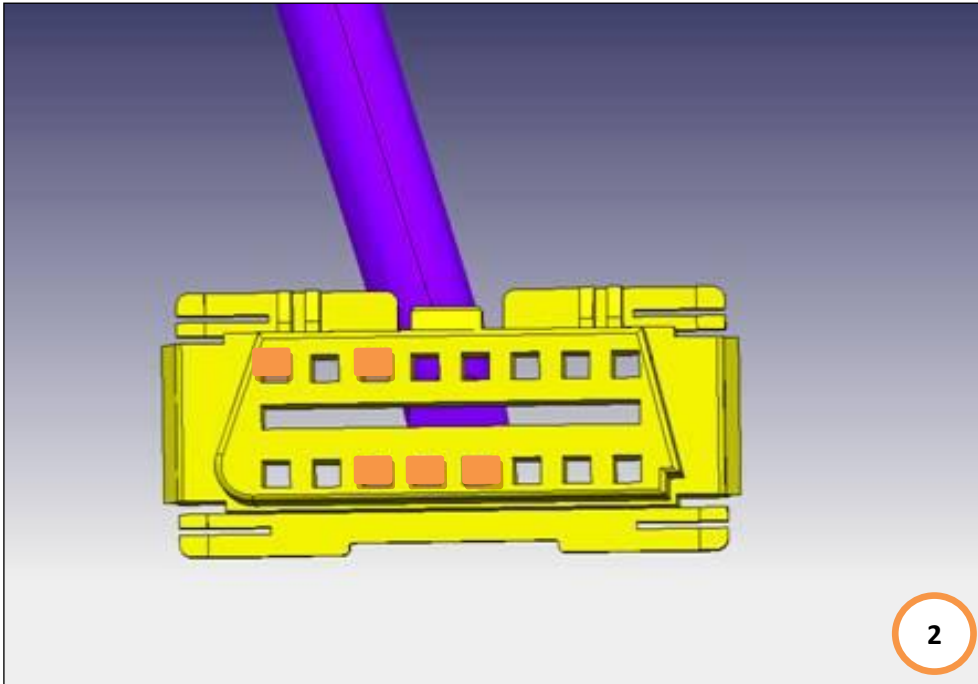

1. Connect the McLaren Diagnostic System (MDS) to the vehicle.
2. Make a note of the ECM (3) and PCCU (4) software levels displayed under the Vehicle Information tab. This information will be required at a later stage of this procedure.

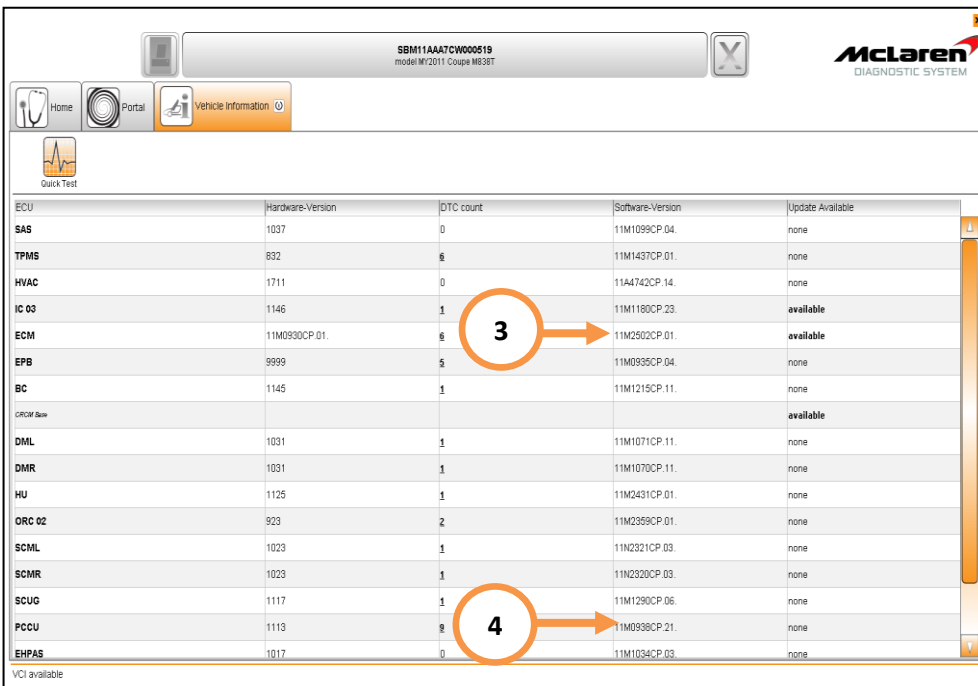

ECU	Hardware-Version	DTC count	Software-Version	Update Available
SAS	1037	0	11M1099CP.04.	none
TPMS	832	6	11M1437CP.01.	none
HVAC	1711	0	11A4742CP.14.	none
IC 03	1146	1	11M1180CP.23.	available
ECM	11M0930CP.01.	6	11M2502CP.01.	available
EPB	9999	5	11M0935CP.04.	none
BC	1146	1	11M1215CP.11.	none
CRCM Base				available
DML	1031	1	11M1071CP.11.	none
DMR	1031	1	11M1070CP.11.	none
HU	1125	1	11M2431CP.01.	none
ORC 02	923	2	11M2659CP.01.	none
SCML	1023	1	11N2921CP.03.	none
SCMR	1023	1	11N2920CP.03.	none
SCUG	1117	1	11M1290CP.06.	none
PCCU	1113	9	11M0938CP.21.	none
EHPAS	1017	0	11M1034CP.03.	none

## IC SOFTWARE UPDATE:

3. Select IC\_03 (1), then Reprogramming (2), select the software level 11M1180CP.25 (3), then proceed to the software download by selecting the tick button (4), followed by the arrow button (5). Select 'YES' to initiate programming.

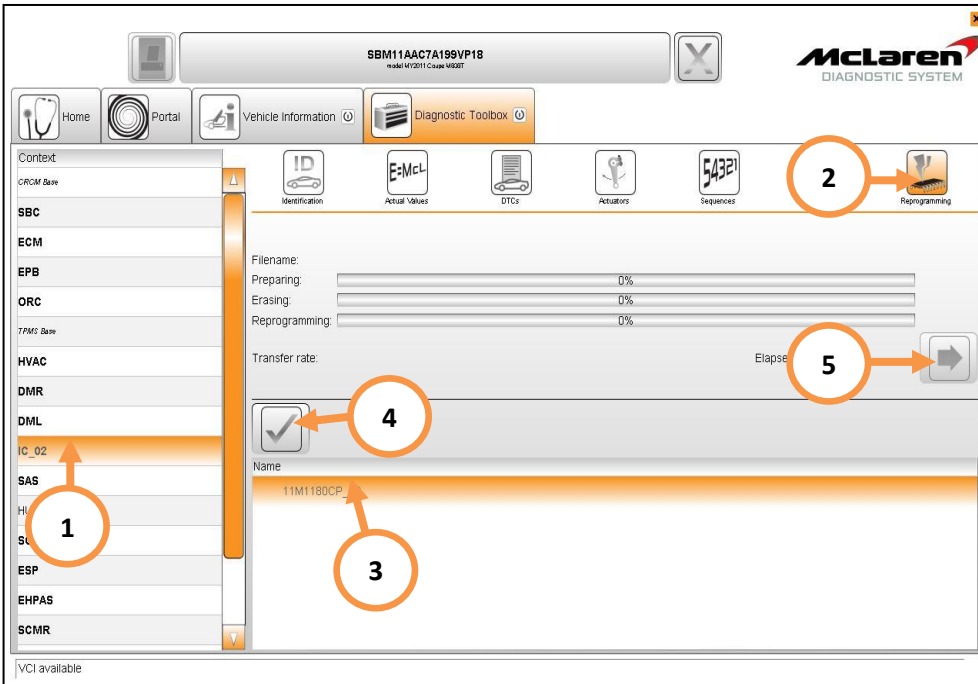

4. Select Sequences (6), select set configuration defaults (7) then select the arrow button to proceed (8).

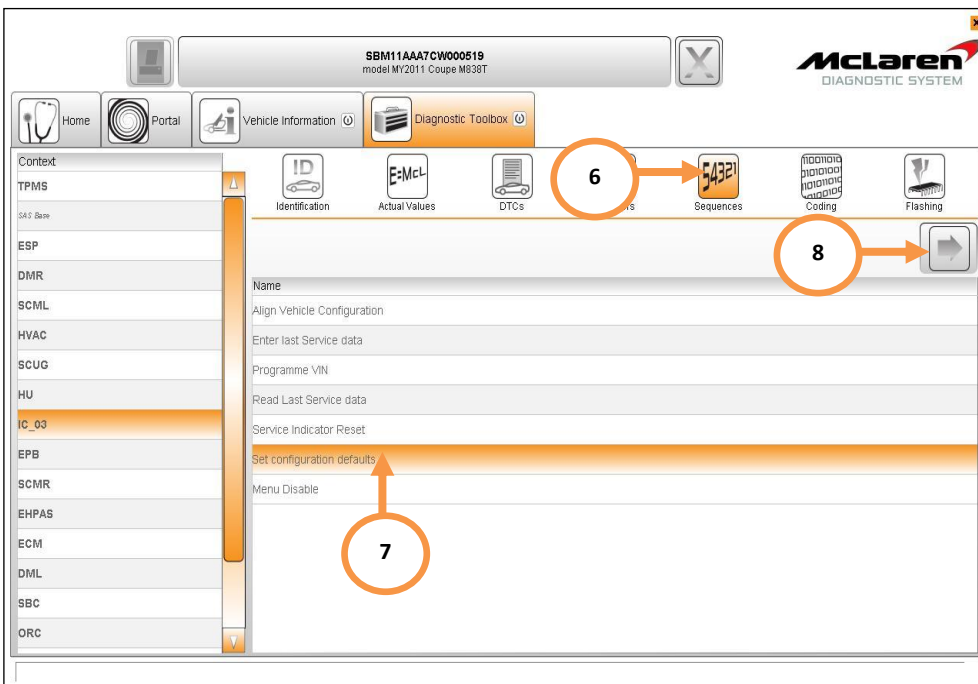

5. Select Align Vehicle Configuration (9), followed by the arrow key (10).

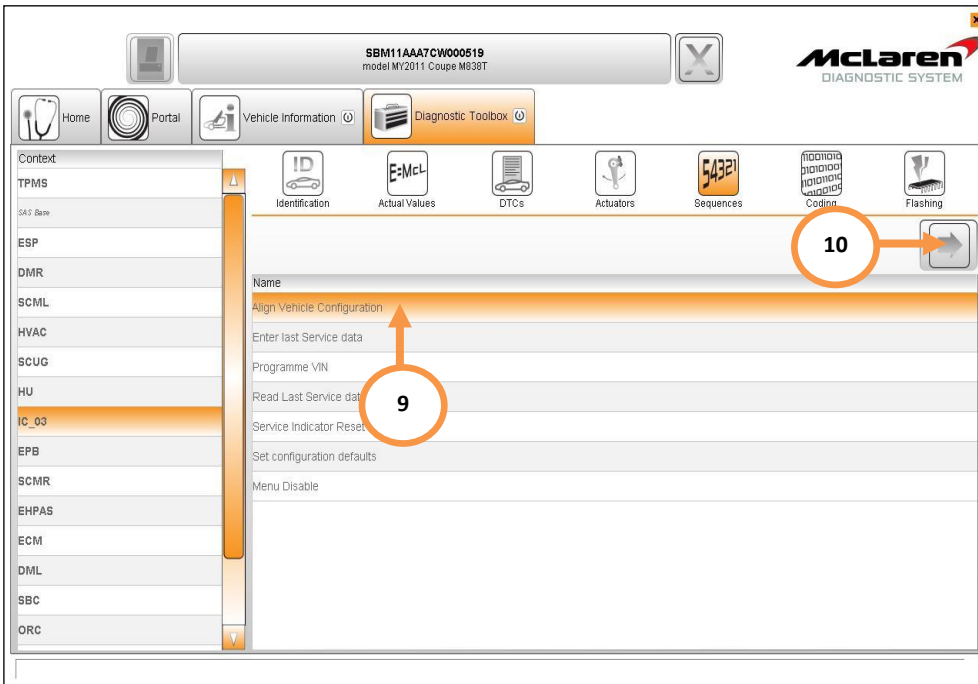

**BC SOFTWARE UPDATE:**

6. Select BC (1), then Reprogramming (2), select the software level 11M1215CP.12 (3), then proceed to the software download by selecting the tick button (4), followed by the arrow button (5). Select 'YES' to initiate programming.

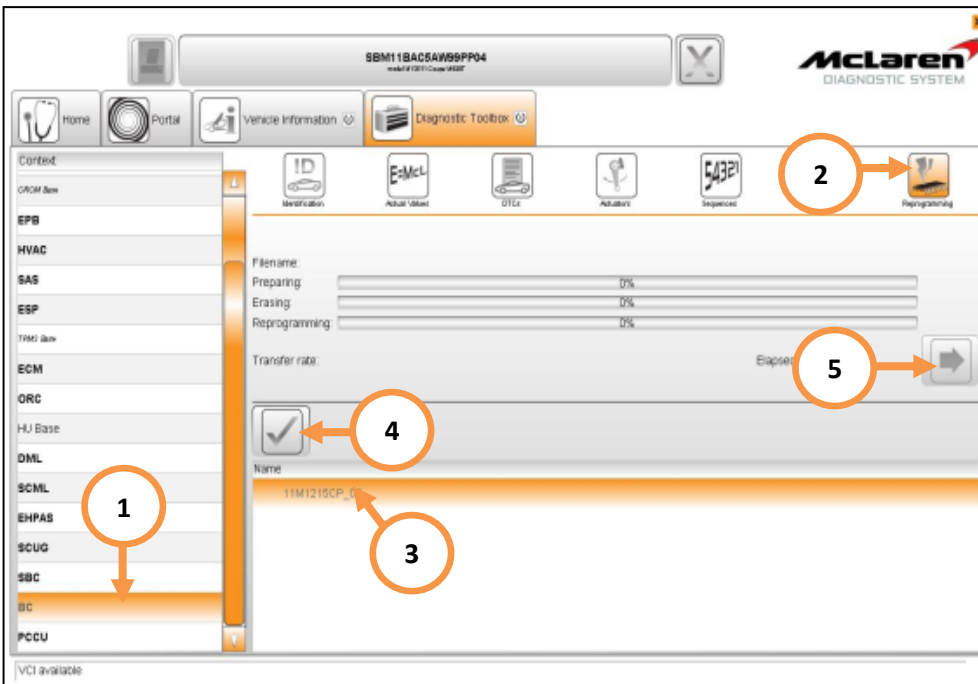

7. Select Sequences (6), then Programme VIN (7), then select the arrow button to proceed (8).

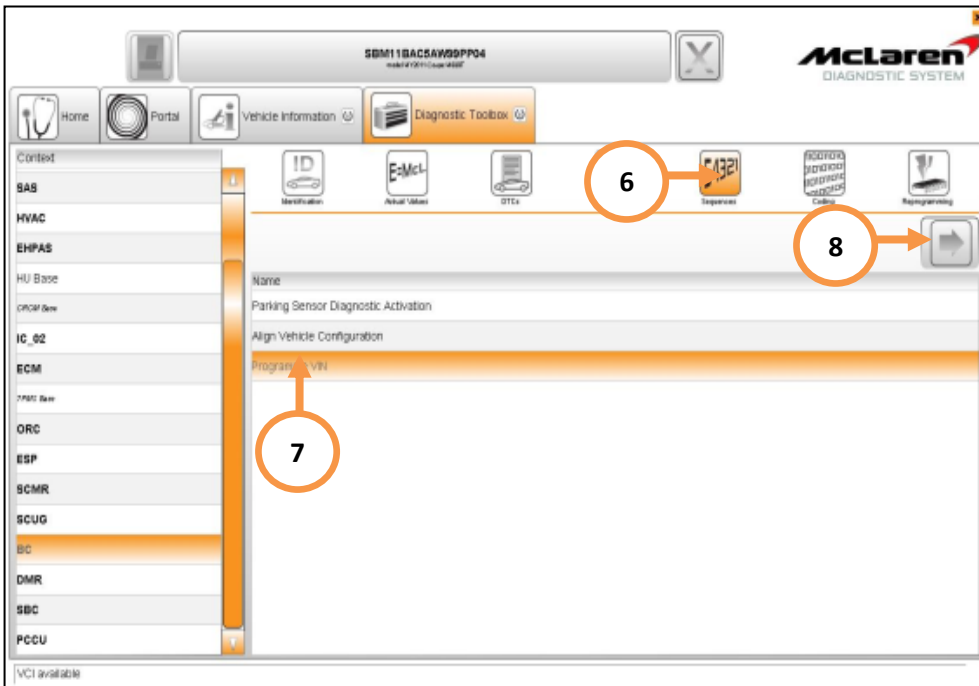

8. Select Align Vehicle Configuration (9), followed by the arrow key (10).

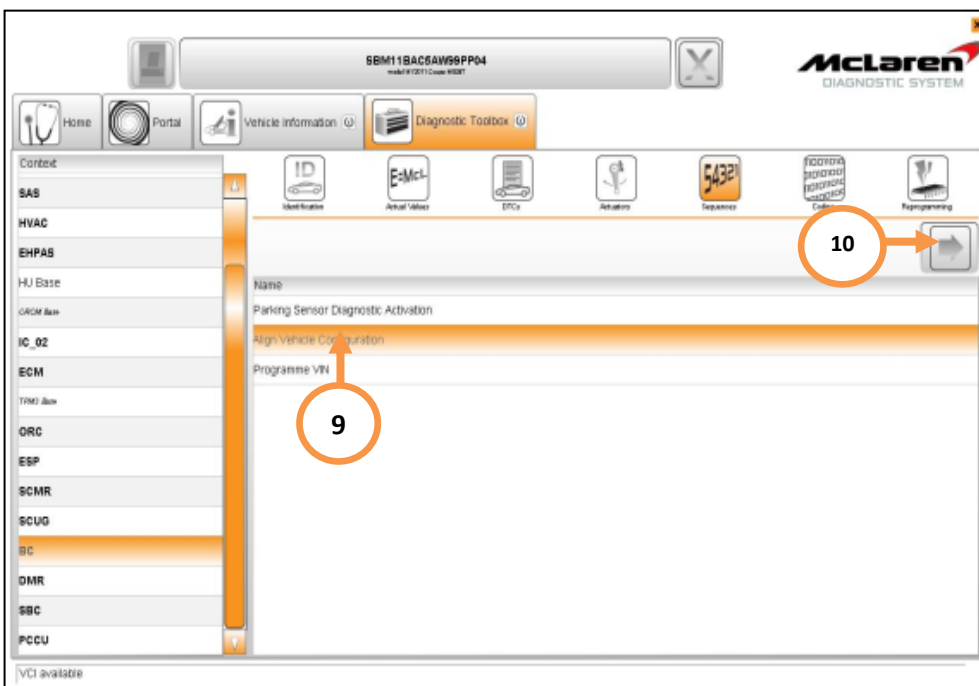

## SBC SOFTWARE UPDATE:

9. Select SBC (1), then Reprogramming (2), select the software level 11M1075CP.18 (3) then proceed to the software download by selecting the tick button (4), followed by the arrow button (5). Select 'YES' to initiate programming.

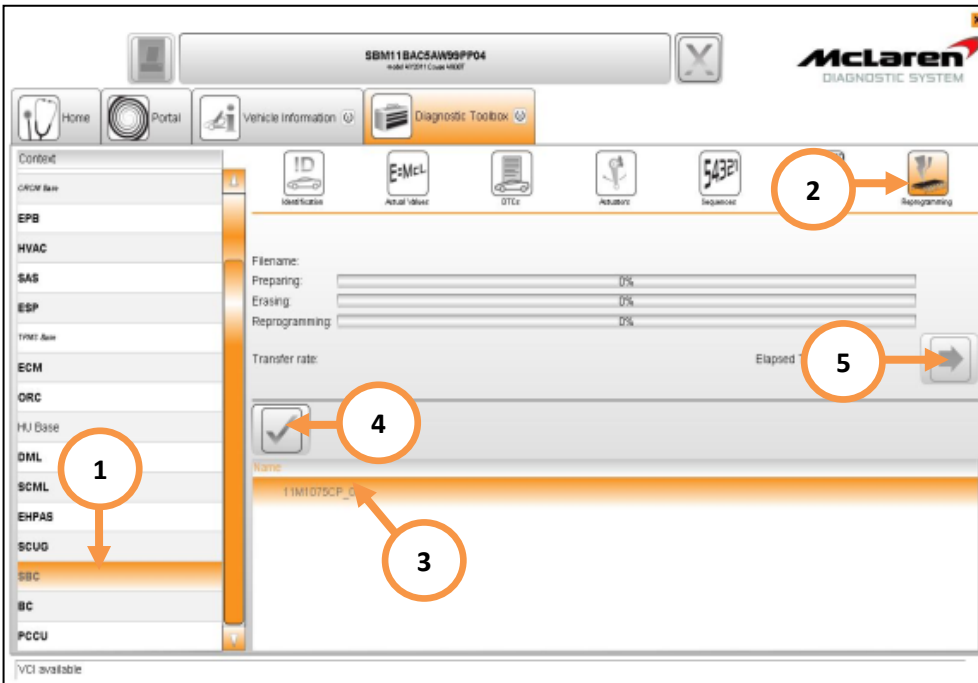

10. When the software download has been successfully completed, programming will force a sleep cycle to occur.

11. After one minute, press the unlock button on the key and then establish the vehicle into ignition state 5 before following the next steps.

12. Select Sequences (6), then Programme VIN (7) then select the arrow button to proceed (8). The programme VIN procedure will force a sleep cycle to occur after the programming is complete.

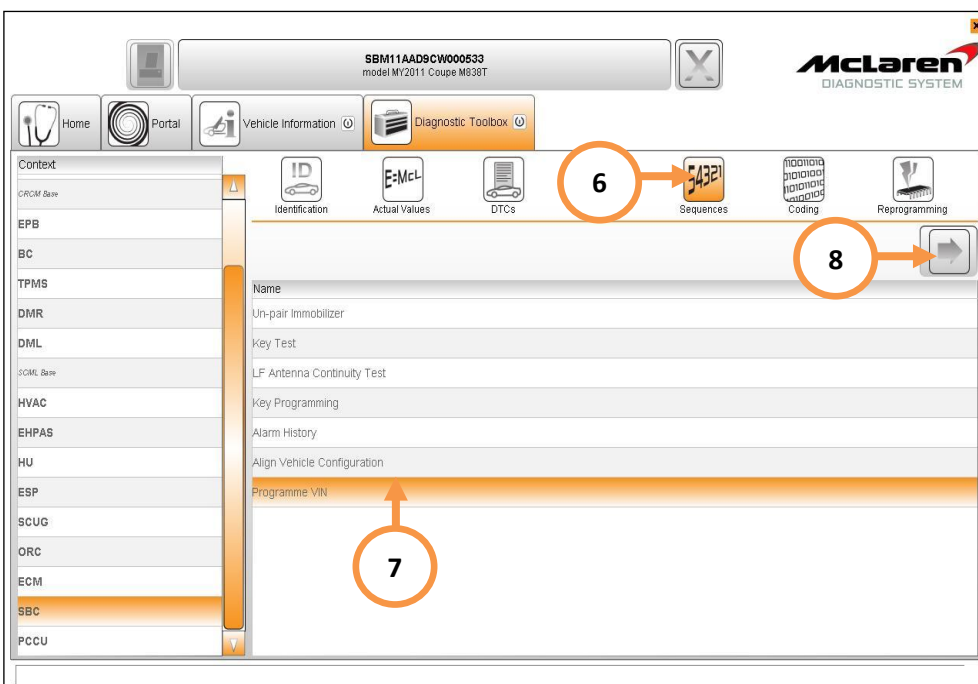

13. Press the unlock button on the key and then establish the vehicle into ignition state 5 before following the next steps.

14. Select Align Vehicle Configuration (9), followed by the arrow key (10).

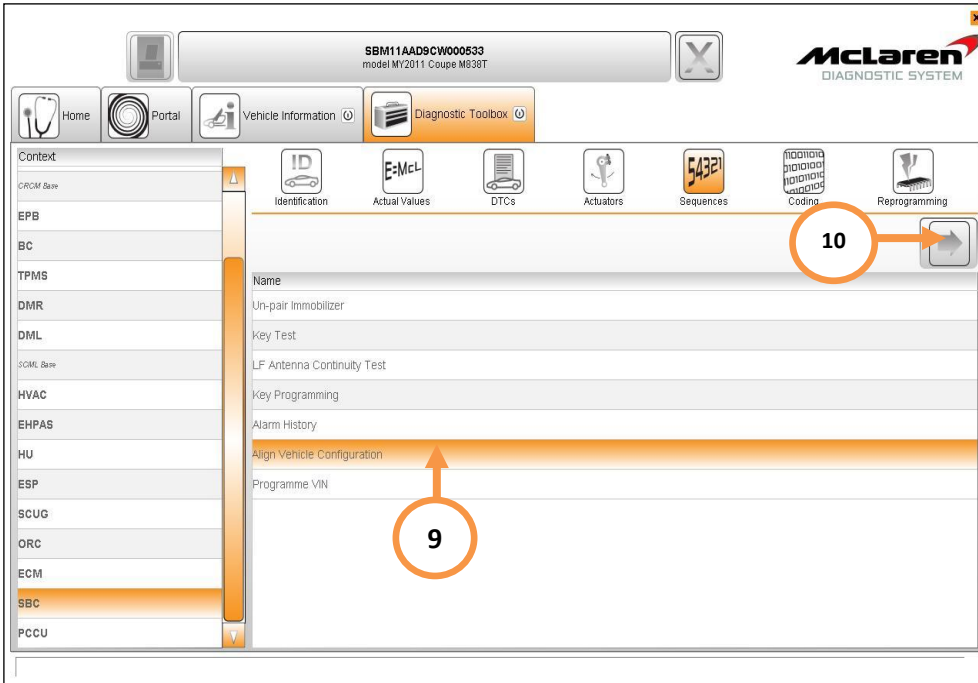

15. Press the unlock button on the key and then establish the vehicle into ignition state 5 before following the next steps.

### HVAC SOFTWARE UPDATE:

16. Select HVAC (1), then select Sequences (2), then Hardware configuration (3), then select the arrow button (4) to proceed.

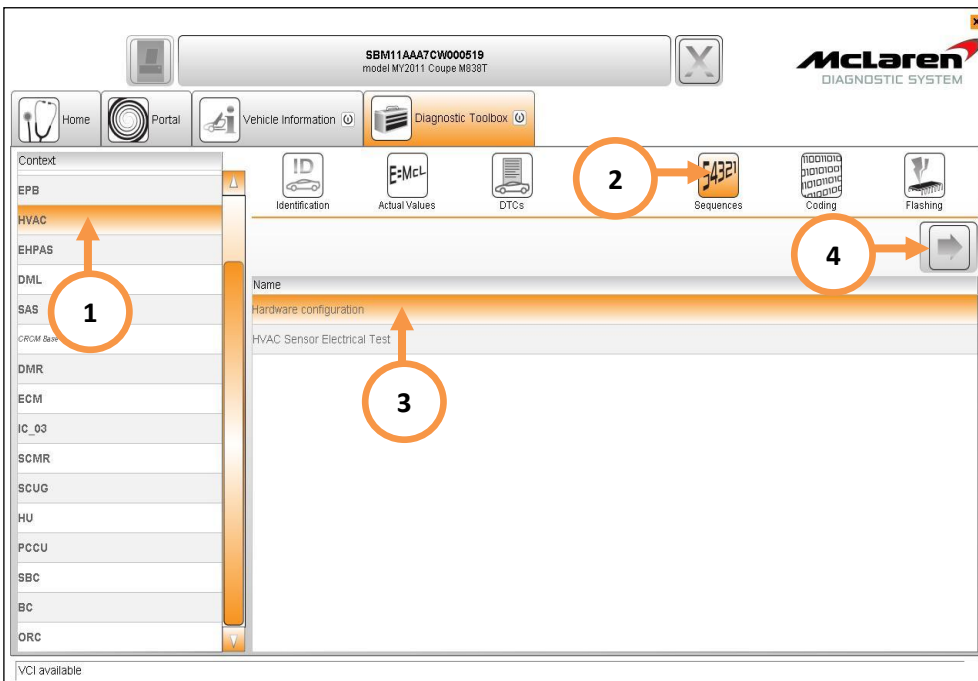

17. The following screen will appear, select Ok (5).

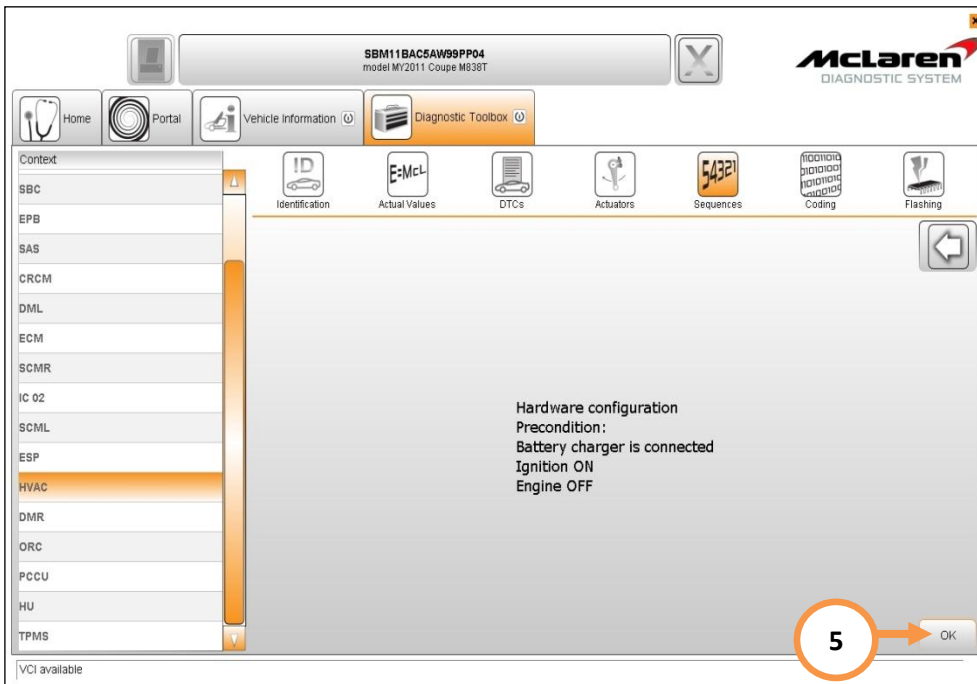

18. HVAC Hardware configuration will be displayed. Make a note of the module configuration. Select Back to abort the sequence (6) and proceed to step 20.

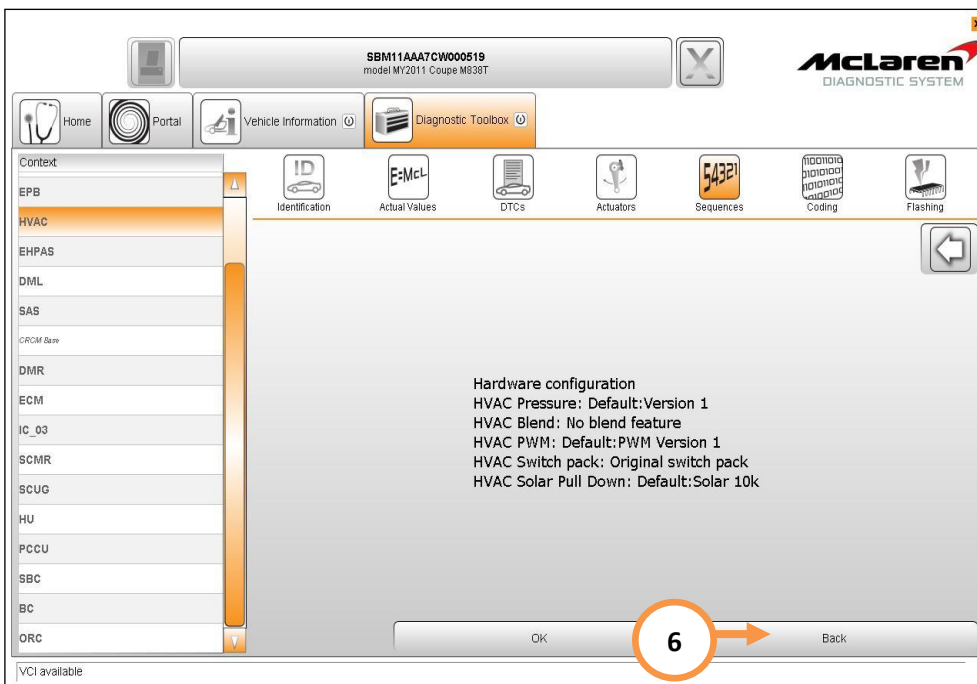

19. If No results found is displayed proceed to reprogram the HVAC module (7).

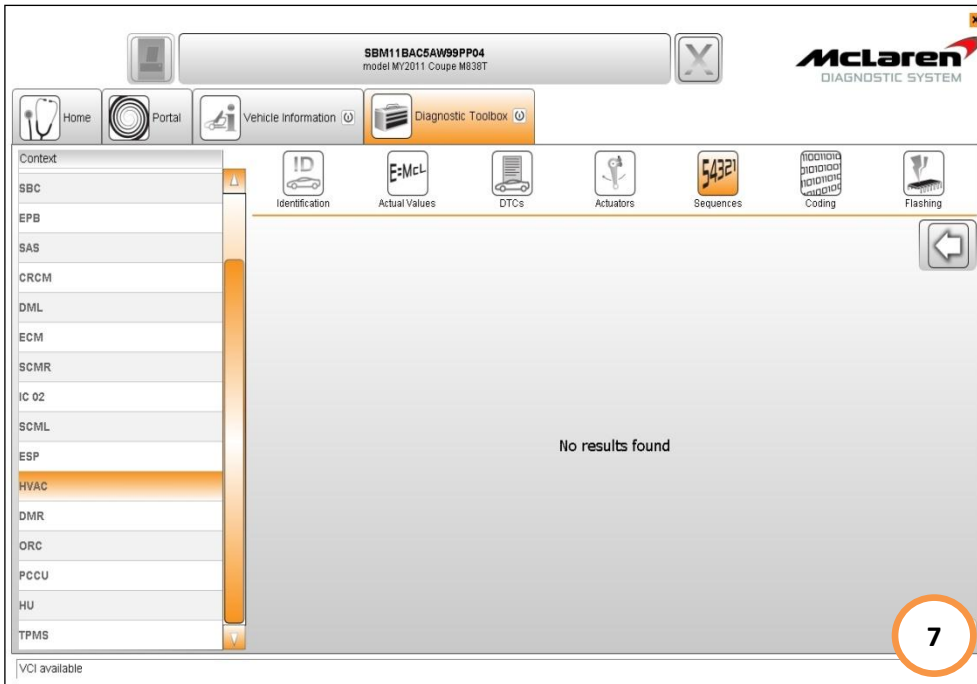

20. Select Reprogramming (8), select the software level 11A4742CP.16 (9), then proceed to the software download by selecting the tick button (10), followed by the arrow button (11). Select 'YES' to initiate programming.

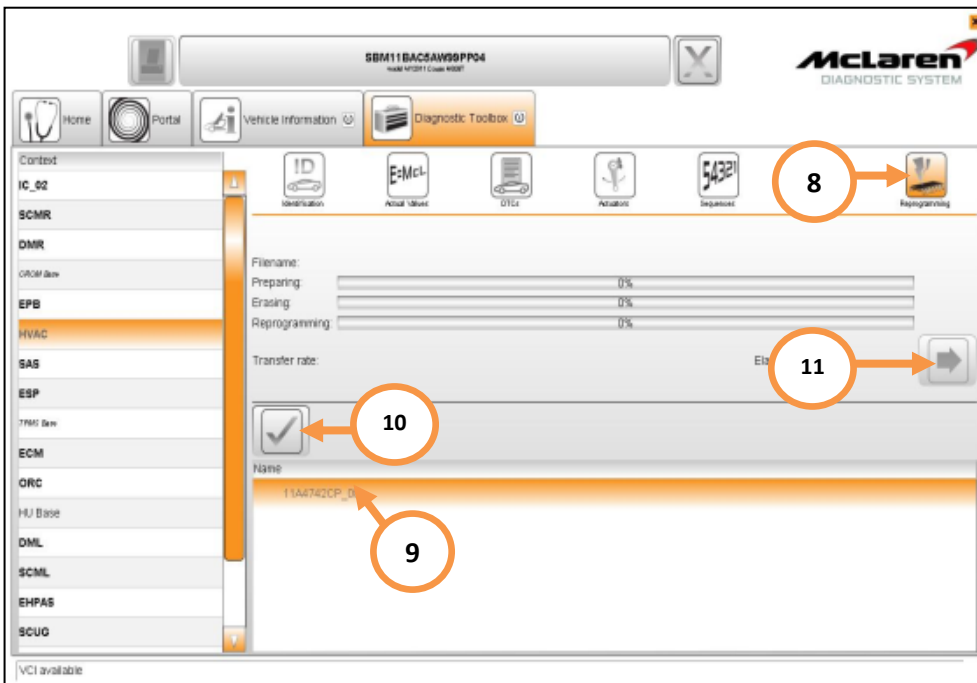

21. After the HVAC has been updated, the HVAC display panel may show the CAL symbol while the system performs a self calibration. When completed, the CAL symbol will disappear from the display.

22. Select Sequences (12), then Hardware configuration (13), then select the arrow button (14) to proceed.

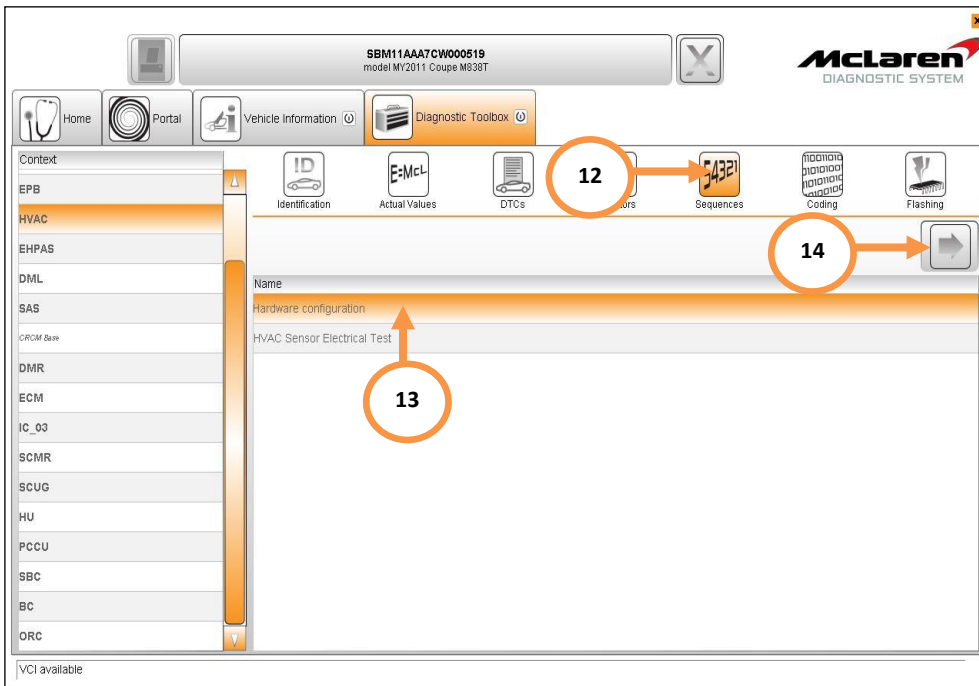

23. The following screen will appear, select OK (15).

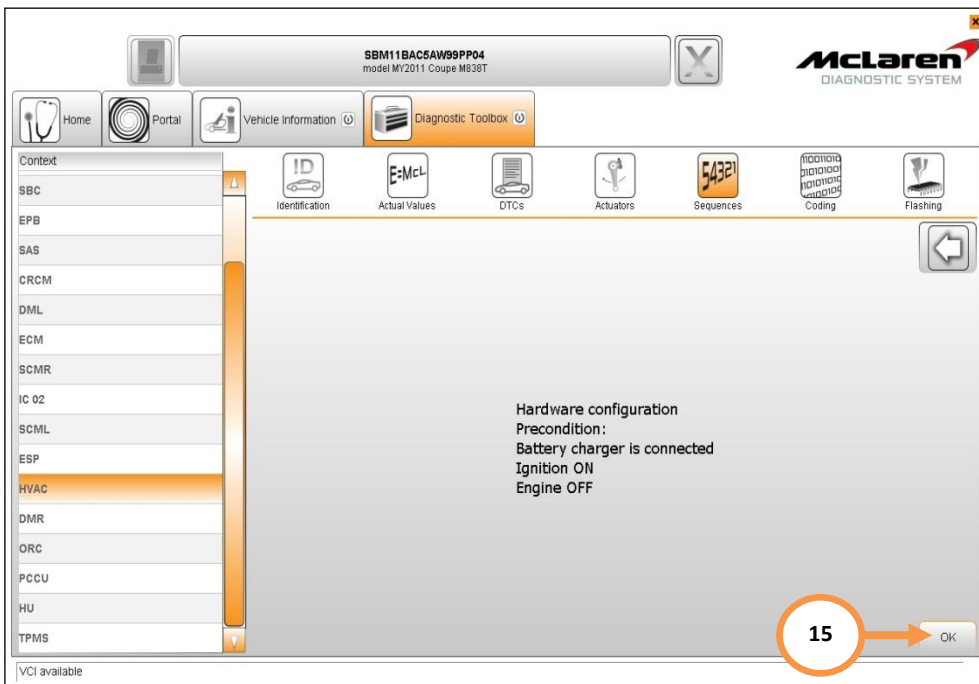

**Care point:** No results found may be displayed after a HVAC module has been reprogrammed.

24. Proceed and configure the HVAC module with the information recorded at step 18.

25. If No results found was displayed at step 19, refer to Service Information Bulletin 11 M 054 - Heating Ventilation and Air Conditioning module configuration procedure for the relevant default values.

26. Repeat steps 17 and 18 to confirm the hardware configuration is correct for the vehicle. Select Back to abort the sequence (16).

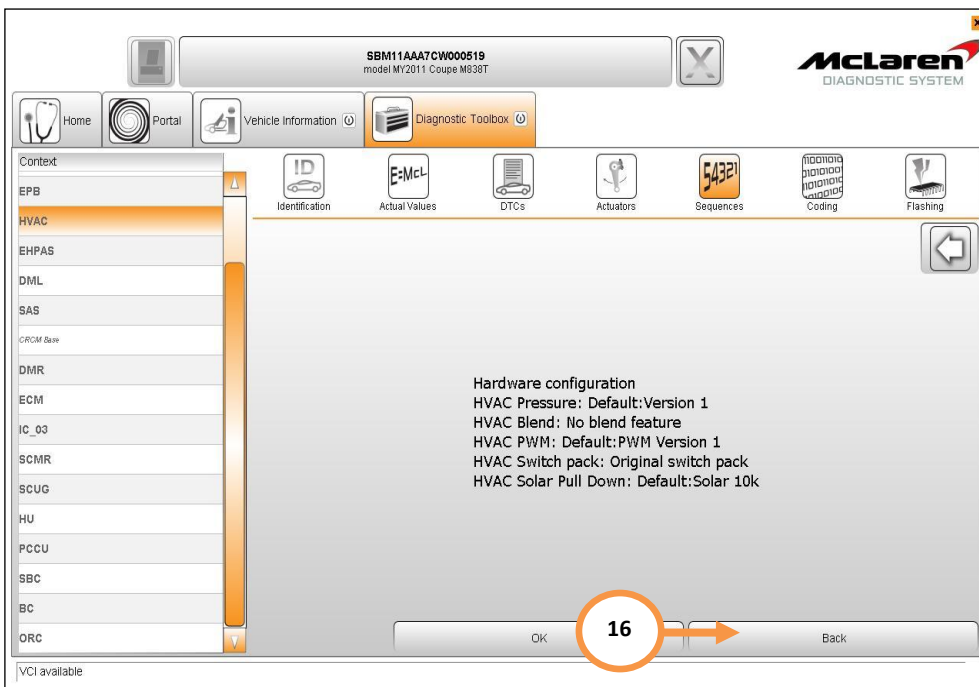

**Care point:** DTC B1A3A00 HVAC: Config Reset can be ignored.

## PCCU SOFTWARE UPDATE

**Care point:** During the downloading sequence the system may state preconditions or post conditions failed. These are erroneous messages and can be ignored. Only a programming failed message should be noted as a legitimate failure.

**Care Point:** Ensure vehicle lift is in the lowered position before reprogramming the PCCU. Suspension Displacement Sensor Calibration will fail to complete if the system is not fully lowered.

**Care point:** PCCU Degrade will appear after the update on the IC, this can be ignored.

**Care Point:** The vehicle must NOT be started until steps 32 to 35 have been completed.

**Care point:** The vehicle must be positioned on a two post ramp and in the fully lowered position.

27. Select PCCU (1), then Reprogramming (2), select the software level 11M0938CP.22 (3), then proceed to the software download by selecting the tick button (4), followed by the arrow button (5). Select 'YES' to initiate programming.

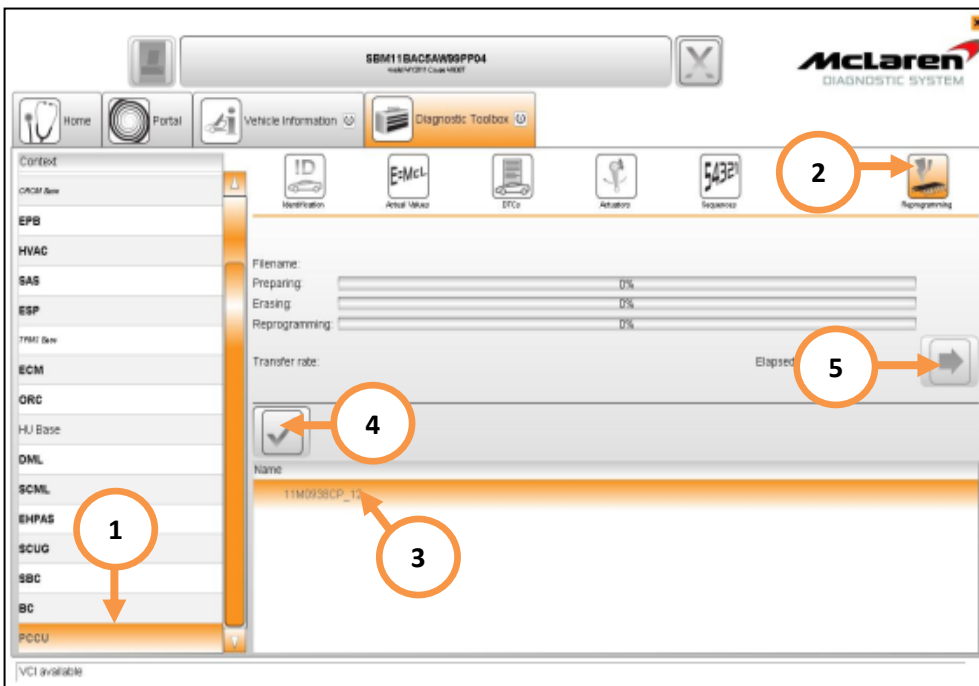

**Care Point:** HVAC DTC's U015500 CAN Missing IC and B1A3700 Kept Awake may not delete these can be ignored.

28. Cycle the ignition (on off on) and wait for 30 seconds. Place the vehicle into a sleep mode, and then establish the vehicle back into ignition state 5. Clear any DTC's before continuing on with the procedure.

29. Select PCCU (6), then Sequences (7), select Align Vehicle Configuration (8), followed by the arrow key (9).

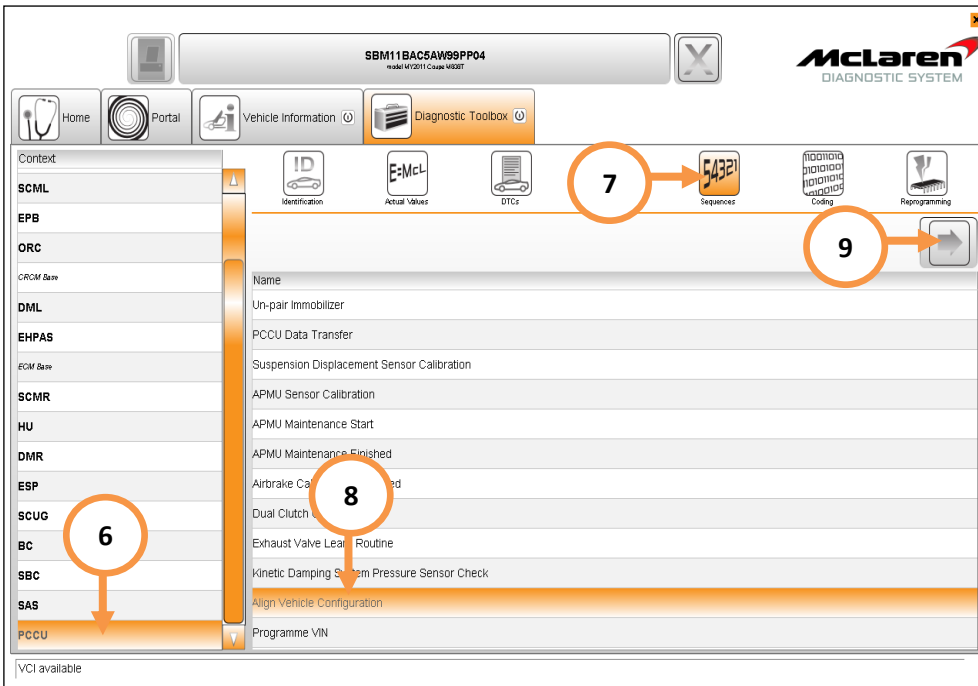

30. Select Programme VIN (10), followed by the arrow key (11).

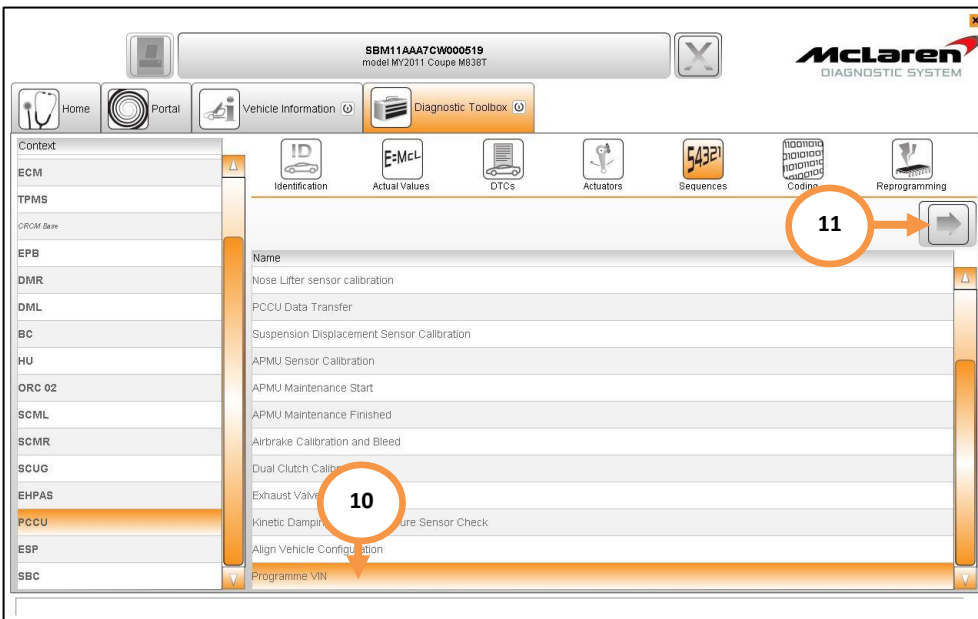

31. Cycle the ignition (on off on) and wait for 30 seconds.

**Care point:** The vehicle must be positioned on a two post ramp fully lowered whilst performing APMU sensor and Nose Lifter sensor calibrations.

**Care point:** Steps 32 to 35 only applies to vehicles that have PCCU software level 11M0938CP.20 or earlier installed.

32. Select APMU sensor calibration (12), followed by the arrow key (13).

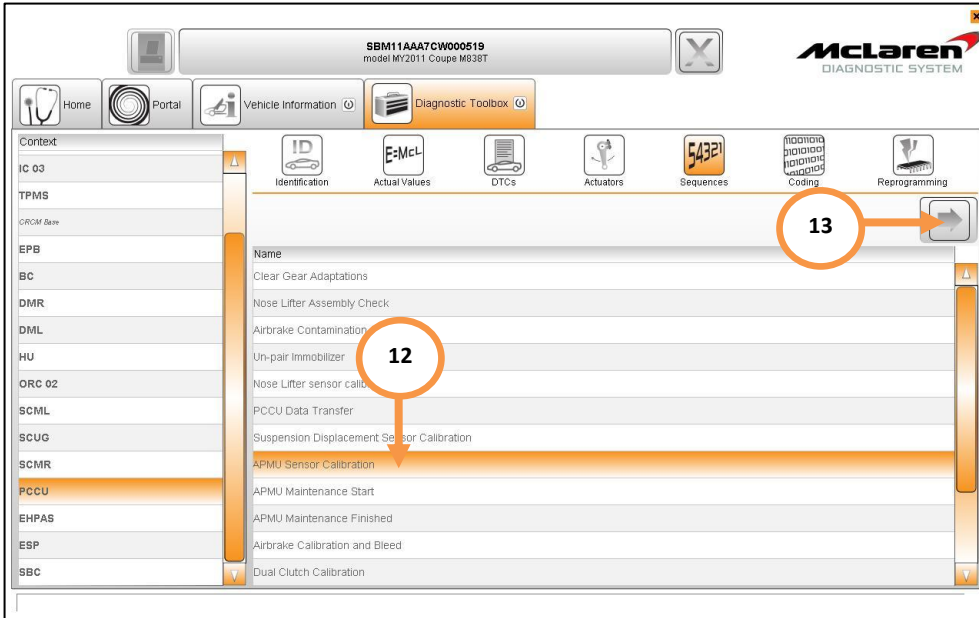

**Care point:** Step 33 is only required for vehicles fitted with Nose Lift.

33. Select Nose Lifter sensor calibration (14), followed by the arrow key (15).

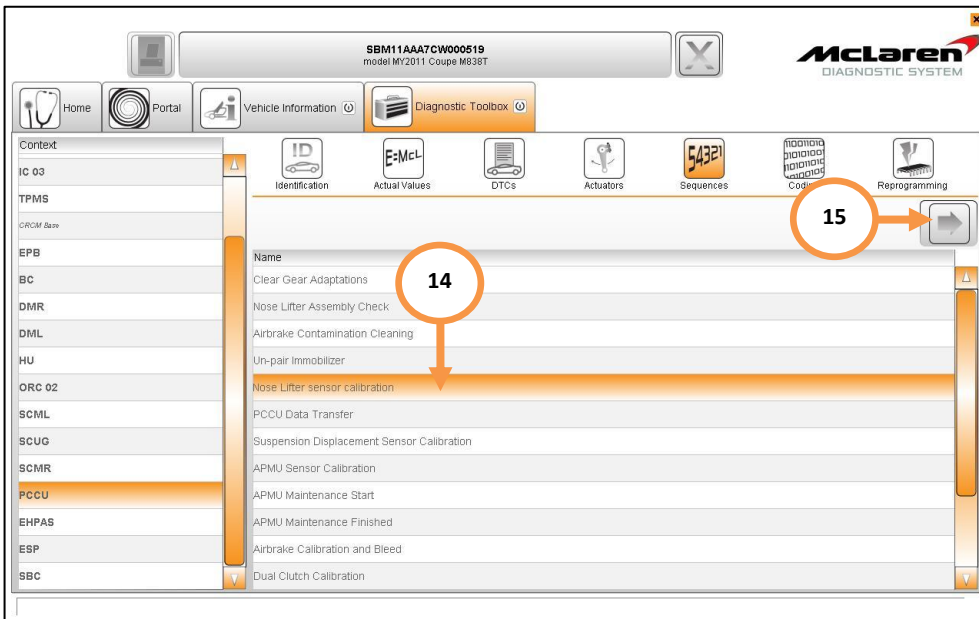

34. Select Suspension Displacement Sensor Calibration (16), followed by the arrow key (17) and then refer to Service Information Bulletin 11 B 007.

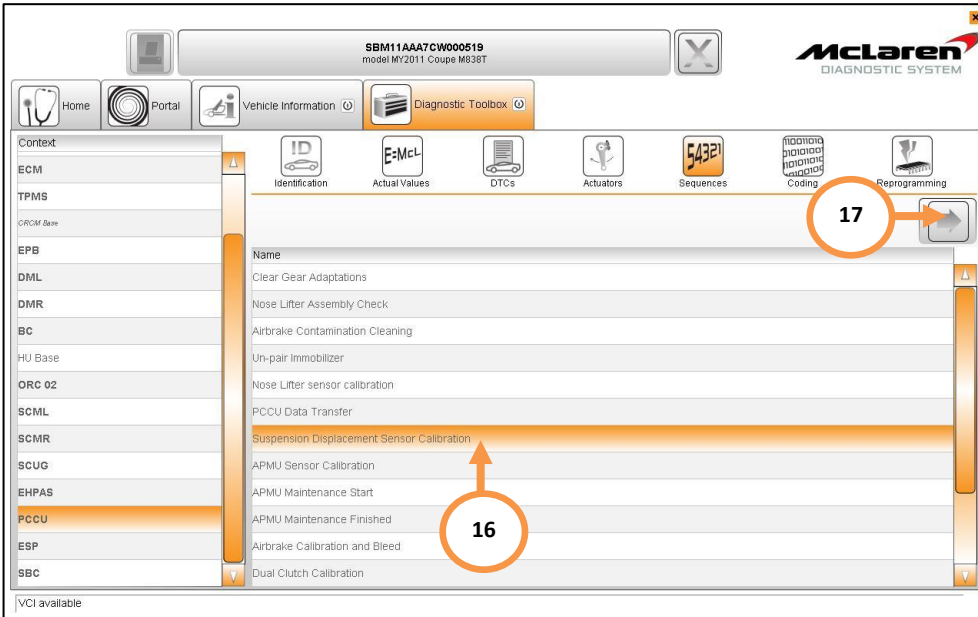

35. Select Programme VIN (18), followed by the arrow key (19).

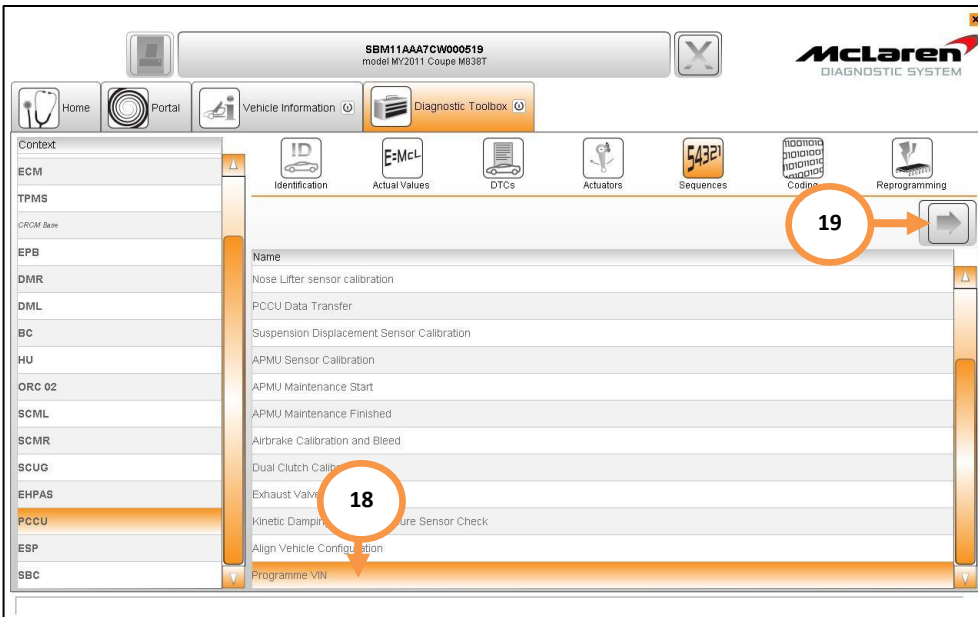



39. Select ECM (4), select Sequences (5), select ECM Calibration selection for DLD (6), followed by the arrow key (7).

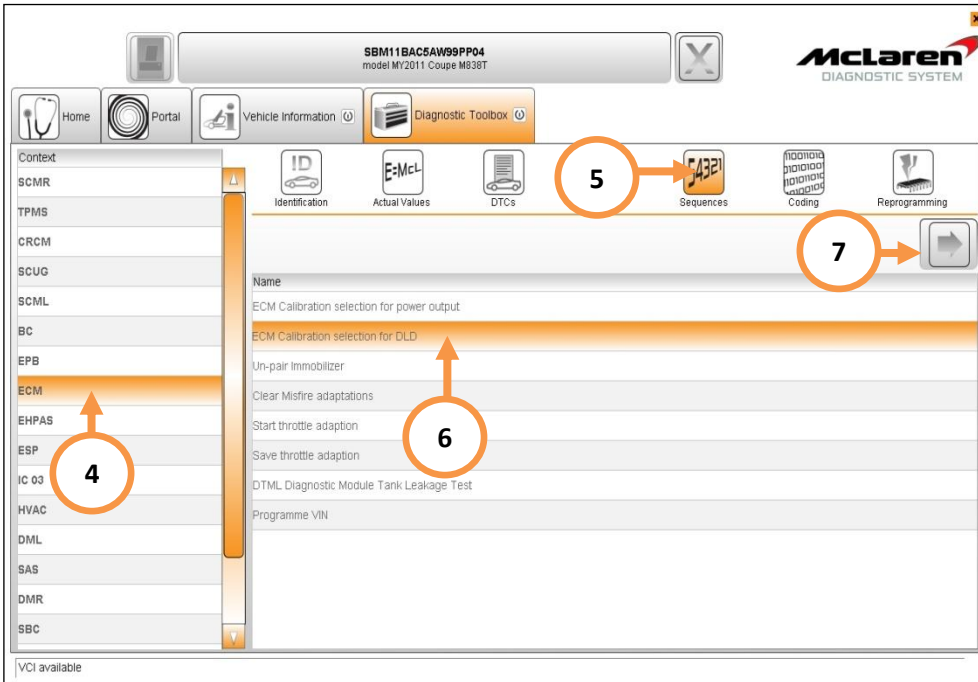

40. Ensure that the preconditions are met then select Ok (8).

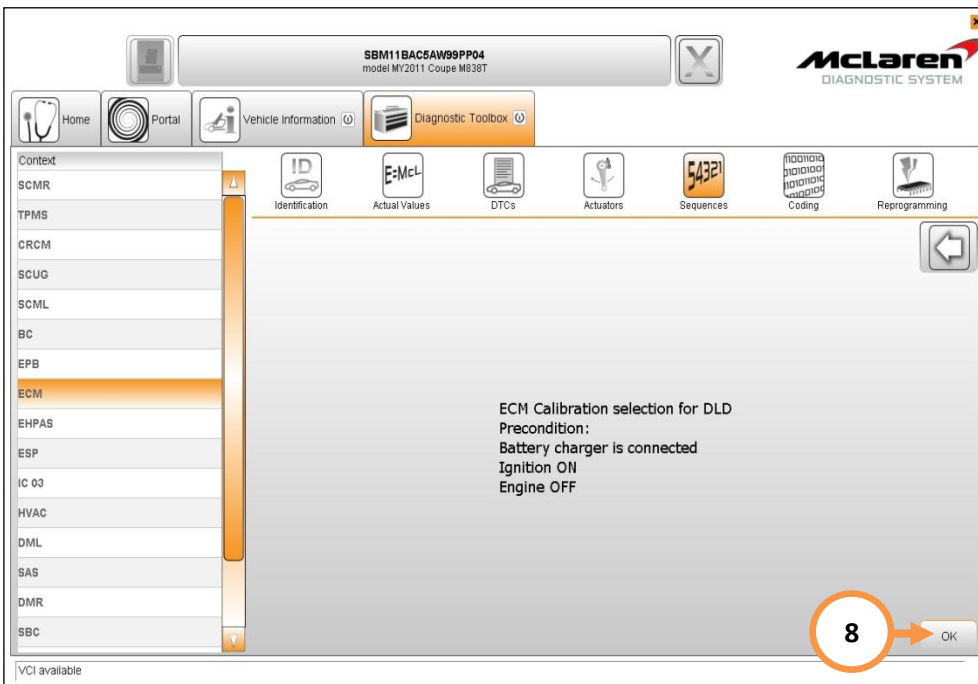

41. The following screen will be displayed, select No (9).

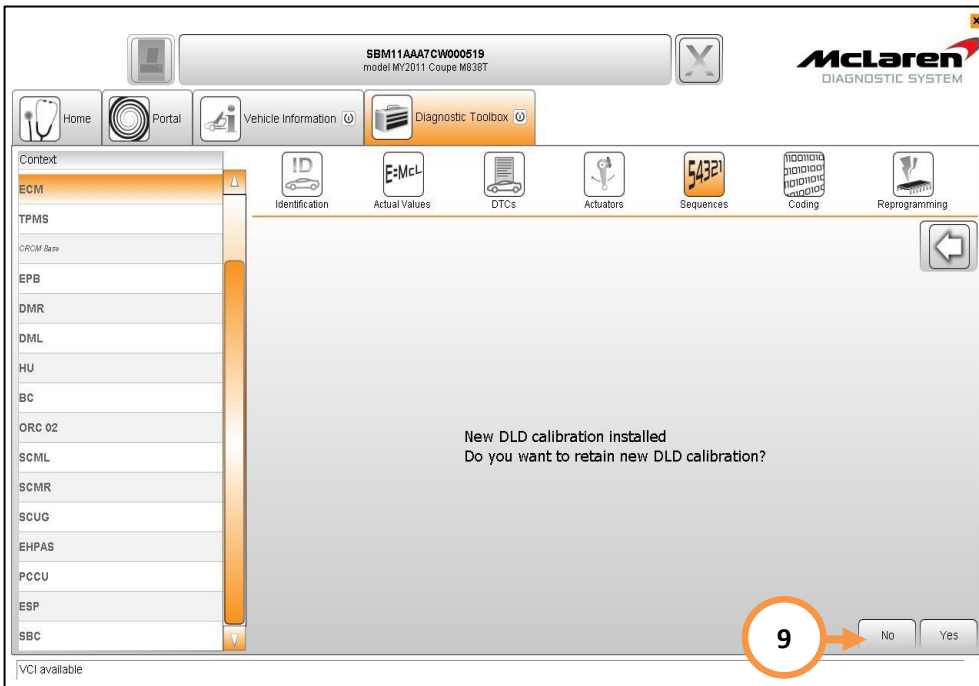

42. Operation successful will be displayed (10), rescan the car and proceed with reprogramming the ECM.

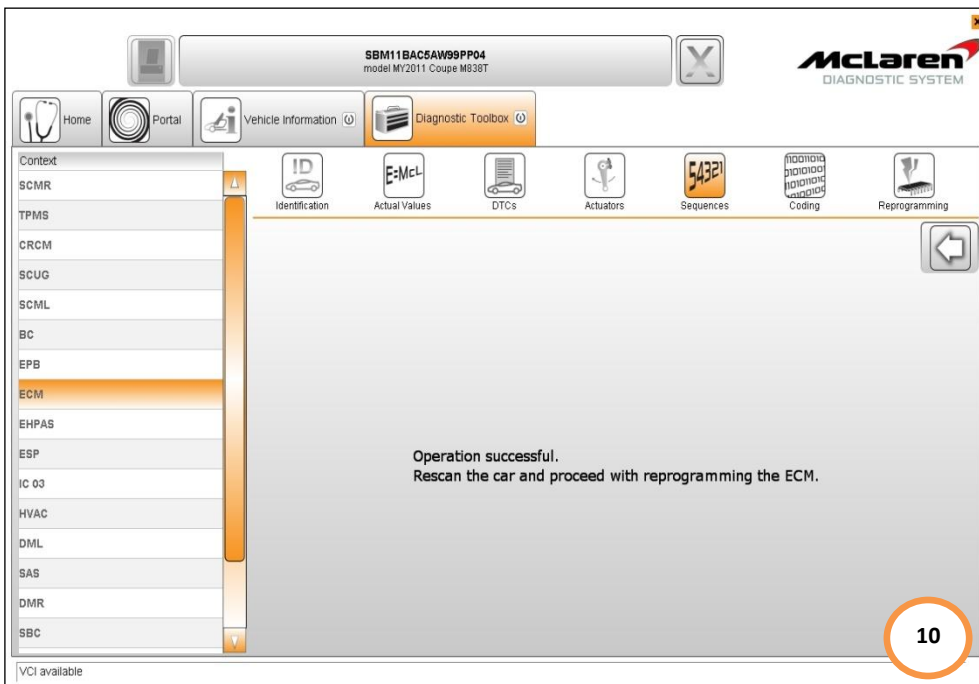

43. Select ECM (11), then Reprogramming (12), select the software variant applicable to your market (13), then proceed to the software download by selecting the tick (14) followed by the arrow button (15). Select 'Yes' to initiate programming.

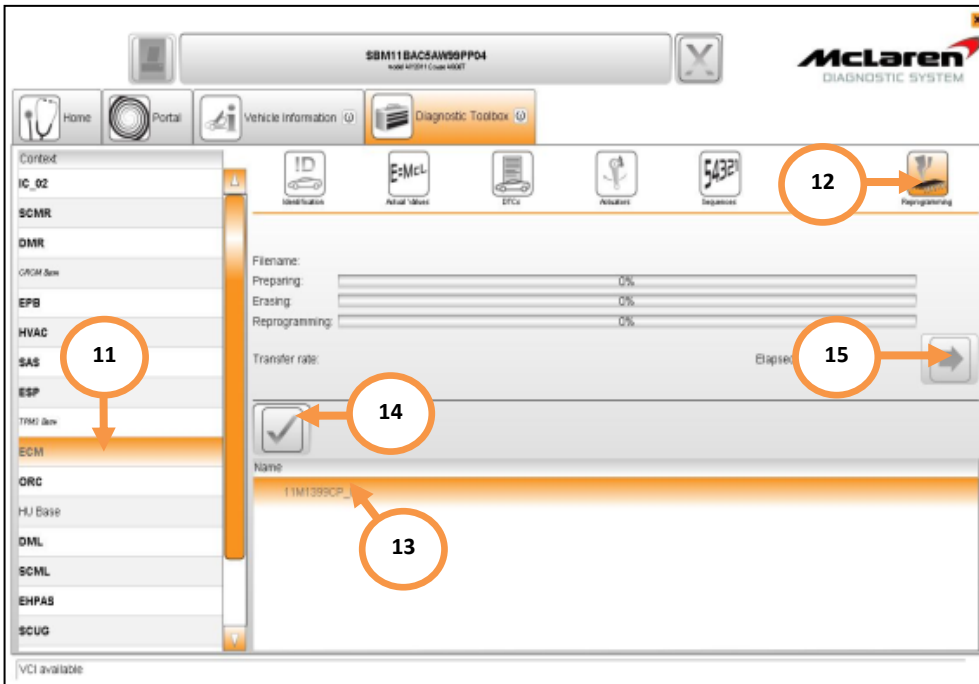

**Care point:** ECM DTC's must only be cleared in ignition state 5.

44. Cycle the ignition (on off on) and wait for 30 seconds. Place the vehicle into a sleep mode, and then establish the vehicle back into ignition state 5.

**Care Point:** HVAC DTC's U015500 CAN Missing IC and B1A3700 Kept Awake may not delete these can be ignored.

45. Select and highlight all items within the context fields (1) and perform a global clear of all DTC's (2).

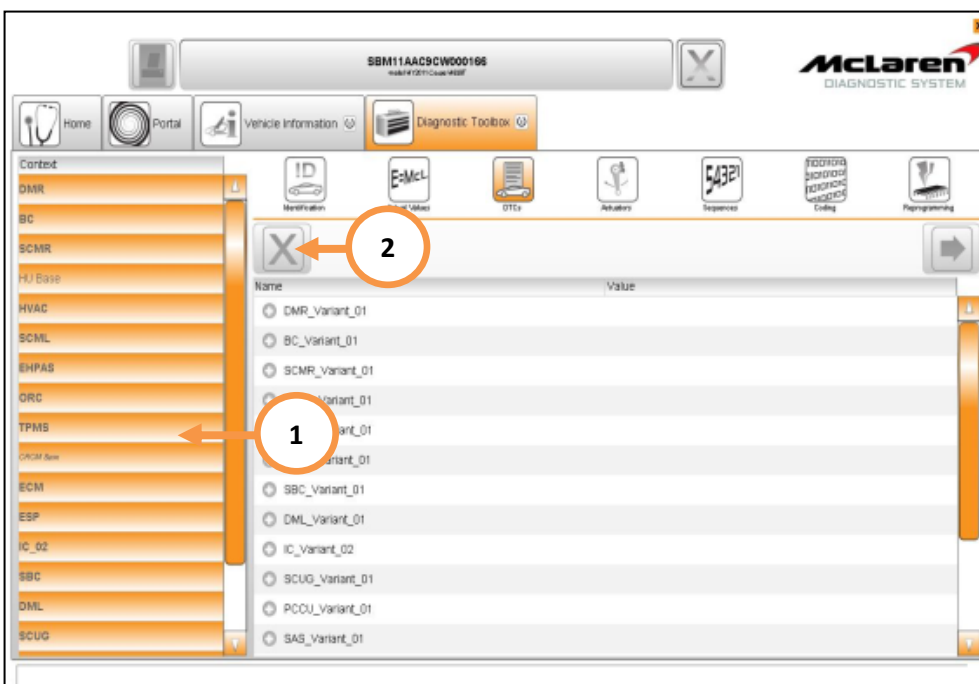

46. Press the stop/start button with the brake pedal depressed to start the engine and allow it to idle until fully warm.

**Care point:** The Air conditioning must be switched on and the engine coolant temperature must be above 80 degrees C before proceeding with the camshaft adaption procedure.

47. Select ECM (1), then Actual Values (2), select the following values as per the screenshot below (3), then select the play button to access the required data screen.

48. The inlet and exhaust camshaft values should be between 1 and 4, both values will fluctuate slightly. If all values are correct no further action is required proceed to step 50. If any values are incorrect proceed to step 49 to carry out the camshaft adaption.

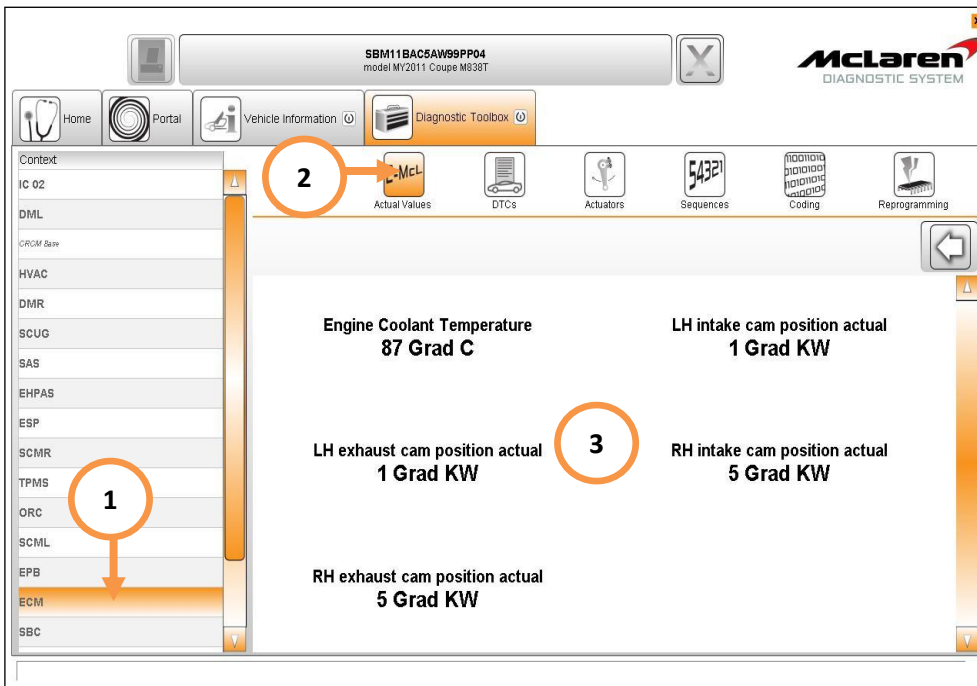

49. Switch the engine off, wait 30 seconds, restart the engine and recheck the values. Repeat this procedure until the target values are achieved.

**Care point:** The fuel level must be above ¼ before you proceed to the Diagnostic Module Tank Leakage Test (DMTL).

50. Select Sequences (1), then DMTL-Diagnostic Module Tank Leakage Test (2), followed by the arrow button to proceed (3).

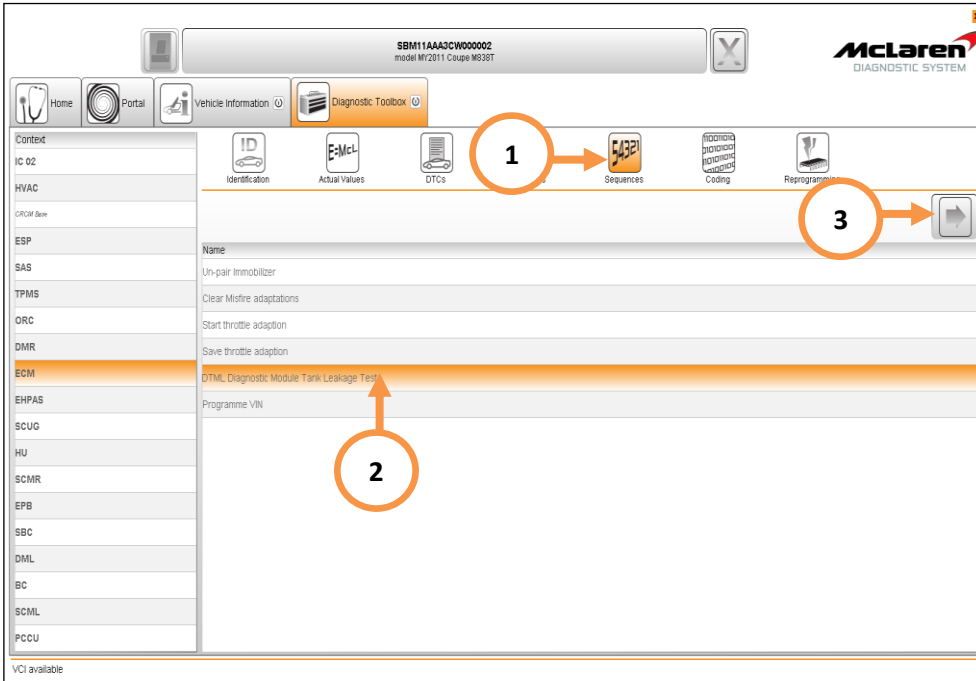

51. Follow the preconditions and run the engine for 60 seconds and then select Ok (4).

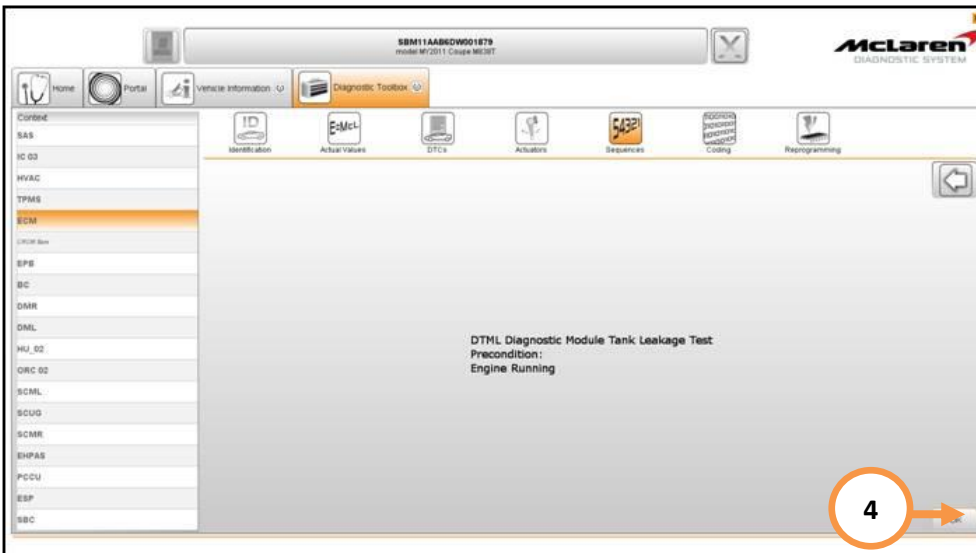

52. Follow the instructions on the next screen and then select Ok (5).

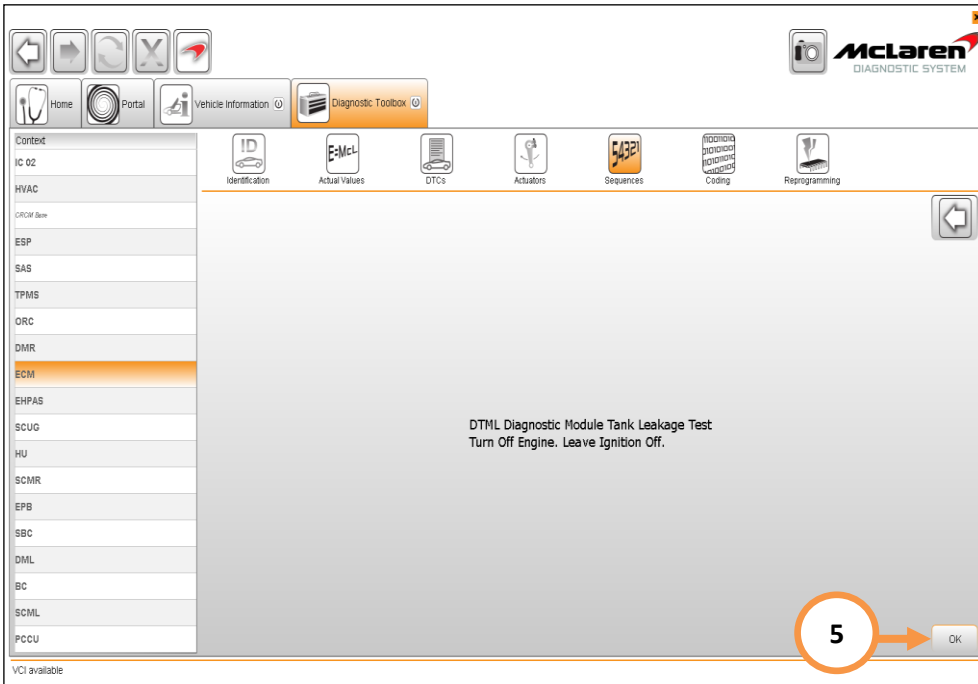

53. The DMTL test will now run and can take up to six minutes to complete the 20 thou and 40 thou leak test (6).

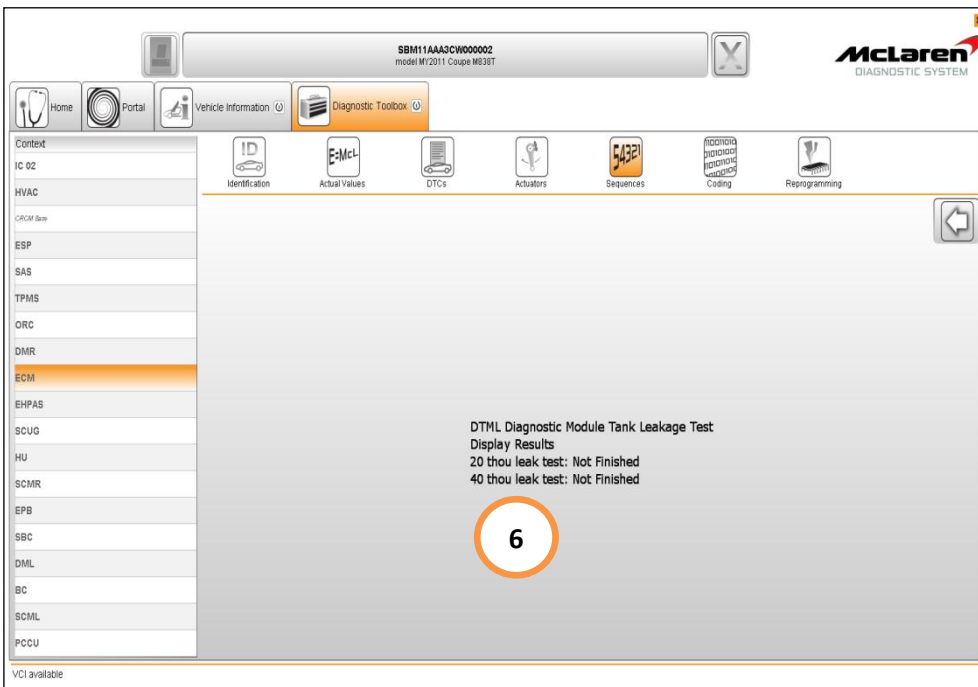

54. Then the 20 thou and 40 thou leak tests have completed the screen below will be displayed, then select Ok (7).

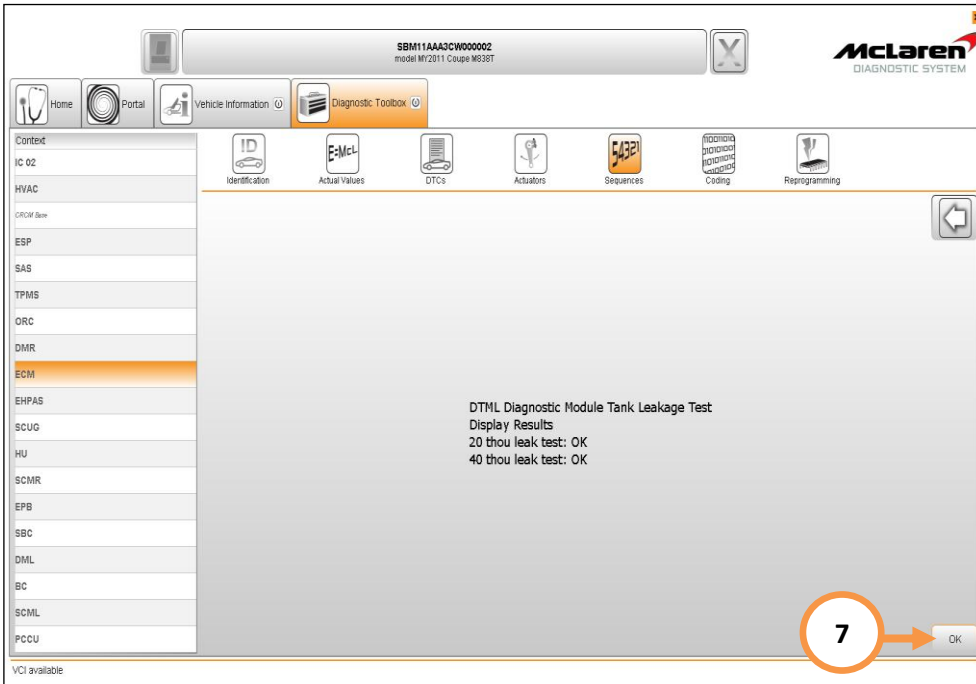

55. End the current MDS session to allow session feedback to be sent and stored at McLaren.

**Care point:** The VCI must be connected to the MDS with the USB cable to perform the next steps.

56. Start a New MDS session in the MDS Offline mode, refer to Service Information Bulletin 11 S 011 McLaren Diagnostic System (MDS) Offline and proceed to complete the remaining procedures.

57. Select ECM (1), then Sequences (2), then Clear Misfire adaptations (3), followed by the arrow button to proceed (4).



58. Select Actual Values (5), select the following values as per the screenshot below (6), then select the play button to access the required data screen.

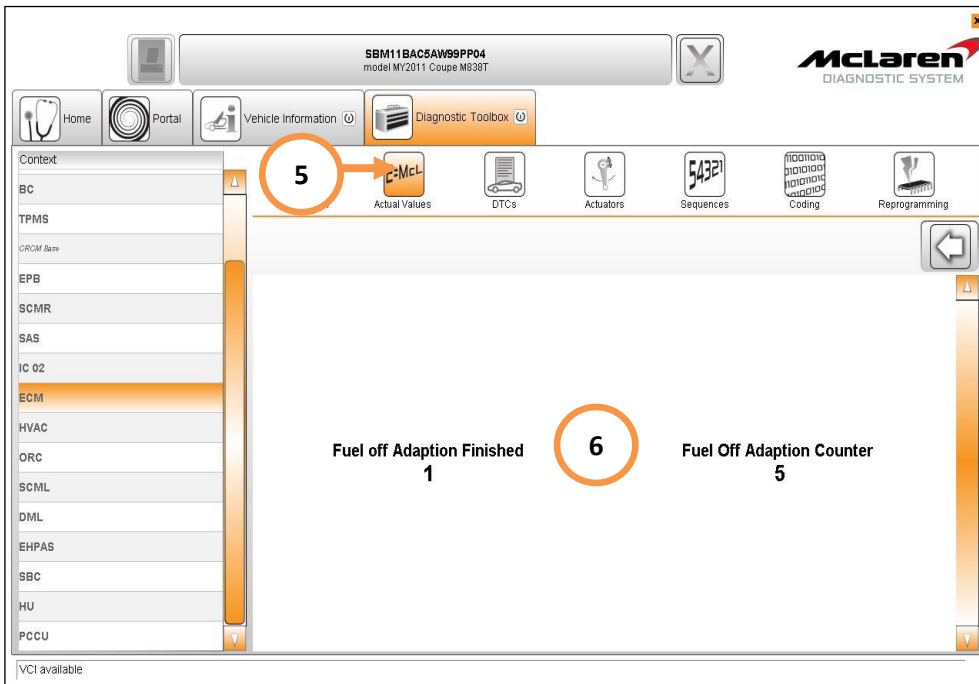

59. Misfire adaptations are performed whilst the car is driven with the gearbox set to manual mode and with the A/C off.

60. Perform eleven successive fuel cuts from above 4000rpm for a 5 second duration (a fuel cut off will occur when the accelerator pedal is fully released).

61. Once the Fuel off Adaption Counter reaches 11, the Fuel off Adaption Finished Counter will display 1; the misfire adaptation's have been learned. The Fuel off Adaption Counter will display Zero and then start to count again when further fuel cut offs occur, this is correct operation and no further action is required.

**Warranty information:** Total repair time also includes the time for carrying out Service Information Bulletin 11 B 007

Please contact your Regional Aftersales Manager should you have any questions relating to the information contained in this bulletin.

## WARRANTY INFORMATION

DESCRIPTION	RESOLUTION CODE	TOTAL REPAIR TIME
Software Platform Update to 12	M0M30110A33I4A07	1.50 hours

## PARTS INFORMATION

PART DESCRIPTION	PART NUMBER	QUANTITY	ORDER PROCESS
N/A	N/A	N/A	N/A

---