



Technical Service Bulletin

SUBJECT:			No: TSB-13-11-003
TIMING CHAIN OIL JET NOZZLE ELIMINATED – SERVICE MANUAL REVISION			DATE: March, 2013
			MODEL: See below
CIRCULATE TO:	<input type="checkbox"/> GENERAL MANAGER	<input checked="" type="checkbox"/> PARTS MANAGER	<input checked="" type="checkbox"/> TECHNICIAN
<input checked="" type="checkbox"/> SERVICE ADVISOR	<input checked="" type="checkbox"/> SERVICE MANAGER	<input type="checkbox"/> WARRANTY PROCESSOR	<input type="checkbox"/> SALES MANAGER

PURPOSE

The timing chain oil jet nozzle has been eliminated in engine production. Because of this, the shape and position of the timing chain oiling hole has changed.

!! IMPORTANT !!

Do not eliminate the oil jet from engine blocks with the original oil jet hole shape and position.

AFFECTED VEHICLES

- 2010 Lancer built from January 10, 2010
- 2010 Lancer Sportback built from January 10, 2010
- 2010 Lancer Evolution built from January 10, 2010
- 2010 Outlander equipped with 2.4L engine built from January 10, 2010

AFFECTED SERVICE MANUALS

- 2010 Lancer Service Manual Group
 - 11B Engine Overhaul <2.0L Engine:Non-turbo>: Timing Chain > Removal and Installation
 - 11D Engine Overhaul <2.0L Engine:Turbo>: Timing Chain > Removal and Installation
 - 11F Engine Overhaul <2.4L Engine>: Timing Chain > Removal and Installation
- 2010 Lancer Sportback Service Manual Group
 - 11B Engine Overhaul <2.0L Engine>: Timing Chain > Removal and Installation
 - 11D Engine Overhaul <2.4L Engine>
- 2010 Lancer Evolution Service Manual Group
 - 11B Engine Overhaul: Timing Chain > Removal and Installation
- 2010 Outlander Service Manual Group
 - 11B Engine Overhaul <2.4L Engine>: Timing Chain > Removal and Installation

Continued

Copyright 2013, Mitsubishi Motors North America, Inc.

(3986)

The information contained in this bulletin is subject to change. For the latest version of this document, go to the Mitsubishi Dealer Link, MEDIC, or the Mitsubishi Service Information website (www.mitsubishitechinfo.com).

2010 Lancer Service Manual Group

11B Engine Overhaul <2.0L Engine:Non-turbo>: Timing Chain > Removal and Installation

11D Engine Overhaul <2.0L Engine:Turbo>: Timing Chain > Removal and Installation

11F Engine Overhaul <2.4L Engine>: Timing Chain > Removal and Installation

2010 Lancer Sportback Service Manual Group

11B Engine Overhaul <2.0L Engine>: Timing Chain > Removal and Installation

11D Engine Overhaul <2.4L Engine>

2010 Lancer Evolution Service Manual Group

11B Engine Overhaul: Timing Chain > Removal and Installation

2010 Outlander Service Manual Group

11B Engine Overhaul <2.4L Engine>: Timing Chain > Removal and Installation

TIMING CHAIN

REMOVAL AND INSTALLATION

M1113026600636

Apply engine oil to all moving parts before installation.

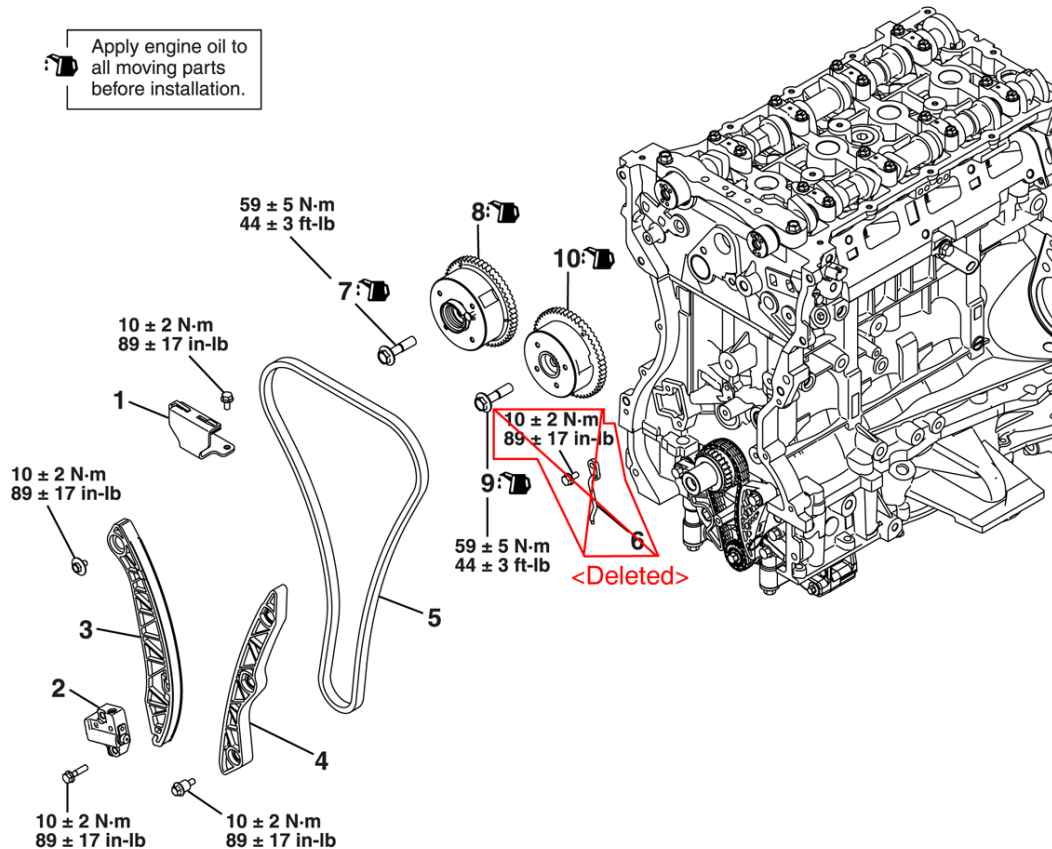

AK502933AD

Removal steps

- <<A>> >>D<<
1. Chain upper guide
 2. Timing chain tensioner
 3. Tensioner lever
 4. Timing chain guide
 - >>C<< 5. Timing chain

<Deleted> Removal steps (Continued)

- <> >>B<<
- ~~6 Oil jet~~
- <<C>> >>A<<
7. Exhaust V.V.T. sprocket bolt
 8. Exhaust V.V.T. sprocket assembly
 9. Intake V.V.T. sprocket bolt
 10. Intake V.V.T. sprocket assembly

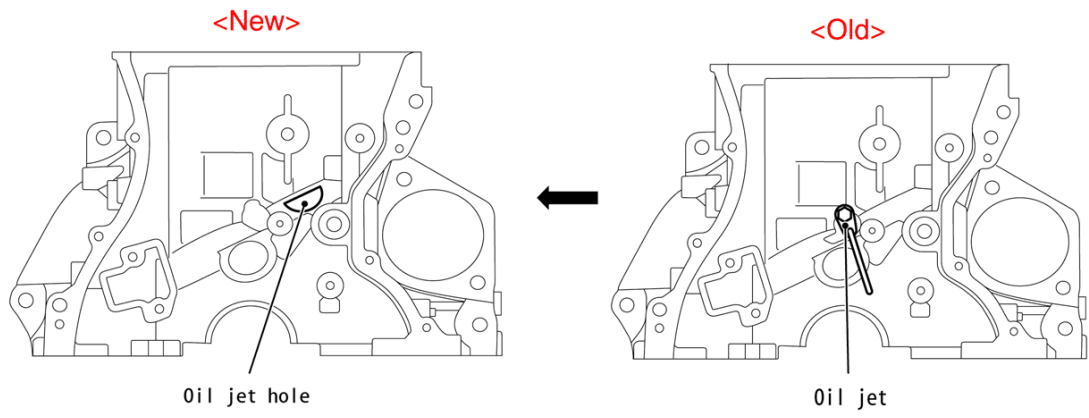

ACD01093