



Technical Service Bulletin

SUBJECT:		No:	TSB-13-00-004
NEW MODEL FEATURES & SERVICE INFORMATION - 2013 OUTLANDER SPORT/RVR (REVISED)		DATE:	February, 2013
		MODEL:	2013 Outlander Sport
CIRCULATE TO:	<input type="checkbox"/> GENERAL MANAGER	<input checked="" type="checkbox"/> PARTS MANAGER	<input checked="" type="checkbox"/> TECHNICIAN
<input checked="" type="checkbox"/> SERVICE ADVISOR	<input checked="" type="checkbox"/> SERVICE MANAGER	<input checked="" type="checkbox"/> WARRANTY PROCESSOR	<input checked="" type="checkbox"/> SALES MANAGER

This bulletin supercedes TSB-12-00-013, issued July, 2012 to add information regarding LE models. Changes are italicized and indicated by ◀.

PURPOSE



This TSB highlights important features and service information for the **2013 Outlander Sport** (U.S. Models only). Review the details in this bulletin to familiarize yourself with new service information, features and options. Refer to the 2013 Outlander Sport/RVR service manual on MEDIC or CD (*p/n MSCD-017B-2013*) and the owner's manual for details on these and other features.

Built in the U.S.

Left hand drive versions of the 2013 Outlander Sport are built by the manufacturing division of Mitsubishi Motors North America in Normal, Illinois, which also handles left hand drive distribution to other regions of the world, including some South American countries, Russia and some Middle Eastern countries.

AFFECTED VEHICLES

2013 Outlander Sport

U.S. MODEL LINEUP

Model	Engine	Transmission
ES	4B11 - 2.0L DOHC MIVEC 16V 4 cyl.	5 M/T: (FWD) CVT: (FWD or 4WD)
SE	4B11 - 2.0L DOHC MIVEC 16V 4 cyl.	CVT: (FWD or 4WD)
<i>LE</i>	<i>4B11 - 2.0L DOHC MIVEC 16V 4 cyl. (with balance shaft/oil pump module)</i>	<i>CVT: (FWD or 4WD)</i> ◀

SERVICE INFORMATION

See TSB-13-00-003 for Technical Specifications. ◀

NEW FEATURE HIGHLIGHTS

ENGINE

4G11 2.0L engine with balancer shaft and oil pump module adopted

Air filter element changed to frameless type.

COMMENTS

2013 Outlander Sport LE models ◀

All 2013 Outlander Sport

Continued
Copyright 2013, Mitsubishi Motors North America, Inc.

(3969)

The information contained in this bulletin is subject to change. For the latest version of this document, go to the Mitsubishi Dealer Link, MEDIC, or the Mitsubishi Service Information website (www.mitsubishi-technicalinfo.com).

FUEL

Quarter turn style gas cap adopted.

All 2013 Outlander Sport

TRANSMISSION

ES 4WD model available.

2013 Outlander Sport ES

Improved CVT calibration for better acceleration and responsiveness.

All 2013 Outlander Sport models

WHEEL & TIRE

18" Alloy wheels standard on all trim levels.
Chrome finish for LE models.

All 2013 Outlander Sport models

**BRAKES**

Parking brake mechanism changed to ball and ramp type to actuate caliper and apply rear service brake.

All 2013 Outlander Sport Models

EXTERIOR

New front and rear fascia design with two tone appearance.

All 2013 Outlander Sport models

Side air dam color changed to black.

All 2013 Outlander Sport models

Blackout center front bumper treatment

2013 Outlander Sport LE



Front and rear wheel lip arch trim

2013 Outlander Sport LE



Black door mirrors

2013 Outlander Sport LE



Black roof rails

2013 Outlander Sport LE

**INTERIOR**

SiriusXM satellite radio, heated front seats and chrome beltline molding standard.

2013 Outlander Sport SE

Center dome lamp and rear armrest w/cup holder standard.

All 2013 Outlander Sport models

New interior fabrics.

2013 Outlander Sport ES & SE

New 4WD mode selector button.

2013 Outlander Sport w/4WD

New chrome door trim accent.

All 2013 Outlander Sport models

Chrome bezel for OSS ignition button

2013 Outlander Sport LE

Leather parking brake lever handle

2013 Outlander Sport LE



Aluminum accelerator and brake pedals

2013 Outlander Sport LE



Power driver's seat (fabric)

2013 Outlander Sport LE



CHASSIS ELECTRICAL

Steering column lock eliminated.

All 2013 Outlander Sport Models.
Anti-theft performance is not affected due to ignition immobilizer.

Battery changed from JIS specification to SAE.
Group 35-118, 530 CCA

All 2013 Outlander Sport models

ENGINE

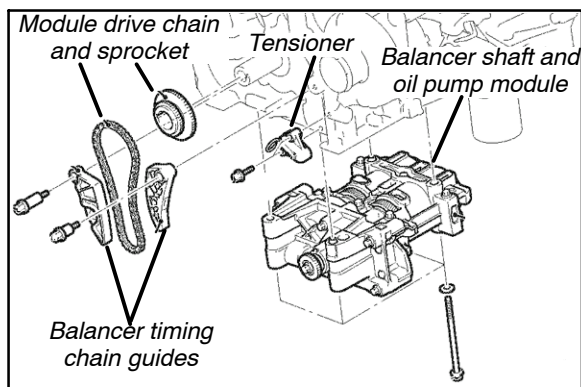

2013 Outlander Sport LE is powered by a 2.0L 4B11 4 cyl. engine with an added balancer shaft and oil pump module to smooth out engine vibration. The chain-driven module is attached to the engine block below the crankshaft using 4 bolts. An enlarged oil pan is used to provide sufficient space and oil volume for the module. Engine oil capacity is increased to 4.6 qts/4.35 ltr. (without filter).

Refer to TSB-13-11-002 for additional information and service procedures.

FUEL

Quarter turn style gas cap adopted



Easier opening/closing effort for IQS improvement.

BRAKES

Parking brake mechanism changed to actuate caliper and apply service brake pads.

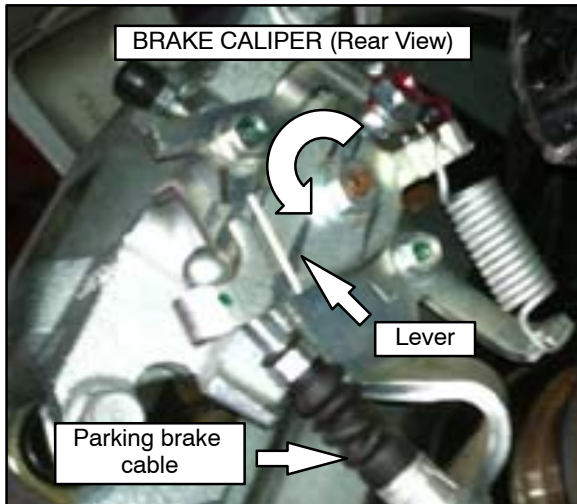

Parking brake cable connects to a lever on the caliper. The mechanism rotates to apply the parking brake.

EXTERIOR

New front and rear fascia design with two tone appearance. Side air dam color changed to black



Provides more sophisticated appearance.
Cleaner appearance due to elimination of character lines.
Simplified paint line makes the rear view appear wider.



2013 Outlander Sport LE includes a blackout treatment for the center of the front fascia, black roof rails, black mirrors, black wheel arch lip trim and 18" alloy wheels with a chrome finish.



INTERIOR

New 4WD mode selector button



Mode selector button replaces rotary knob.

Press the button to toggle through 2WD/4WD modes:

- 2WD
↓
- 4WD
↓
- 4WD Lock
↓
- 2WD

SPECIAL TOOLS

The following new special tools are listed for 2013 models:

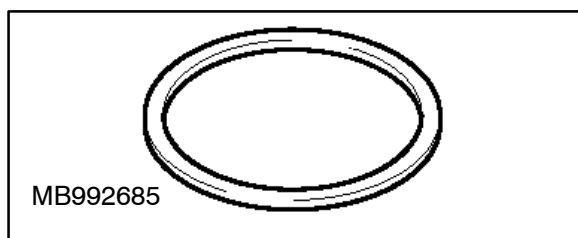

Group 34 – Rear Suspension

MB992685 – Spacer base

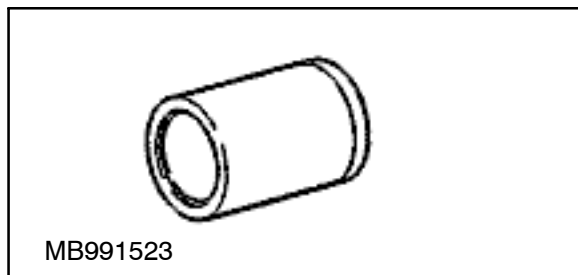

Group 34 – Rear Suspension

MB991523 – Arm bushing remover and installer

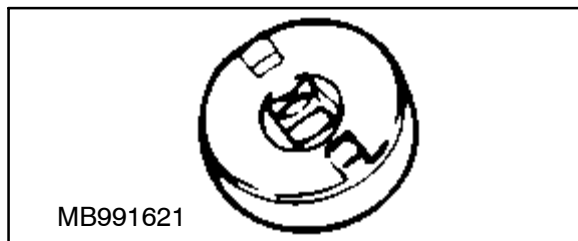

Group 35 – Brakes

MB991621 – Piston Driver

Superseded to MB991898-01 or general service tool

FACTORY OPTION PACKAGES (U.S. Models)

SE PREMIUM PACKAGE – 2013 Outlander Sport SE only

- Panoramic Glass Roof with LED Lighting and Sunshade
- Black Roof rails
- Auto Dimming Electro Chromic Rear View Mirror with Rear Camera Display
- 710-Watt (max) Rockford-Fosgate Premium Audio System with standard SIRIUSXM Satellite Radio (with 3 Month prepaid Subscription) and 6CD/MP3 In-dash Head Unit.
- Rear Camera System

LE PREMIUM PACKAGE – 2013 Outlander Sport LE only

- *Panoramic Glass Roof with LED Lighting and Sunshade*
- *Auto Dimming Electro Chromic Rear View Mirror with Rear Camera Display*
- *Rear Camera System*
- *710-Watt (max) Rockford-Fosgate Premium Audio System with standard SIRIUSXM Satellite Radio (with 3 Month prepaid Subscription) and 6CD/MP3 In-dash Head Unit.*

EXTERIOR SPORT PACKAGE – 2013 Outlander Sport

- Large Rear Spoiler
- Front Corner Extensions
- Front Undercover
- Rear Undercover
- Aluminum Alloy Fuel Door
- LED Daytime Running Lights

INTERIOR PACKAGE – 2013 Outlander Sport (must be equipped with CVT)

- Piano Black Shift Panel and Audio Surround Overlays
- Aluminum Alloy and Leather Combination Shift Knob.

LED ILLUMINATION PACKAGE – 2013 Outlander Sport

- LED Interior Lamps
- Blue LED Floor and Tailgate Illumination

PROTECTION PACKAGE – 2013 Outlander Sport

- Tailgate Protector
- *Rear Bumper Guard*
- Mudguards
- *Aluminum Scuff Plates*

LE PROTECTION PACKAGE – 2013 Outlander Sport LE

- *Aluminum Scuff Plates*
- *Tailgate Protector*
- *Rear Bumper Guard*

PARK ASSIST PACKAGE – 2013 Outlander Sport

- *Front and rear park assist sensors*

CARGO PACKAGE – 2013 Outlander Sport

- Reversible Cargo Mat
- Cargo Net
- Cargo Shelf Cover

ALL WEATHER PACKAGE – 2013 Outlander Sport

- Remote Engine Start
- All Weather Floor Mats (4)
- Mudguards

NAVIGATION – 2013 Outlander Sport

- 40 GB HDD Navigation with Music Server and Real-Time Traffic (RDS)

NAVIGATION W/REARVIEW CAMERA – 2013 Outlander Sport SE only

- 40 GB HDD Navigation with Music Server and Real-Time Traffic (RDS)
- Rearview Camera System

PORT OR DEALER INSTALLED OPTIONS (U.S. Models)

- Remote Engine Start
- All Weather Floor Mats (4)
- *Premium Black Leather Seating Surfaces (SE)*
- *Premium two-tone dove gray black leather seating surfaces (LE only)*
- In-dash 6-disc CD/MP# compatible changer (replaces audio head unit)
- Park Assist Sensors (Front and/or Rear)
- Roof Rack Crossbars
- Body Side Moldings
- Fog Lights with Chrome Bezel
- Side Wind Deflectors
- Wheel Locks

WARRANTY

U.S. and Puerto Rico	Canada
● Basic – 5 years or 60,000 miles	● Basic – 5 years or 100,000 km
● Powertrain – 10 years or 100,000 miles (original retail purchaser only). 5 years or 60,000 miles to subsequent owners.	● Powertrain – 10 years or 160,000 km
● Rust Perforation – 7 years or 100,000 miles	● Rust Perforation – 5 years with unlimited km
● Adjustments – 1 year or 12,000 miles	● Adjustments – 1 year or 20,000 km
● Roadside Assistance – 5 years / unlimited mi.	● Roadside Assistance – 5 years/unlimited km.